

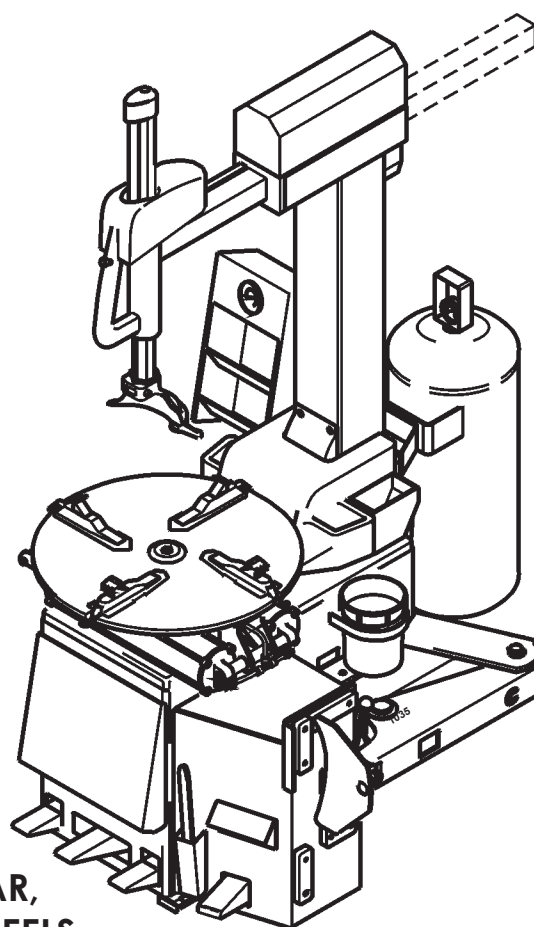

ACCU 5602



**ELECTRIC-AIR TIRE CHANGER FOR CAR,
LIGHT TRUCK AND MOTORCYCLE WHEELS**

OPERATOR'S MANUAL
SPARE PARTS EXPLODED DRAWINGS

LIMITED WARRANTY

Accu Industries, Inc. ("Seller") provides a one year limited warranty on parts and labor on all goods manufactured by it, including this product. The sole and exclusive warranty which Seller makes with respect to this product and all parts and accessories thereto which are sold by Seller is a warranty limited to defects in material or workmanship for a period of one year from the date of original purchase by Buyer from Seller. For purposes of the commencement of the one-year warranty period, the term "Buyer" shall not include wholesalers, retailers or others who buy this product for resale to end user. However, in no event shall the warranty extend beyond two years from the original sale (invoice data) of this product by Seller to anyone.

This warranty applies only to this product and any parts or accessories which are attached to or shipped by the Seller to Buyer with it. This warranty does not apply to equipment parts or accessories damaged by improper and/or negligent operation or maintenance, modification, misuse, abuse, neglect, abrasion or corrosion, nor to any equipment, parts, or accessories which were not manufactured by Seller. This warranty does not apply to any "wear out" components of this product.

"Wear out" shall mean those components or parts which are consumed, used or experienced wear during the ordinary operation of this product. This warranty shall be void if the equipment, parts, or accessories are dismantled, tampered with or repairs are attempted or made by anyone other than Seller or its authorized agent.

THE EXPRESS WARRANTY SET FORTH HEREIN IS IN LIEU OF ALL OTHER WARRANTIES, EXPRESS OR IMPLIED, INCLUDING, BUT NOT LIMITED TO, ANY WARRANTIES OF MERCHANTABILITY OR FITNESS FOR A PARTICULAR PURPOSE, AND ALL SUCH WARRANTIES ARE HEREBY DISCLAIMED AND EXCLUDED BY SELLER. THERE ARE NO WARRANTIES WHICH EXTEND BEYOND THE DESCRIPTION ON THE FACE HEREOF.

No equipment or parts or accessories shall be shipped by Buyer to Seller without first notifying Seller and specifying the nature of the claimed defect. Any such equipment, parts, or accessories claimed to be defective must be returned, freight prepaid, to Accu Industries, Inc., 11126 Air Park Road, Ashland, Virginia 23005. If inspection by Seller shows the equipment, part, or accessory to be defective, Seller will repair or replace the same and if the Seller elects to repair or replace the same, Seller will return the same to Buyer, freight prepaid.

Buyer 's sole and exclusive remedy against Seller under this Limited Warranty shall be limited to repair or replacement, at Seller 's option, of defective equipment, parts, or accessories covered here under. Seller 's liability shall in no event exceed that expressly set forth herein, irrespective of the basis for any other claim, including but not limited to claim for breach of contract, breach of warranty, negligence, strict liability or tort, and under no circumstance shall be liable for incidental or consequential damages.

Seller shall not be liable for any losses, damages, or expenses, whether direct or indirect, incidental or consequential, caused by or resulting from the use of defective or non conforming equipment, parts, or accessories, or from delays in delivery. Buyer and Seller agree that the venue for any claim or breach or warranty shall be exclusively in the Circuit or General District courts of Hanover County, Virginia.

TABLE OF CONTENTS

1.0 INTRODUCTION 4

1.1 NOMENCLATURE 4

1.2 SPECIFICATIONS 4

1.3 DIMENSION OF THE MACHINE 4

1.4 STANDARD ACCESSORIES 5

1.5 OPTIONAL ACCESSORIES 5

1.6 GENERAL PRECAUTIONS 6

2.0 INSTALLATION 6

2.1 ELECTRIC INSTALLATION 7

2.2 AIR INSTALLATION 7

3.0 CONTROLS 8

4.0 MOUNTING AND DEMOUNTING PRECAUTIONS 9

4.1 DEMOUNTING TUBELESS TIRES 9

4.2 MOUNTING TUBELESS TIRES 10

4.3 INFLATION OF TUBELESS TIRES 11

5.0 DEMOUNTING TUBE-TYPE TIRES 12

5.1 MOUNTING TUBE-TYPE TIRES 12

5.2 INFLATING TUBE-TYPE TIRES 13

6.0 MOUNTING AND DEMOUNTING MOTORCYCLE TIRES 13

7.0 MAINTENANCE 14

8.0 SPARE PARTS 15

1.0 INTRODUCTION

Congratulations on purchasing the ACCU-TURN 5602 pneumatic-electric tire changer.

This tire changer is designed for ease of operation, safe handling of rims, reliability and speed.

This combination of features means more profit and added versatility for your shop, enabling you to work with aluminum or magnesium alloy wheels without damaging customer's rims.

With a minimum of maintenance and care your ACCU-TURN 5602 will provide many years of trouble-free operation.

Please read this manual thoroughly before operating the unit. Instructions on use, maintenance and operational requirements of the machine are covered in this manual.

1.1 NOMENCLATURE

Before installing and using the ACCU-TURN 5602 it is suggested that you become familiar with the nomenclature of the machine's components (Fig.1.1-1).

- 1. Vertical slide
- 2. Horizontal slide
- 3. Lock button
- 4. Handle
- 5. Mount/demount tool or head
- 6. Tilting tower or column
- 7. Turntable
- 8. Jaw or clamp
- 9. Bead breaker arm
- 10. Bead breaker blade
- 11. Bead breaker pads
- 12. Lube pail
- 13. Foot pedal controls
- 14. Bead seater/inflator pedal

1.2 SPECIFICATIONS

Electric-pneumatic tire changer for car, light commercial vehicle and motorcycle tires designed for one-piece rims.

- Weight.....lbs 607 (276 Kg)
- Air pressure required.....psi 110-170 (8-12 bar)
- Bead breaker tool force.....lbs 3300 (kN 15)
- Electric specifications.....115V, 1 ph, 60 Hz.
- Motor.....Hp 1 (0.75 kW)
- Max. torque.....740 ft·lbs (Nm 1000)
- Max. wheel diameter.....39" (1000 mm)
- Max. tyre width.....15" (381 mm)
- Max. rim width.....13" (330 mm)
- Rim diameter outside locking.....10"-24"
- Rim diameter inside locking.....12"-24"
- Motorcycle rim locking with adaptors.....8"-23"

1.3 DIMENSIONS OF THE MACHINE (Fig. 1.3-1)

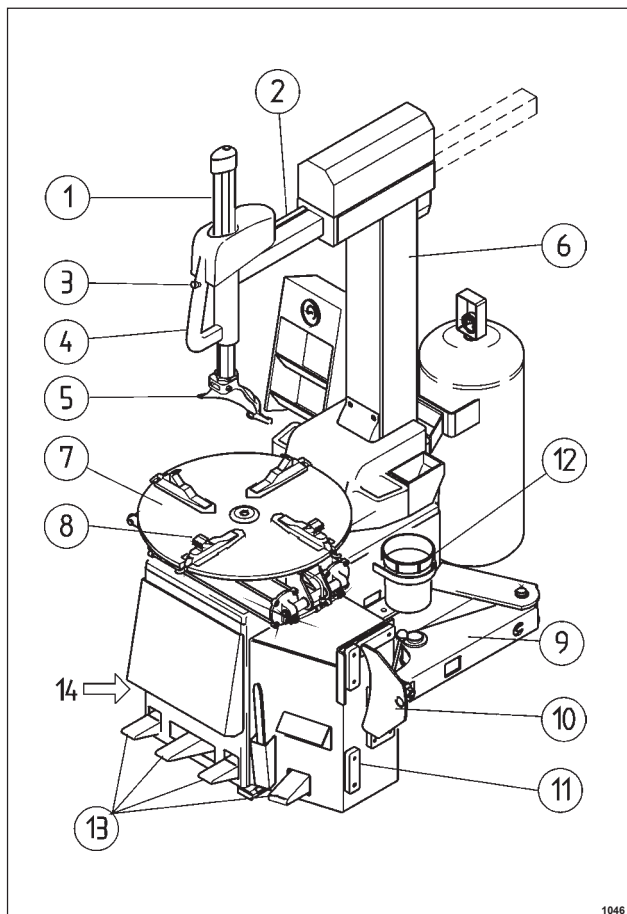

Fig. 1.1-1

1046

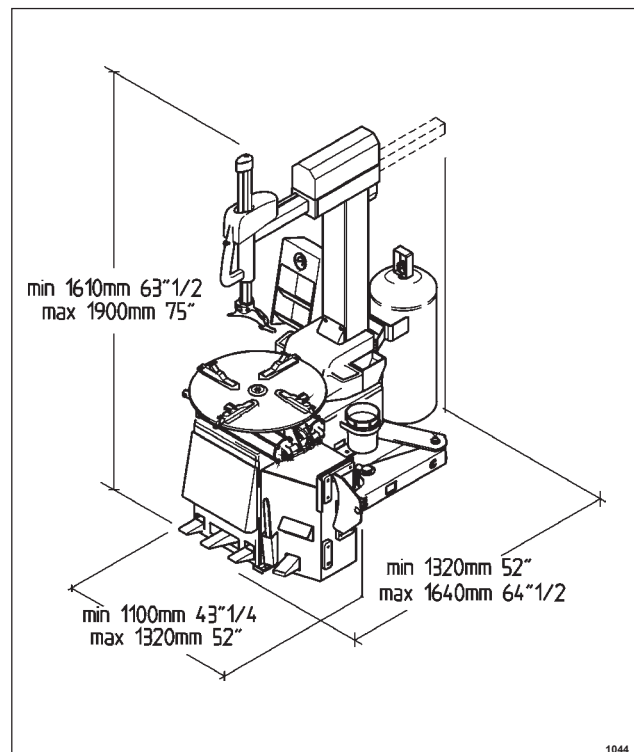

Fig. 1.3-1

1044

1.4 STANDARD ACCESSORIES

#0001418 bead lifting tool (Fig.1.4-1)

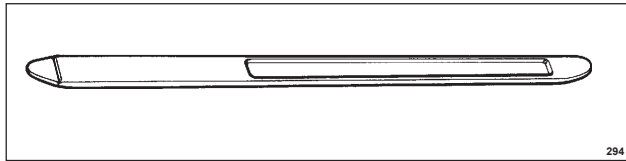

Fig.3

#4014528 Lube pail (Fig.1.4-2).



Fig.3a

#4025419 air filter-lubricator with water separator (Fig.1.4-3)

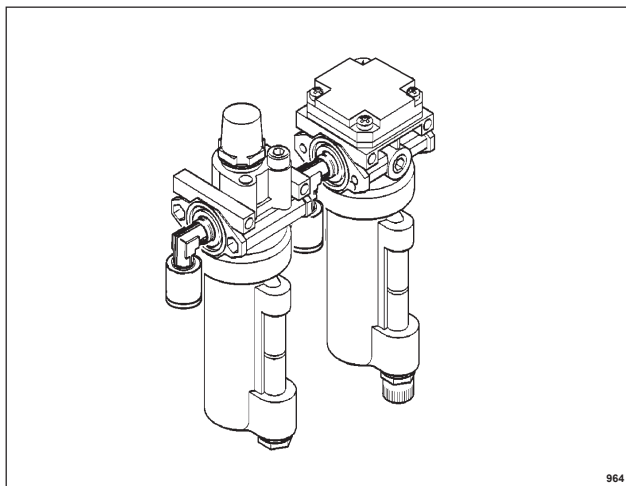

Fig. 4

NOTE:
ALTHOUGH IT IS SUPPLIED SEPARATELY, THE INFLATION GAUGE IS A STANDARD ACCESSORY TOO BUT IT HAS TO BE MOUNTED ON THE COLUMN LATER.

1.5 OPTIONAL ACCESSORIES

#4027908 Light alloy rim protector

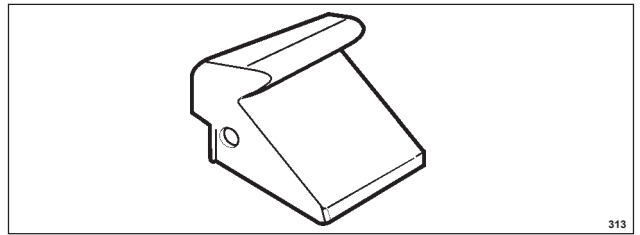

Fig. 1.5-1

To be slid onto the clamps of the turntable to prevent any possible damage to the rim when operating on light alloy rims (Fig.1.5-1).

#4003444 Bead depressing tool MX

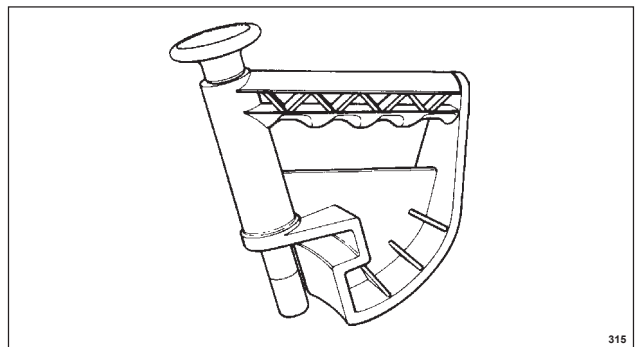

Fig. 1.5-2

Facilitates the mounting of the top bead especially on low profile and stiff tires (Fig.1.5-2).

#4008755 Motorcycle bead breaker blade

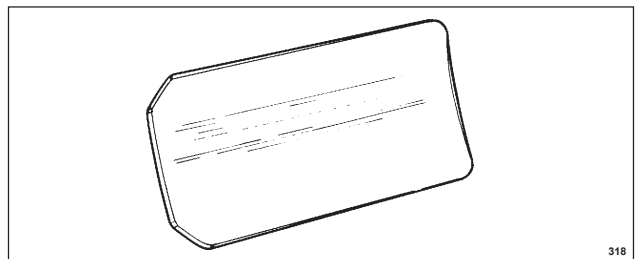

Fig. 1.5-3

To be attached to the bead breaker blade to facilitate loosening of motorcycle tyres (Fig.1.5-3).

#4028570 7"/Moto wheel adapter

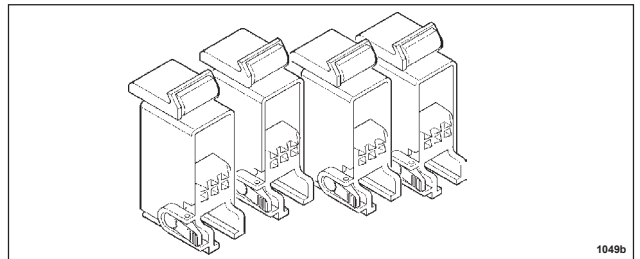

Fig. 1.5-4

To be attached to the clamps of the turntable to clamp motorcycle rims from the outside (Fig.1.5-4).

1.6 GENERAL PRECAUTIONS

A. DURING THE USE AND MAINTENANCE OF THE MACHINE IT IS MANDATORY TO COMPLY WITH ALL LAWS AND REGULATIONS FOR ACCIDENT PREVENTION.

B. THE ELECTRICAL POWER SOURCE MUST HAVE A GROUND CABLE AND THE GROUND CABLE OF THE MACHINE (YELLOW WITH GREEN) MUST BE CONNECTED TO THE GROUND CABLE OF THE POWER SOURCE.

C. BEFORE ANY MAINTENANCE OR REPAIRS ARE ACCOMPLISHED THE MACHINE MUST BE DISCONNECTED FROM THE AIR AND ELECTRICAL SUPPLY.

D. NEVER WEAR TIES, CHAINS OR OTHER LOOSE ARTICLES WHEN USING, MAINTAINING OR REPAIRING THE MACHINE. LONG HAIR IS ALSO DANGEROUS AND SHOULD BE KEPT UNDER A HAT. THE USER MUST WEAR PROPER SAFETY ATTIRE I.E.: GLOVES, SAFETY SHOES AND GLASSES.

D. KEEP SAFETY DEVICES IN PLACE AND IN WORKING ORDER.

E. KEEP WORKING AREA TIDY. CLUTTERED AREAS INVITE ACCIDENTS.

F. AVOID DANGEROUS ENVIRONMENTS. DON'T USE PNEUMATIC OR ELECTRICAL EQUIPMENT IN DAMP OR WET LOCATIONS, OR EXPOSE THEM TO RAIN.

G. KEEP THE WORK AREA WELL LIGHTED.

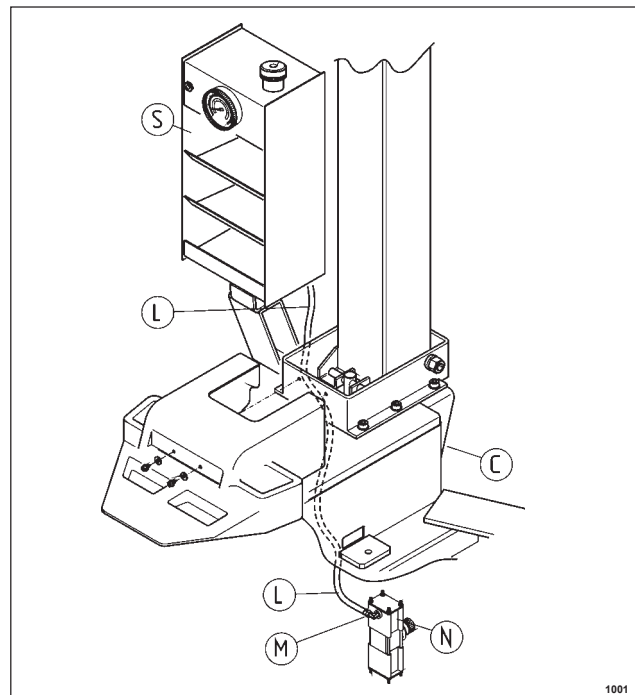

Fig. 2.0-1

B. Lift the column 'P' (Fig. 2.0-2) with an appropriate lifting tool (crane, fork lift) and a belt of sufficient capacity. For this operation it is required to be helped by a second person. BE CAREFUL NOT TO DAMAGE THE AIR HOSES. Introduce the air hoses 'T' through the hole 'G' of the cabinet 'C'.

2.0 INSTALLATION

Install the machine in a covered and dry area. The installation of the machine requires a free space of at least 86 1/2" x 106" (2200x2700mm). Make sure that from the operating position the user can see all of the machine and the surrounding area. The operator shall forbid, in such an area, the presence of non authorized persons and of objects which may create possible hazards.

The machine shall be installed on a horizontal floor preferably even. Do not install the machine on a sinking or irregular floor.

If the machine is installed on a raised floor, the floor must have a capacity of at least 500kg/m² or 110lbsxsqft (5000 N/m²). The machine must be secured to the floor through the holes provided in the cabinet. Expansion screws 12x120mm shall be used.

Drill 12mm holes in the floor flush with the holes provided in the cabinet.

Place the nogs into the holes drilled in the floor and move the machine so that the holes of the cabinet are flush with the holes in the floor. Tighten the screws at 51 ft·lb (70 Nm).

To install the machine proceed as follows:

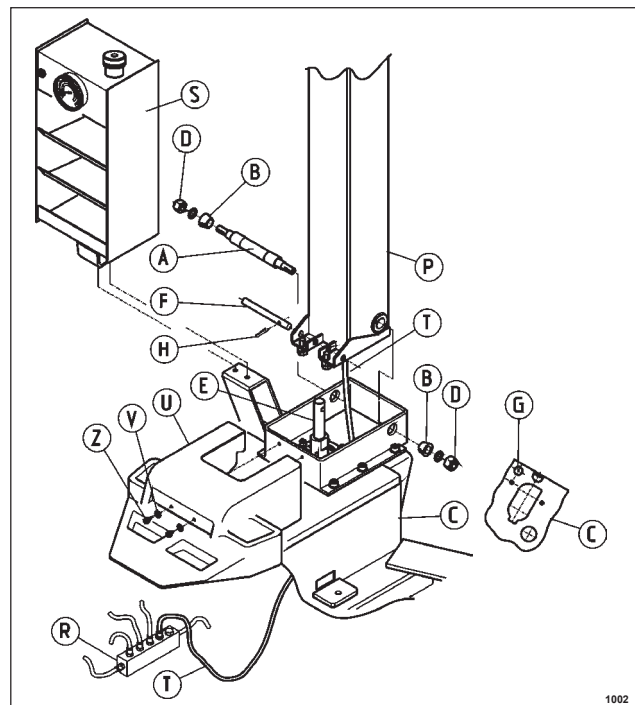

Fig. 2.0-2

C. Mount the column 'P' as shown in Fig. 2.0-2 and connect it to the cabinet through shaft 'A', nut 'D' and the conical bushings 'B'.

IMPORTANT!

THE NUTS 'D' MUST BE TIGHTENED ENOUGH TO ELIMINATE ANY SIDEWISE CLEARANCE BETWEEN THE COLUMN AND THE CABINET.

D.

Tilt the column backwards. Pull the rod 'E' of the tilting cylinder and connect it to the column with in 'F'. Lock pin 'F' with cotter pin 'H'.

E.

Attach air hose 'T' (Fig. 2.0-2) to pressure reducer 'R', laying on the bottom of cabinet 'C'.

F.

Fix the tool box 'S' with the available screws, as shown in Fig. 2.0-2.

G.

Connect the air hose 'L' (Fig. 2.0-1) coming from the tool box 'S' to the fitting 'M' of the device 'N' (Fig.92.0-1).

H.

Mount the cover 'U' (Fig. 2.0-2), by tightening the screws 'Z'
Mount the lube pail with the available screw.

K.

Secure the tire changer to the floor.

BEFORE USING THE BEAD SEATER TANK OF THE MACHINE, DEPENDING ON LOCAL LEGISLATION, IT MAY BE, THE TANK BE SUBJECTED TO A TEST IN PLACE OF USE

2.1 ELECTRIC INSTALLATION

WARNING!

ALL ELECTRICAL CONNECTIONS SHALL BE PERFORMED BY A LICENCED TECHNICIAN.

ALL SERVICE MUST BE PERFORMED BY AN AUTHORIZED SERVICE TECHNICIAN.

Check on the plate of the machine that the electrical specifications of the power source are the same as the machine.

The machine uses 0.75 KW

Electrical specifications are clearly marked on a label at the end of the electric cable.

Before connecting the machine to the power source check that the power supply has an efficient earthing system.

Connect the electric cable of the machine with an approved plug.

NOTE:

The outlet installation must be verified by a licensed electrician before connecting the tire changer.

NOTE:

The yellow/green wire in the cable is the earth wire. Never connect the earth wire to a live terminal. Check that the power supply has an automatic circuit breaker with a differential circuit rated at 30 mA. The electric motor operates in a wide voltage range (plus or minus 10%) and frequency range (50 or 60 Hz) and has a class of insulation suitable for hot and moist climates.

2.2 AIR INSTALLATION

WARNING!

THE AIR INSTALLATION MUST BE MADE ONLY BY LICENSED PERSONNEL.

WARNING!

EXCESSIVE AIR PRESSURE CAN SERIOUSLY INJURE PERSONNEL AND DAMAGE THE MACHINE.

Ensure that the line pressure is within the limits required by the machine. If the pressure exceeds 170 psi (12 bar) it is mandatory to install a pressure regulator before the air inlet of the machine.

If the air pressure is lower than the minimum required of 110 psi (8 bar) the clamping power of the turntable and the bead breaker power may be insufficient for certain tires.

It is suggested that the air supply be equipped with a water separator and air lubricator.

After ensuring all the above proceed as follows:

A. Connect the machine to the air supply with a rubber hose (rated for the pressure) with an internal diameter of no less than 1/4" (6mm).

WARNING!

BEFORE CONNECTING THE MACHINE TO THE AIR SUPPLY BE SURE ALL PERSONNEL ARE CLEAR OF THE MACHINE AND THAT NOTHING IS LEFT ON THE TURNTABLE AREA (TOOLS)

B. Should you install any optional accessories, please refer to the relevant instructions.

C. Should an air lubricator be installed, ensure the functional ability of the unit.

3.0 CONTROLS

Before operating the machine ensure that you have well understood the operation and function of all the controls (Fig.3.0-1).

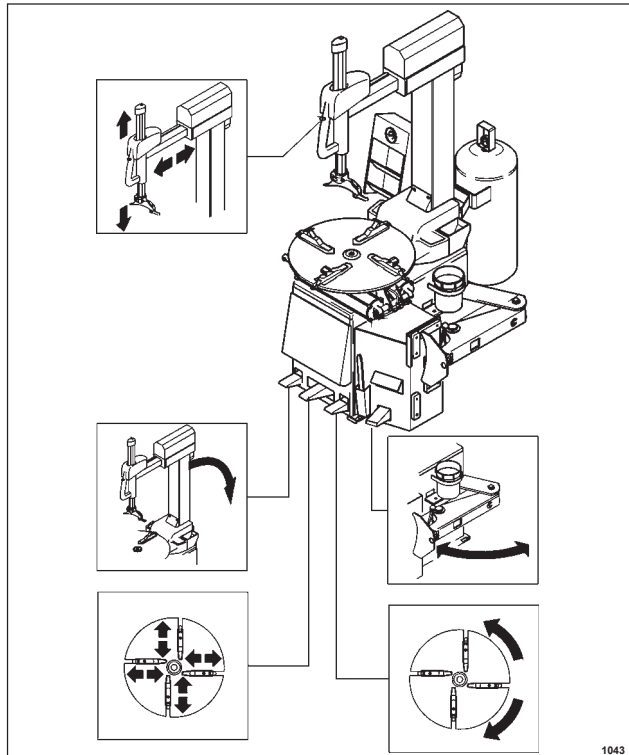

Fig. 3.0-1

A. Press down and release, WITH LEFT FOOT, the first pedal from the left: the column tilts backwards. Do it again: the column tilts forward.

DANGER OF BODY CRUSHING

B. Press down and release, WITH LEFT FOOT, the second pedal from the left: the clamps of the turntable will retract. Do it again: the clamps will expand. If you press the pedal prior to the end of the stroke and release, the clamps may be stopped in any position.

N.B.: The turntable jaws can be positioned in two different way. Push its lever on the left side of each jaw and shift at the same each one (Fig.3.0-2). Turntable capacity can be changed before pedal control.

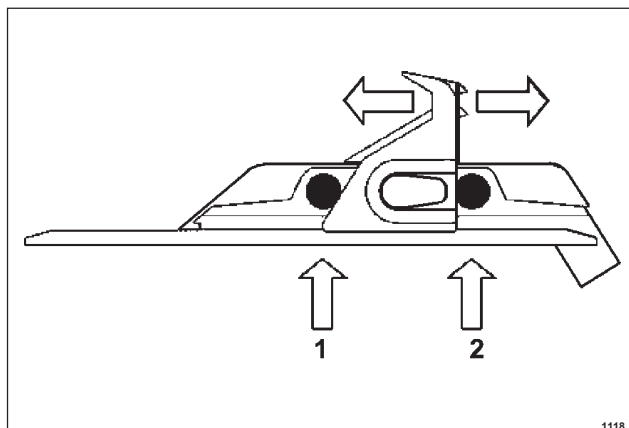

Fig. 3.0-2

C. Press down and hold, WITH SECOND FOOT, the first pedal from the right: the turntable turns clockwise.

1. 3/4 down approximately, the turntable rotates at the minimum speed (10 rpm approx.). The torque is maximum in this condition.

2. All the way down the turntable rotates at the maximum speed (10 rpm approx.).

Lift the pedal and the turntable turns counter-clockwise.

D. Open the bead breaker arm. Press down and hold, WITH RIGHT FOOT, the first pedal from the right: by doing this you operate the bead breaker blade and the arm will

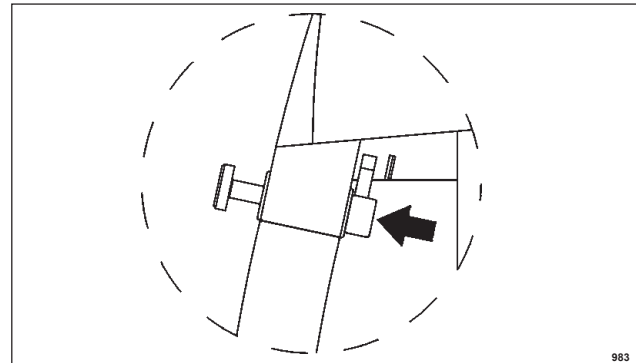

Fig. 3.0-3

move towards the machine. Release the pedal: the bead breaker blade will retract.

DANGER OF LEG TRAPPING

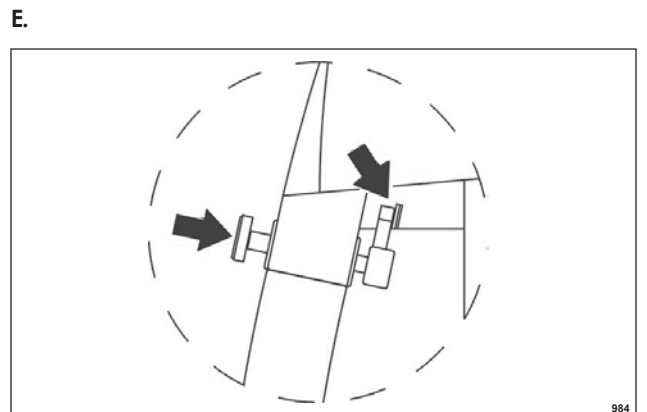

Fig. 3.0-4

The push button on the handle allows to release the arms and position the mount/demount tool in the correct position.

1. To unlock and let the slide with the tool go up: push the button firmly with the forefinger, in the direction of the

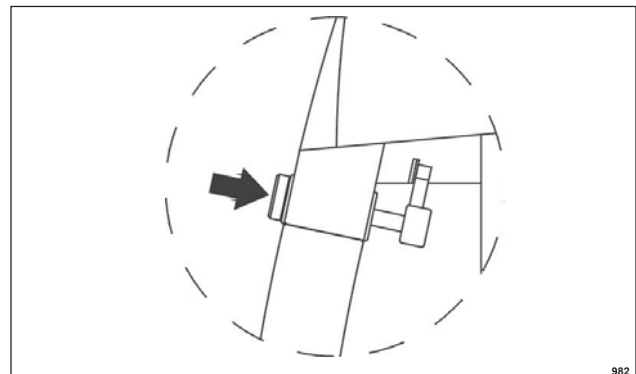

Fig. 3.0-5

arrow (Fig.3.0-3).

2.

To unlock and let the slide with the tool go down: push the button with the thumb in the direction of the arrow, until the resistance increases (Fig.3.0-4)

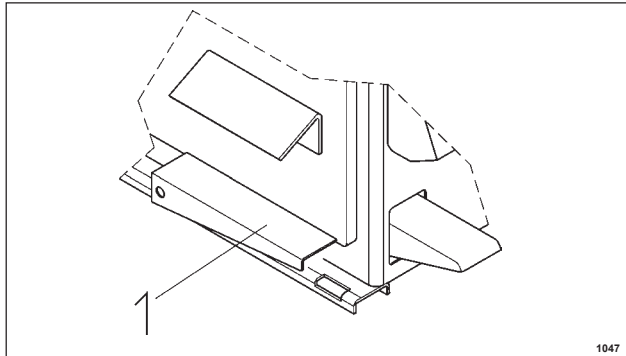

Fig. 3.0-6

3.

To lock: push the button firmly with the thumb (Fig.3.0-5)

DANGER OF HAND CRUSHING

F.

Press bead seater/inflator pedal on left side of the machine down (#1 Fig.3.0-6): air will come from inflation hose end.

G.

On model with bead seater:

Press bead seater/inflator pedal on left side of the machine half way down (#1 Fig.3.0-6): air will come from inflation hose end only.

H.

Press bead-seater pedal down swiftly to get air blast from the inflator jets. Air simultaneously comes out of inflator hose.

WARNING!

WHEN OPERATING THE BEAD SEATER AND INFLATOR IT IS MANDATORY TO WEAR EAR PROTECTORS AND SAFETY GLASSES TO PREVENT CONTAMINATION FROM NOISE, DUST AND CHIPS BLOWN BY THE AIR JETS.

DANGER OF TIRE EXPLOSION

4.0 MOUNTING AND DEMOUNTING PRECAUTIONS

IMPORTANT!

BEFORE MOUNTING A TIRE ON A RIM, PAY ATTENTION TO THE FOLLOWING:

A. THE RIM MUST BE CLEAN AND IN GOOD CONDITION: IF NECESSARY CLEAN AND PAINT IT AFTER REMOVING ALL WHEEL-WEIGHTS TO INCLUDE 'TAPE WEIGHTS' INSIDE THE RIM.

B. THE TIRE MUST BE CLEAN AND DRY, WITHOUT ANY DAMAGE TO THE BEAD.

C. REPLACE THE RUBBER VALVE STEM WITH A NEW ONE OR REPLACE THE 'O' RING IF THE VALVE STEM IS MADE OF METAL.

D. IF THE TIRE REQUIRES A TUBE, MAKE SURE THE TUBE IS DRY AND IN GOOD CONDITION.

E. LUBRICATION IS NECESSARY TO MOUNT THE TIRE CORRECTLY AND GET A PROPER CENTERING. BE SURE YOU ARE USING APPROVED LUBRICANT ONLY.

F. MAKE SURE THE TIRE IS THE CORRECT SIZE FOR THE RIM.

4.1 DEMOUNTING TUBELESS TIRES

A.

Remove all wheel-weights from the rim. Remove the valve stem or core and deflate the tire (Fig.4.1-1).

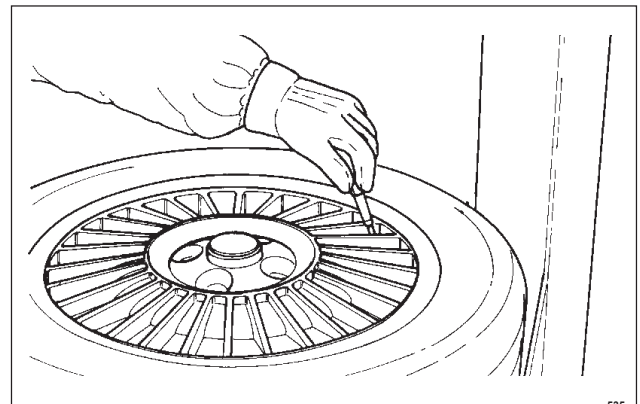

(Fig.4.1-1)

B.

Break outer bead starting from opposite the valve position.

lubricate the bead and rim with a tire lube only.

Break inner bead. Do not hold the foot pedal depressed longer than necessary since this could damage the bead.

Liberaly lubricate bead and rim.

C.

Set the rim clamps to the proper position: retract clamps to clamp the wheel from the inside and expand clamps to clamp from the outside.

When clamping small wheels (14" or smaller) from the outside, set the clamps at diameter nearly equal to the rim diameter, before placing the wheel on the clamps. This will avoid the risk of pinching the tire.

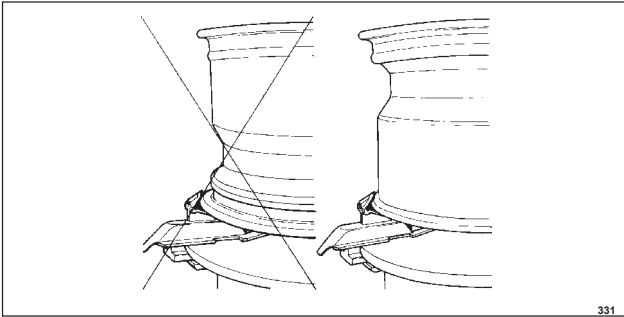

(Fig.4.1-2)

TO MINIMIZE THE RISK OF SCRATCHING ALLOY RIMS, THESE SHOULD BE CLAMPED FROM THE OUTSIDE.

D.
Place the wheel WITH DROP CENTER UPWARDS (Fig.4.1-2) on the turntable, and clamp in position.

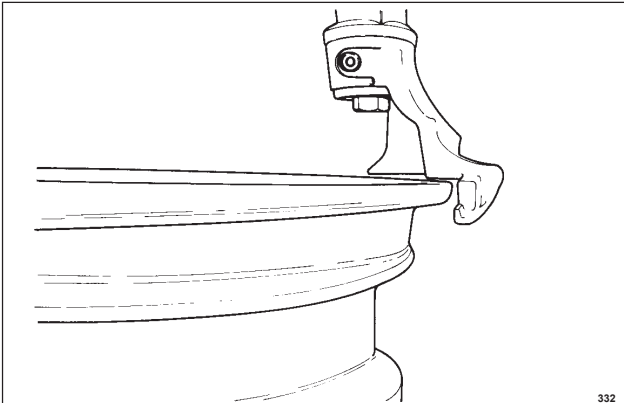

(Fig.4.1-3)

E.
Position the mount/demount head in contact with the rim edge and lock it into place: the tool automatically moves away from the rim edge vertically. And horizontally, to avoid rim damage (Fig.4.1-3).

NOTE:
ONCE THE MOUNT/DEMOUNT HEAD IS POSITIONED PROPERLY, MATCHING WHEELS MAY BE CHANGED WITHOUT HAVING TO RESET THE HEAD.

NOTE:
THE PLASTIC INSERT INSIDE THE MOUNT/DEMOUNT TOOL MUST BE PERIODICALLY REPLACED. EVERY MACHINE IS EQUIPPED WITH SEVERAL PLASTIC INSERTS (INSIDE STANDARD EQUIPMENT BOX).IF DESIRED, THE PLASTIC INSERT MAY BE REPLACED BY A STEEL ROLLER ALSO INCLUDED IN THE STANDARD EQUIPMENT BOX. FOLLOW THE INSTRUCTIONS INCLUDED WITH THE REPLACEMENT PARTS.

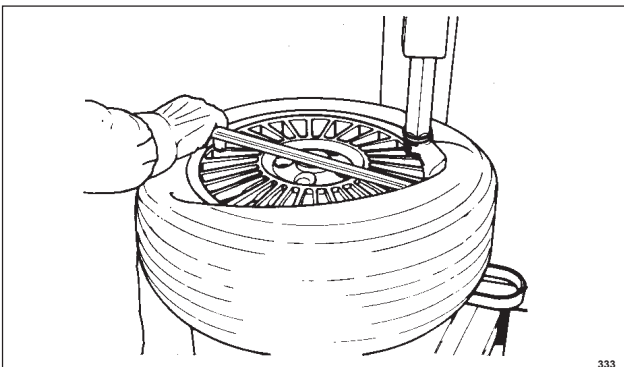

(Fig.4.1-4)

F.
Insert the bead lifting tool under the bead and over the support of the mount/demount tool. Lift the bead onto the mounting finger (Fig.4.1-4). To facilitate this operation, press with left hand on the bead in position diametrically opposite to that of the tool. If desired, the bead lifting tool can be removed after lifting the bead onto the finger (Fig.4.1-5).

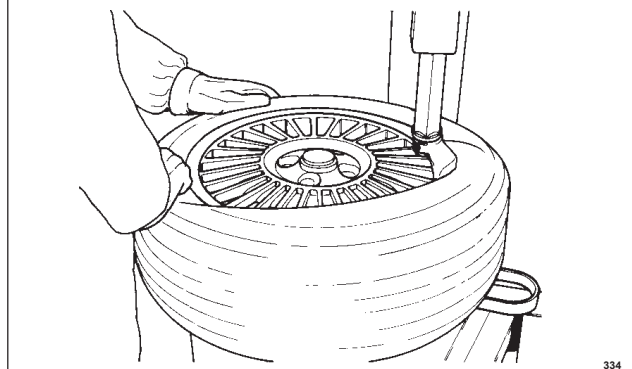

(Fig.4.1-5)

G.
Rotate the turntable clockwise and at the same time push down on the tire sidewall to move the bead into the drop-center of the rim (Fig.4.1-6).

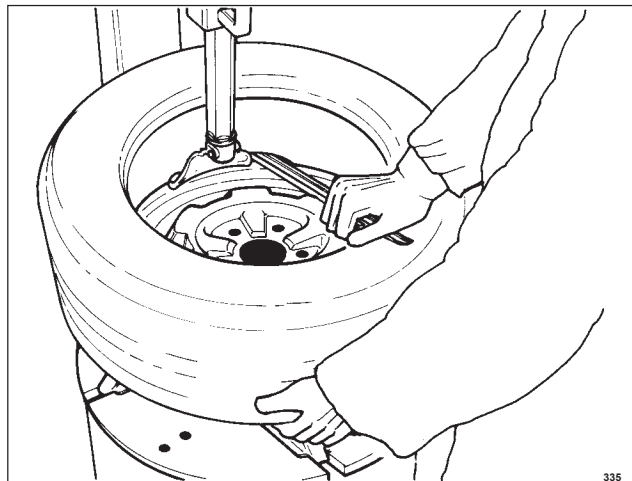

(Fig.4.1-6)

4.2 MOUNTING TUBELESS TYRES

A.
Lubricate the entire rim surface (Fig.4.2-1).
Lubricate both beads, inside and outside, (Fig.4.2-2).

OBSERVE THE ROTATION DIRECTION OF THE TIRE, IF REQUIRED. SOME TYRES HAVE A COLOR DOT THAT MUST BE KEPT ON THE OUTSIDE OF THE WHEEL.

LIBERAL LUBRICATION OF THE TIRE AND RIM IS NECESSARY TO MOUNT TIRE CENTERING CORRECTLY AND GET A PROPER ON THE RIM. BE SURE YOU ARE USING APPROVED LUBRICANT ONLY.

B.
Lock the rim on the turntable and rotate it to have the valve in 5 o'clock position. Place the tire to be

mounted on the rim. Tilt the column forward so that the mount/demount tool is in the working position.

ENSURE THAT THE MOUNT/DEMOUNT TOOL IS NOT PRESET TO A WRONG POSITION SO THAT IT WILL HIT THE RIM EDGE AND CREATE AN HAZARD, BEFORE TILTING THE COLUMN FORWARD.

Engage the lower bead OVER the mounting wing and UNDER the mounting finger of the mounting tool. Turn the wheel clockwise and push the tire down into the drop center, opposite to the mount/demount head (Fig. 4.2-3).

C.
Mount the upper bead following the directions in section B (Fig.4.2-4). With low profile tyres the bead depressor tool "MX" (optional #4003444) can help to facilitate mounting of the top bead.

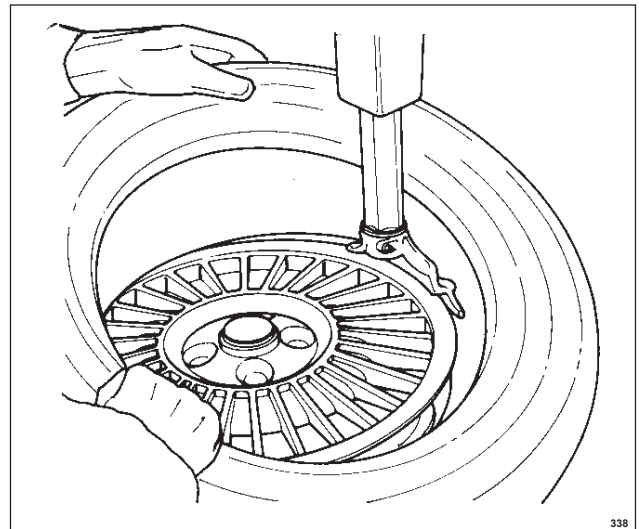

(Fig.4.2-3)

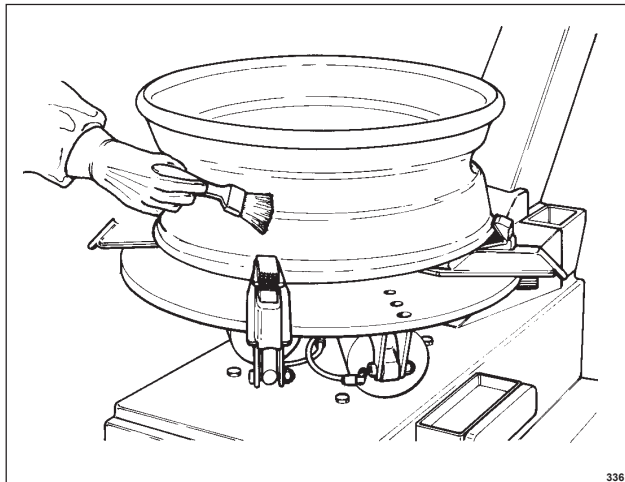

(Fig.4.2-1)

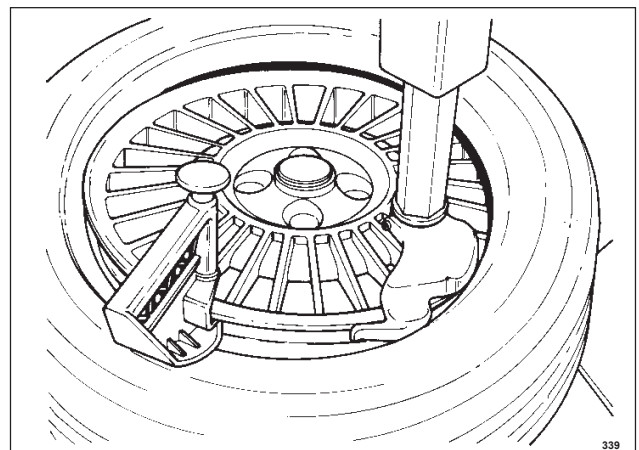

(Fig.4.2-4)

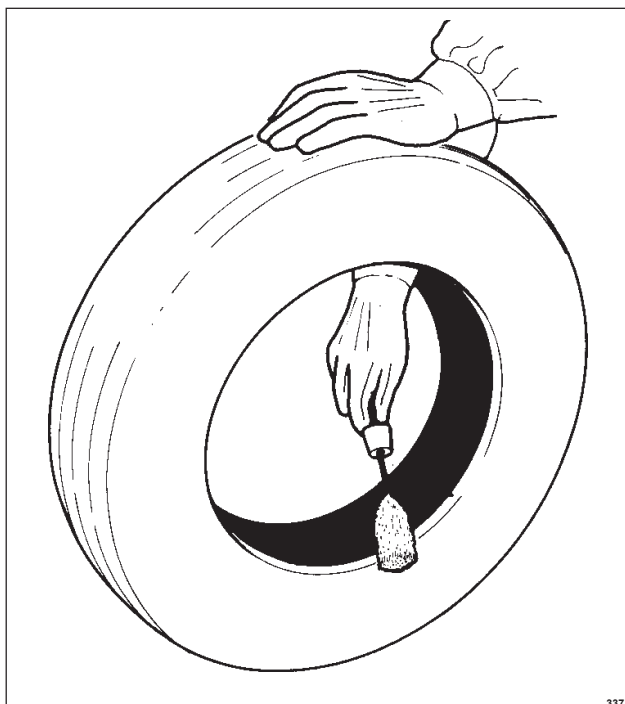

(Fig.4.2-2)

4.3 INFLATION OF TUBELESS TIRES

Make sure that both beads are properly lubricated. Inflate the tire and ensure that both beads are properly seated. Inflate to correct pressure.

NEVER EXCEED THE MAXIMUM PRESSURE ALLOWED BY THE TIRE MANUFACTURER.

THE RIM MUST BE UNCLAMPED WHEN INFLATING BUT ONLY AFTER BEADS HAVE BEEN SEATED.

THE OPERATOR MUST STAND CLEAR FROM THE WHEEL WHEN INFLATING, AND PRESSURE MUST BE MONITORED FREQUENTLY TO AVOID OVER-INFLATION.

BEFORE INFLATING A TIRE, CHECK THE CONDITION OF TIRE AND RIM.

CHECK THE CORRECT SEALING OF THE VALVE AND THE FITTING AT THE END OF THE INFLATION HOSE. AN AIR LEAK MAY LEAD TO WRONG PRESSURE READINGS AND CREATE SAFETY HAZARDS.

CHECK THAT THE READING ON THE MANOMETER IS "ZERO" WHEN AT REST.

BEAD SEATING IS THE MOST DANGEROUS PART OF MOUNTING A TIRE.

IT IS POSSIBLE TO MOUNT TIRES THAT ARE 1/2" SMALLER IN DIAMETER THAN THE RIM THEY ARE MOUNTED ON. WHILE THESE BEADS WILL SEAL, IT IS IMPOSSIBLE TO GET THEM TO SEAT IN THEIR PROPER POSITION.

EXPLOSION OF A TIRE MAY CAUSE SEVERE INJURY OR DEATH.

Inflation of tubless tires is sometimes difficult because the beads may be very close together (owing to incorrect stacking) and will not seal onto the rim.

In such a case the wheel may be placed on the floor in a vertical position and made to jump slightly, while inflating with the tire gauge.

The BOXER SUPER LX-GT model is equipped with a device to facilitate bead seating. Proceed as follows:

- A.**
If possible lock the wheel from inside. Outside locking reduces efficiency of the bead seater.
- B.**
Connect the inflation hose to the valve stem.
- C.**
Lift the tire with both hands so that upper bead is sealed to the rim edge (Fig. 4.3-1).
- D.**
Press the inflation pedal down swiftly. The top bead is already sealed by the lifting motion. The air from the bead seater jets will rebound into the bottom sidewall driving it into place and creating a seal.

ATTENTION!
WHEN OPERATING THE BEAD SEATER AND INFLATOR IT IS MANDATORY TO WEAR EAR PROTECTORS AND SAFETY GLASSES TO PREVENT CONTAMINATION FROM NOISE, DUST AND CHIPS BLOWN BY THE AIR JETS.

- E.**
Complete inflation as described at the beginning of this section.

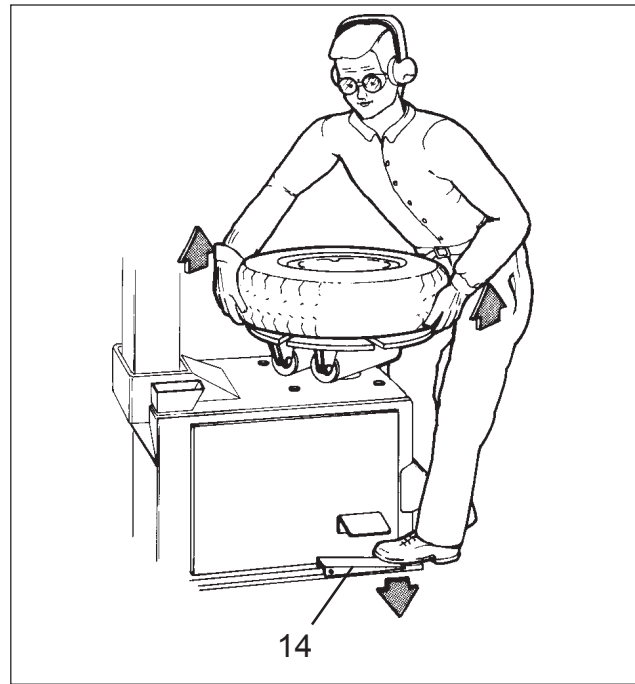

(Fig.4.3-1)

5.0 DEMOUNTING TUBE-TYPE TIRES

- A.**
To demount the tire operate as described for tubeless tires in section 5.1.A through section 5.1.G. In this case the valve cannot be replaced because it is part of the tube.

WARNING!
BE CAREFUL NOT TO DAMAGE THE TUBE DURING THE BEAD-BREAKING OPERATION. THE VALVE SHOULD BE OPPOSITE TO THE BLADE OF THE BEAD BREAKER.

- B.**
To demount the first bead, place the valve at 3 o'clock position.

WARNING!
DO NOT CATCH THE TUBE WITH THE BEAD LIFTING TOOL, WHEN LIFTING THE BEAD ON THE MOUNTING FINGER.

After demounting the first bead remove the tube before demounting the second bead, as described in section 5.1.H.

5.1 MOUNTING TUBE-TYPE TIRES

- A.**
Proceed as described in section 5.2.A. Do NOT lubricate the tube. Talc can be used to assist with the tube positioning.

- B.**
Mount the valve core and place the tube onto the tire to confirm that the tube is of the correct size (Fig.5.1-1).

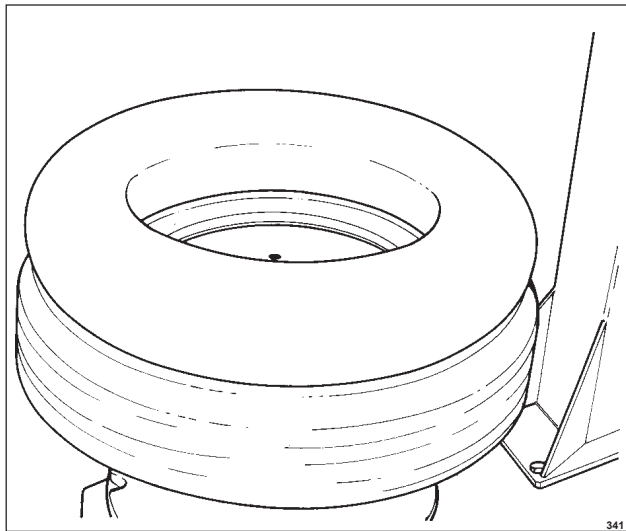

(Fig.5.1-1)

C.
Inflate the tube slightly; if held with the index finger it should bend a little (Fig.5.1-2).

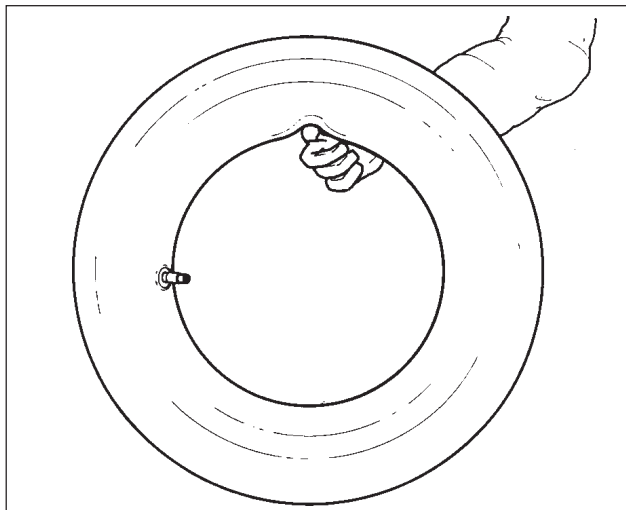

(Fig.5.1-2)

D.
Mount the first bead as described in section 5.2.B. Put the tube inside the tire and secure the valve with the chuck of the inflating hose (Fig. 5.1-3). Mount the top bead following the directions above.

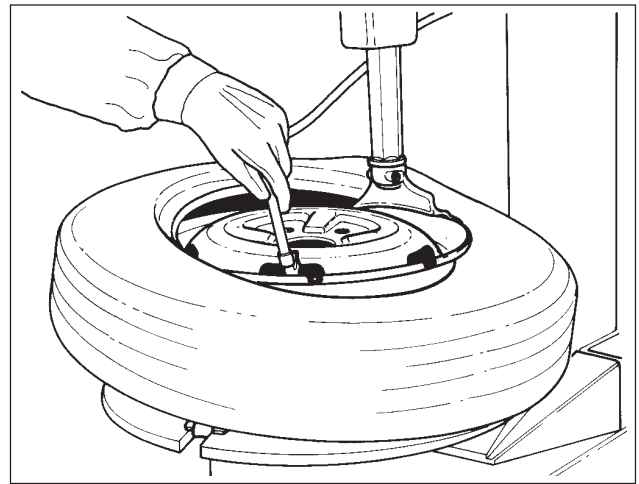

(Fig.5.1-3)

5.2 INFLATING TUBE-TYPE TIRES

To inflate the tire unlock the rim and start inflating while pressing the valve towards the inside. This is necessary to avoid air pockets forming between tube and tire (Fig.5.2-1).

Ensure that the tire is correctly centered on the rim and complete inflation as described in section 4.3.

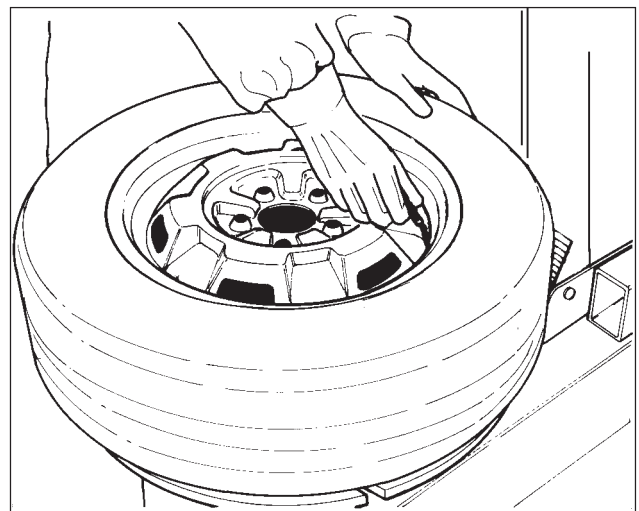

(Fig.5.2-1)

6.0 MOUNTING AND DEMOUNTING MOTORCYCLE TIRES

To mount and demount motorcycle tires it is necessary to utilize the optional motorcycle adaptors (4 piece #4015099).

The bead-breaking, mounting and demounting technique is the same as per car tires.

WARNING!
MOTORCYCLE RIMS MUST ALWAYS BE CLAMPED FROM THE OUTSIDE. AIR PRESSURE MUST NOT EXCEED 10 BAR (140 PSI) WHEN CLAMPING MOTORCYCLE RIMS.

7.0 MAINTENANCE

WARNING!
BEFORE ATTEMPTING ANY MAINTENANCE OR REPAIRS THE MACHINE MUST BE DISCONNECTED FROM THE AIR AND ELECTRIC SUPPLY.

A.
 Periodically clean the vertical hexagonal rod with nonflammable liquid detergent. Lubricate with oil (Fig.7.0-1).

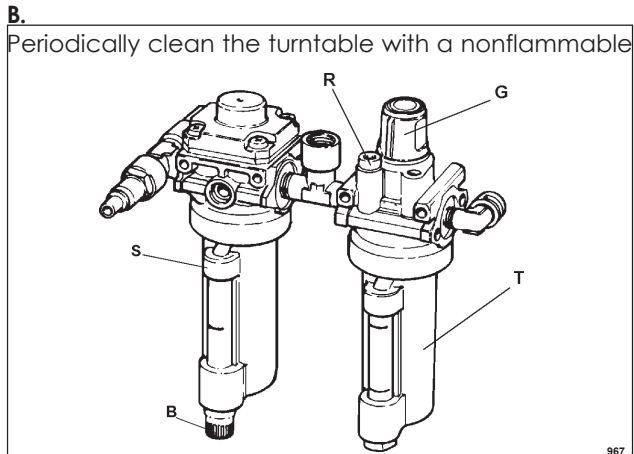

liquid detergent, dry and lubricate the sliding surface of the clamps with oil.

C.
 Clean the teeth of the clamps with a wire brush, check the plastic rim protectors and replace if worn (Fig.7.0-2).

D.
 Periodically wash all plastic parts with cold water and

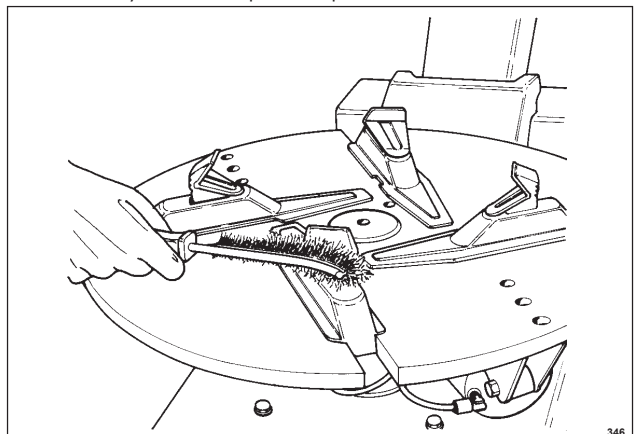

soap or mild chemical detergent.

E.
 Periodically lubricate rods of air cylinders with oil.

F.
 Grease every 4 months the shaft that connects the column to the cabinet. Add grease through the greas-

ing nipple (Fig.7.0-3).

G.
 Check the bead breaker pads. Replace if worn.

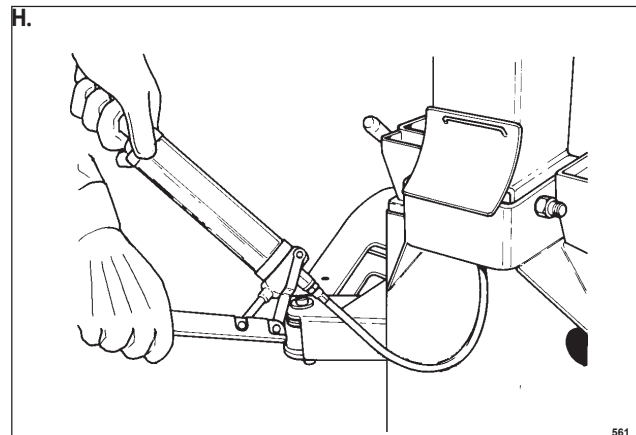

Daily drain water from water separator 'S'. Do this by pulling down fitting 'B' (Fig.7.0-1).

I.
 Check the oil level weekly. When adding oil to the lubricator, disconnect the air supply first, remove the metal cup 'T' (Fig. 7.0-1) by twisting 1/4 turn counter clockwise, and add oil as needed. Make sure seals are in place when repositioning the cup.

WARNING!
USE ONLY OILS FOR AIR DEVICES, DO NOT USE BRAKE FLUID OR OTHER NON RECOMMEND LUBRICANTS.

Suggested oils for the filter/lubricator unit:

TAMOIL:	WHITE MINERAL OIL 15
SHELL:	ONDINA OIL 15
BP:	ENERGOL WT3
TOTAL:	LOBELIA SB 15
ESSO:	MARCOL 82

J.
 Periodically check the lubricator efficiency. One drop 'G' (Fig.7.0-1) every 4-5 operations of the bead breaker indicates that the correct amount of oil is being dispersed in the system. If necessary adjust the oil flow with screw 'R' (Fig.7.0-1).

k.
 If the machine is equipped with a tank for tubeless inflation, drain condensation from the tank daily.

8.0 SPARE PARTS



WARNING! THIS PART IS FOR USE OF AUTHORIZED TECHNICAL PERSONNEL ONLY

ACCU 5602

SPARE PARTS EXPLODED DRAWINGS

PNEUMATIC DIAGRAM

On order specify: type of machine and serial number, item code and quantity.

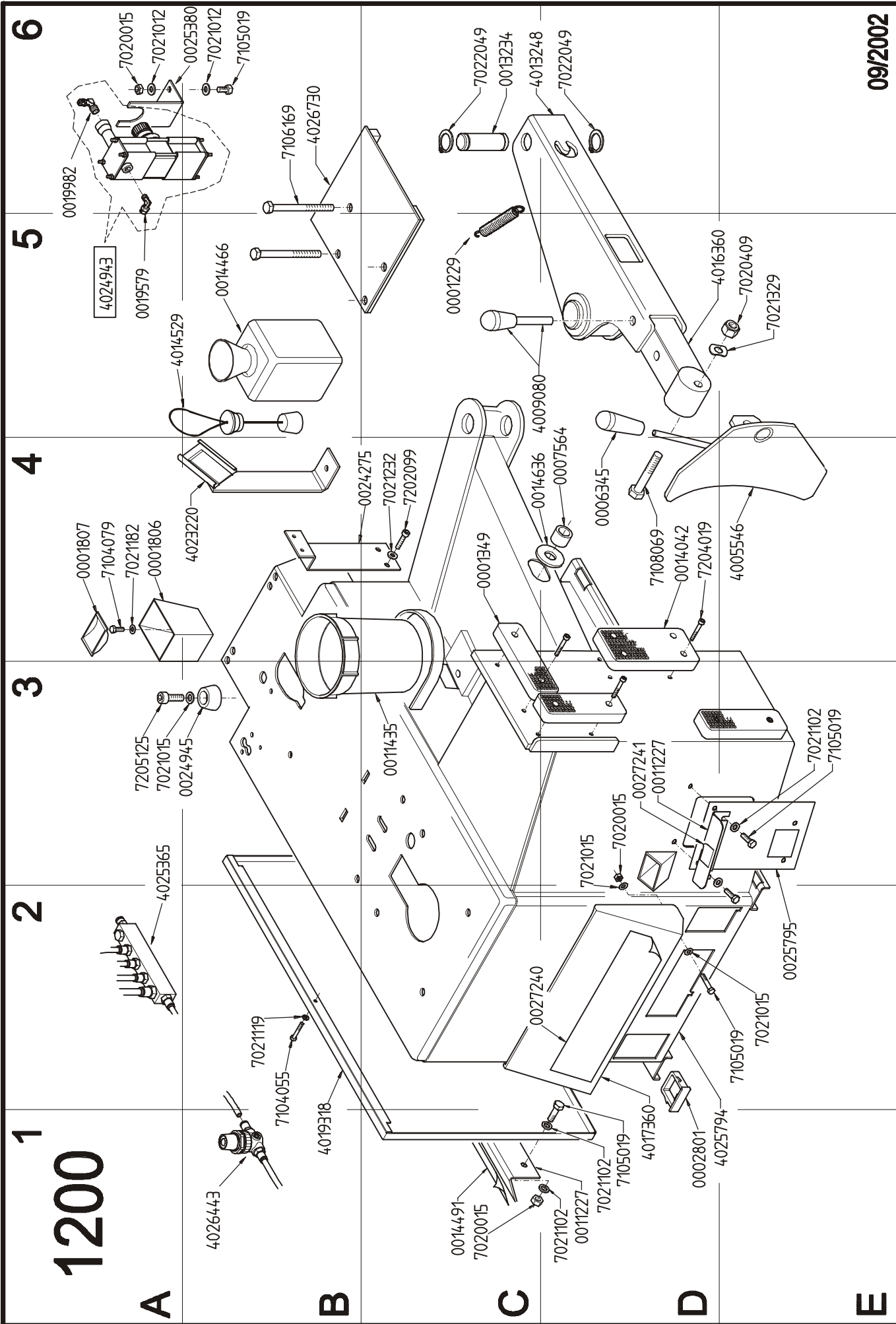

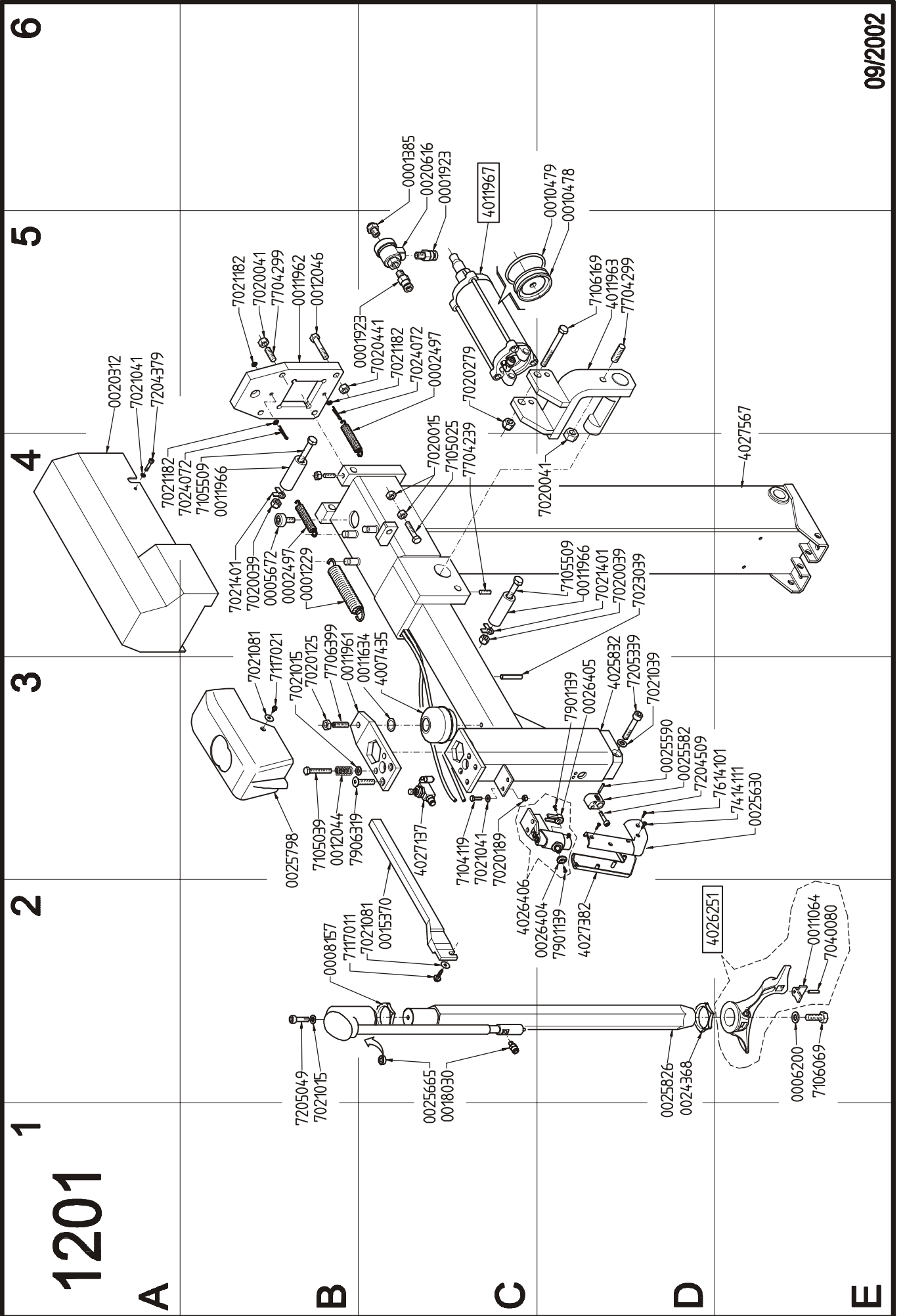

1084.b

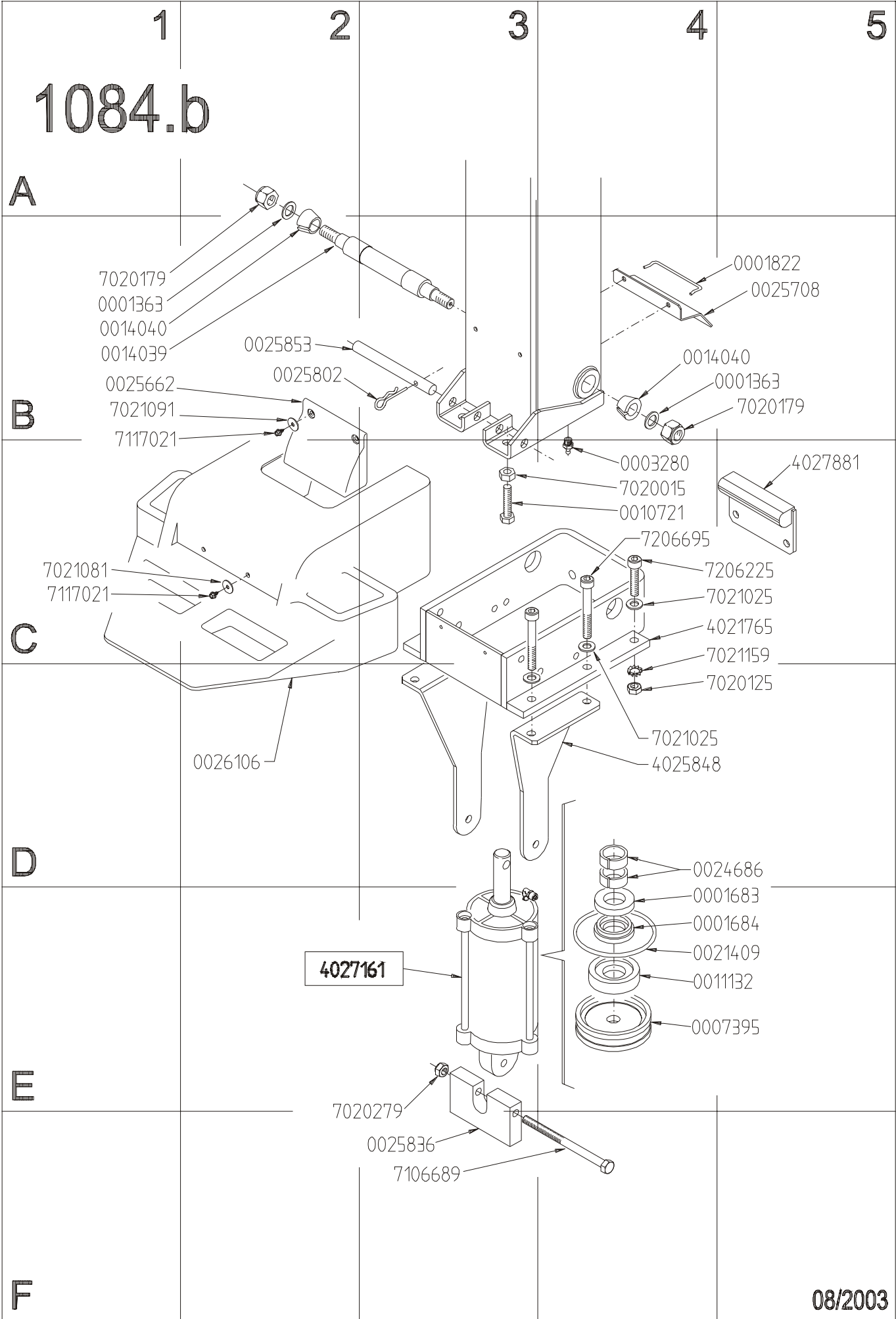

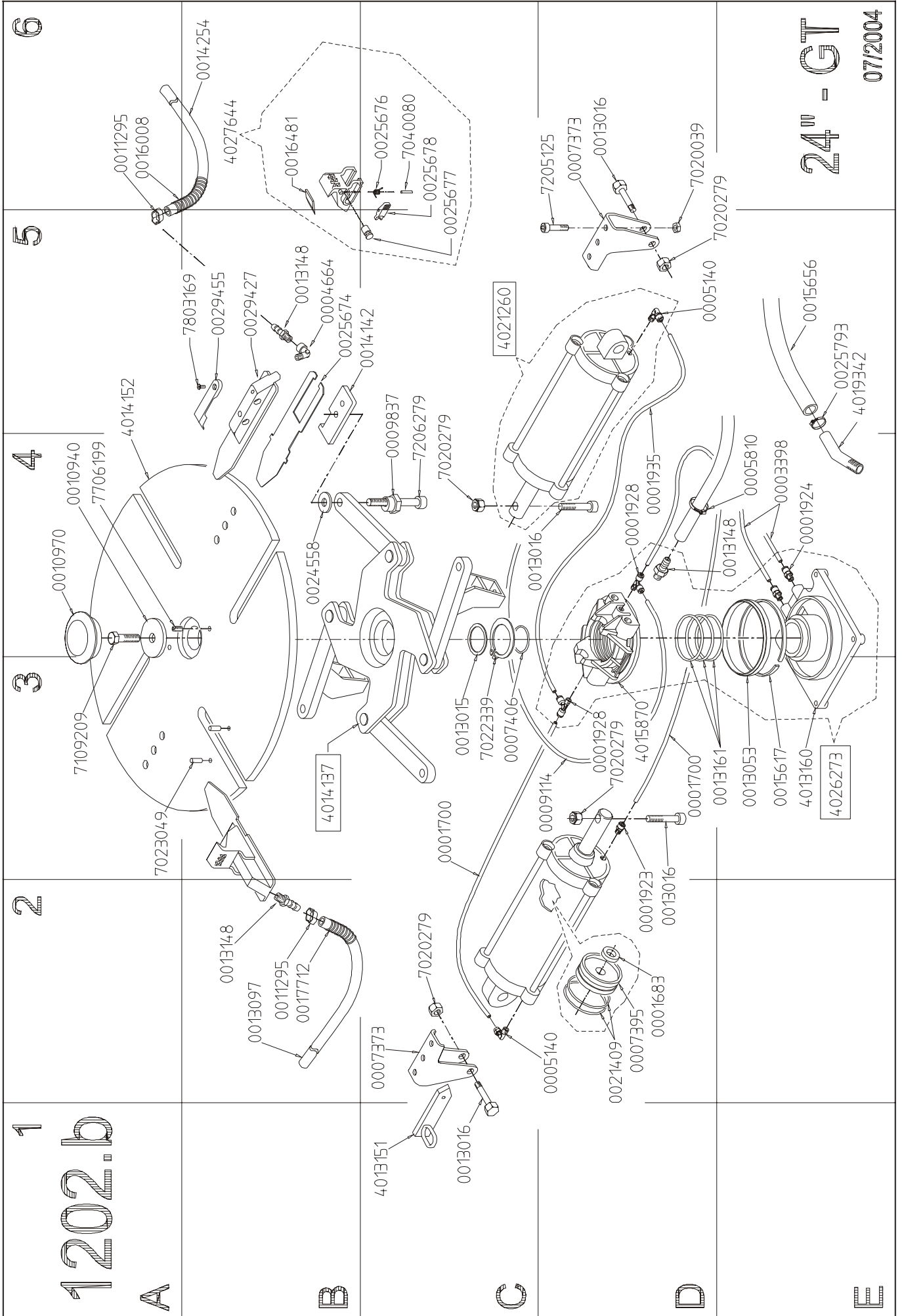

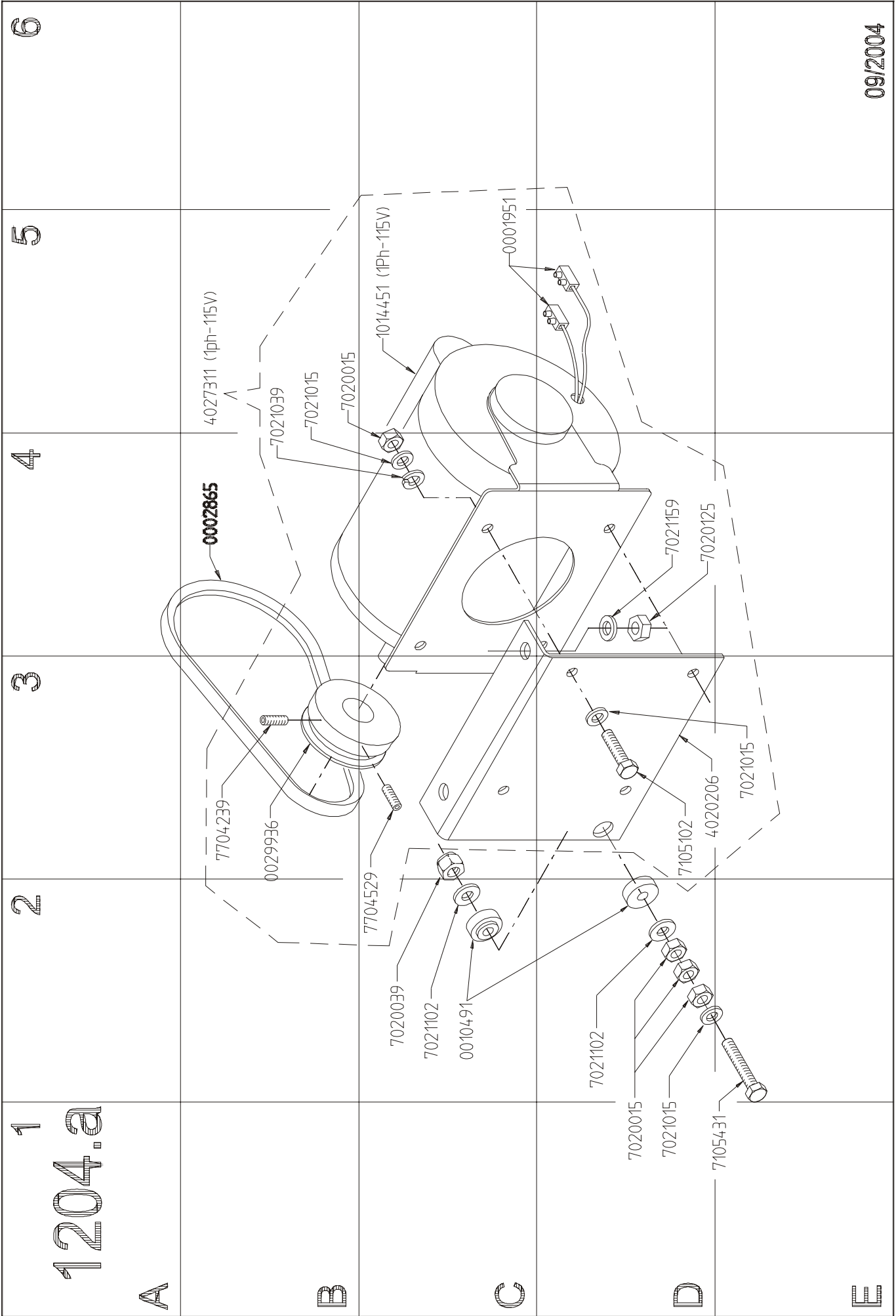

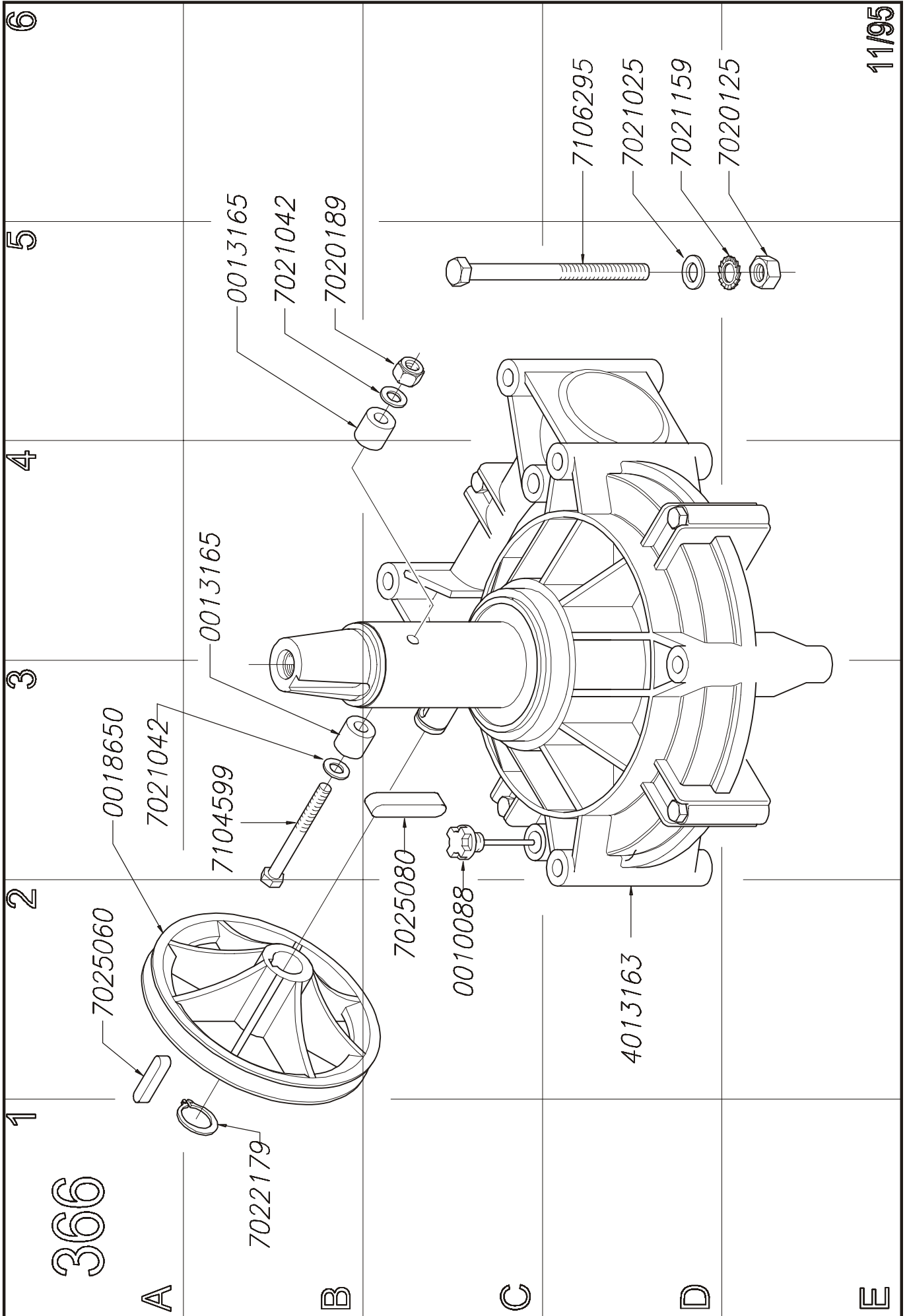

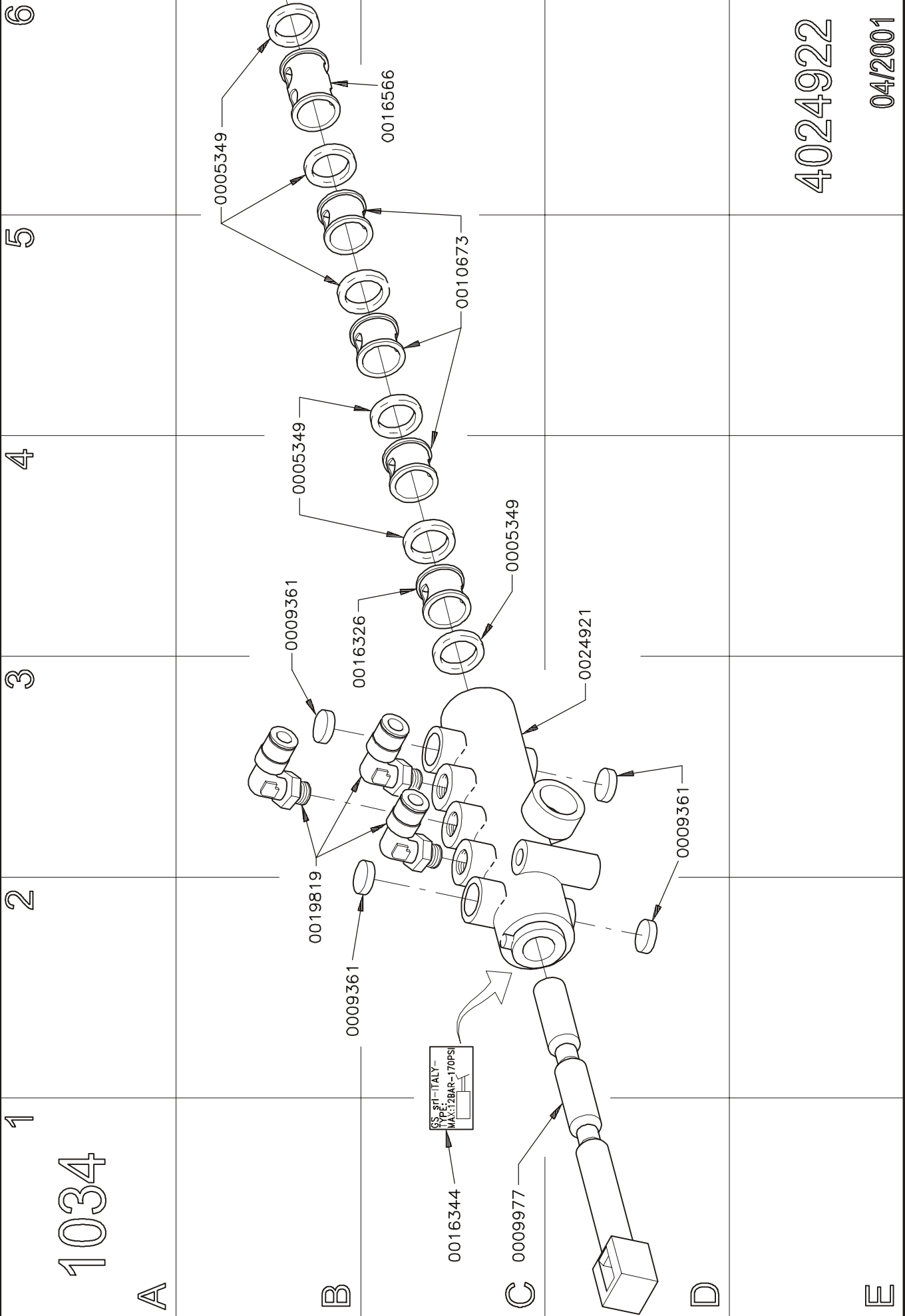

4024922

04/2001

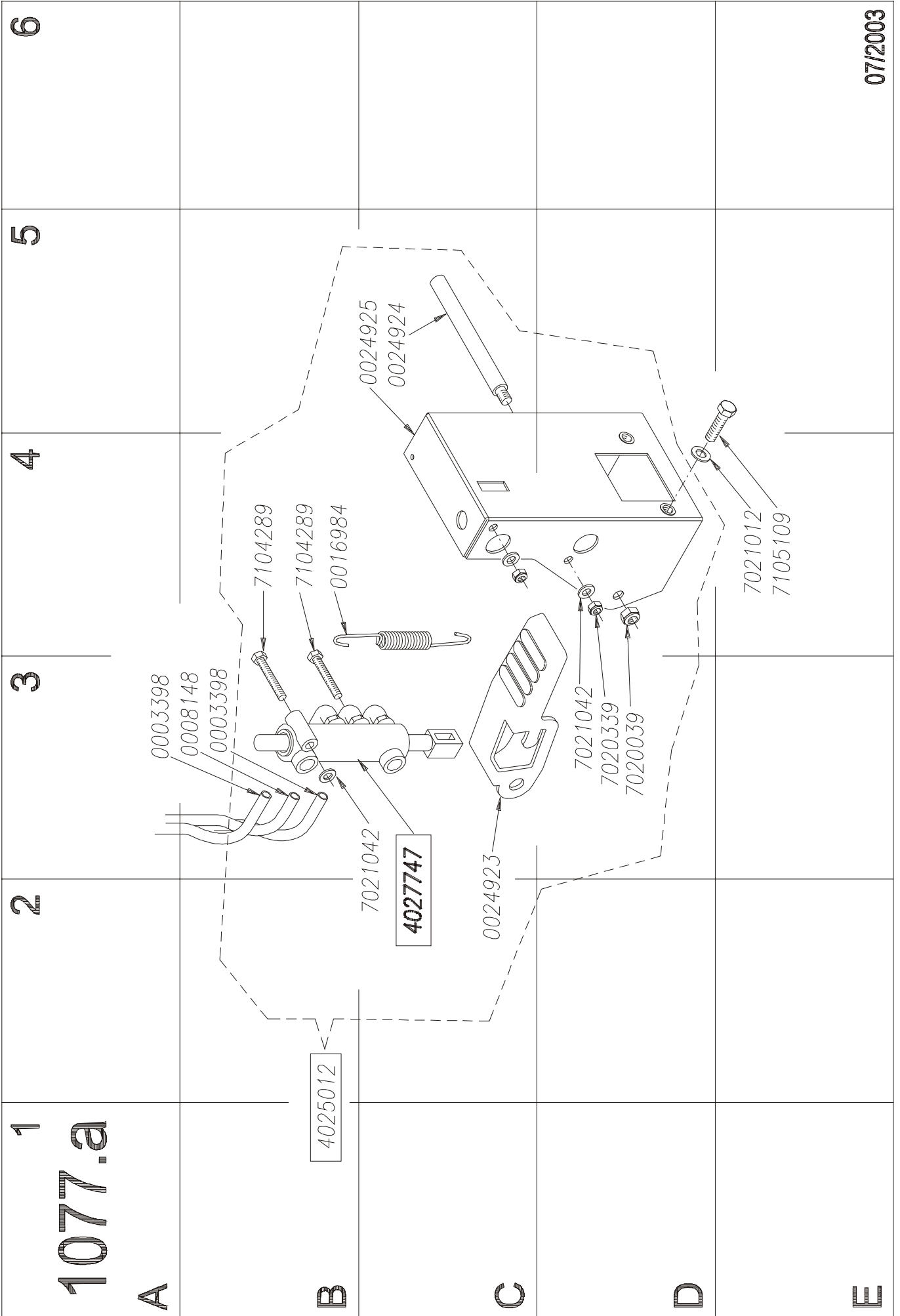

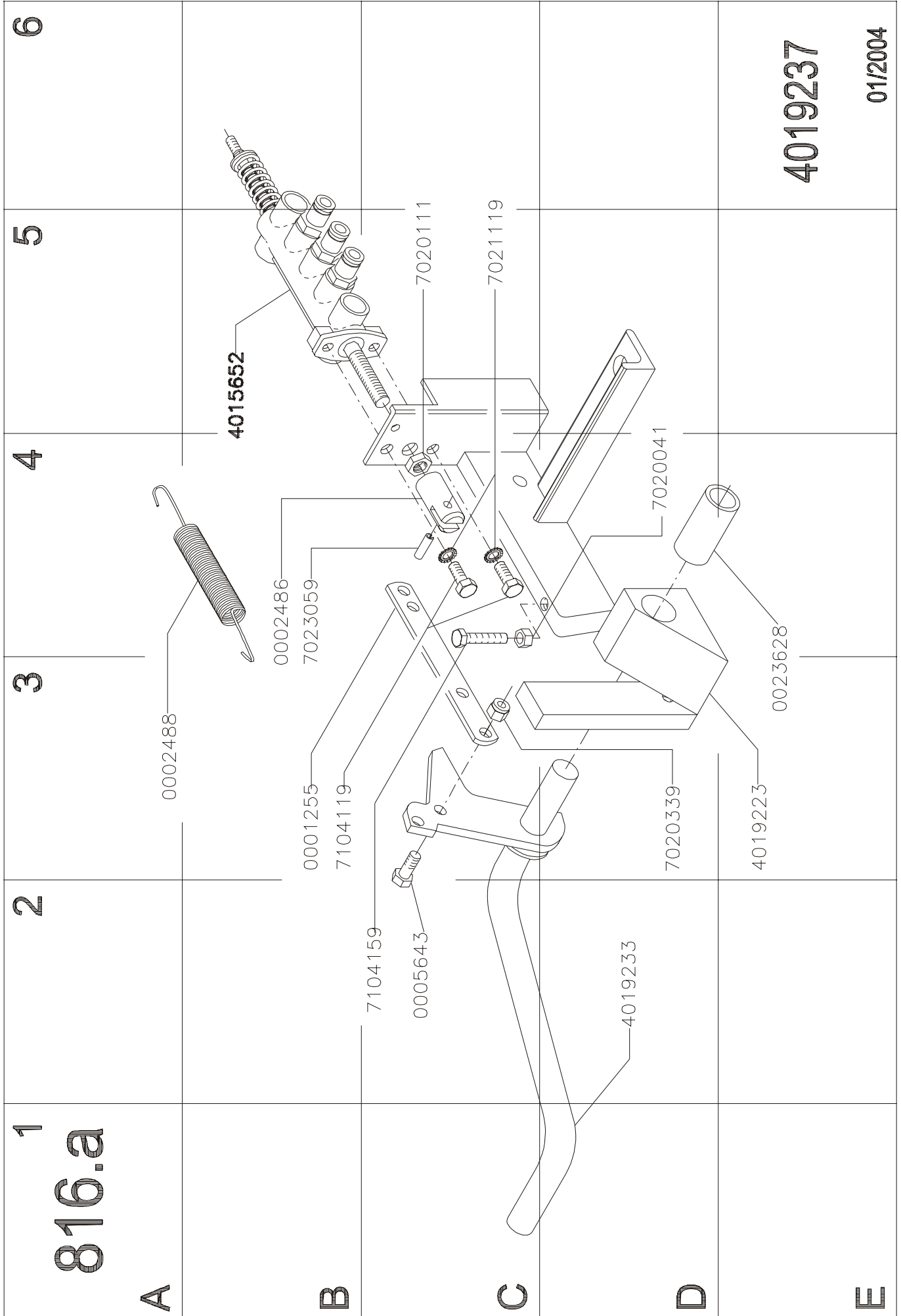

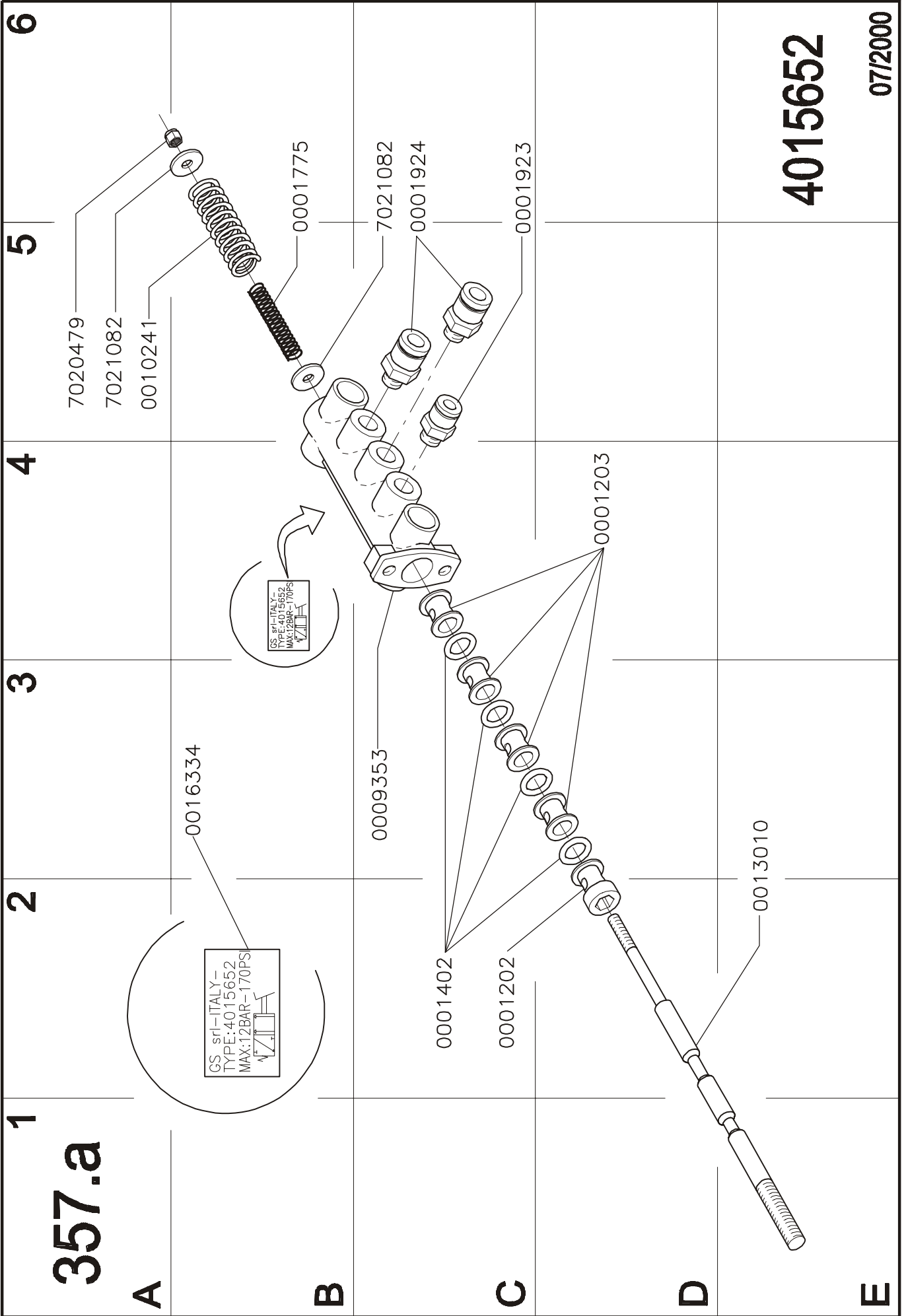

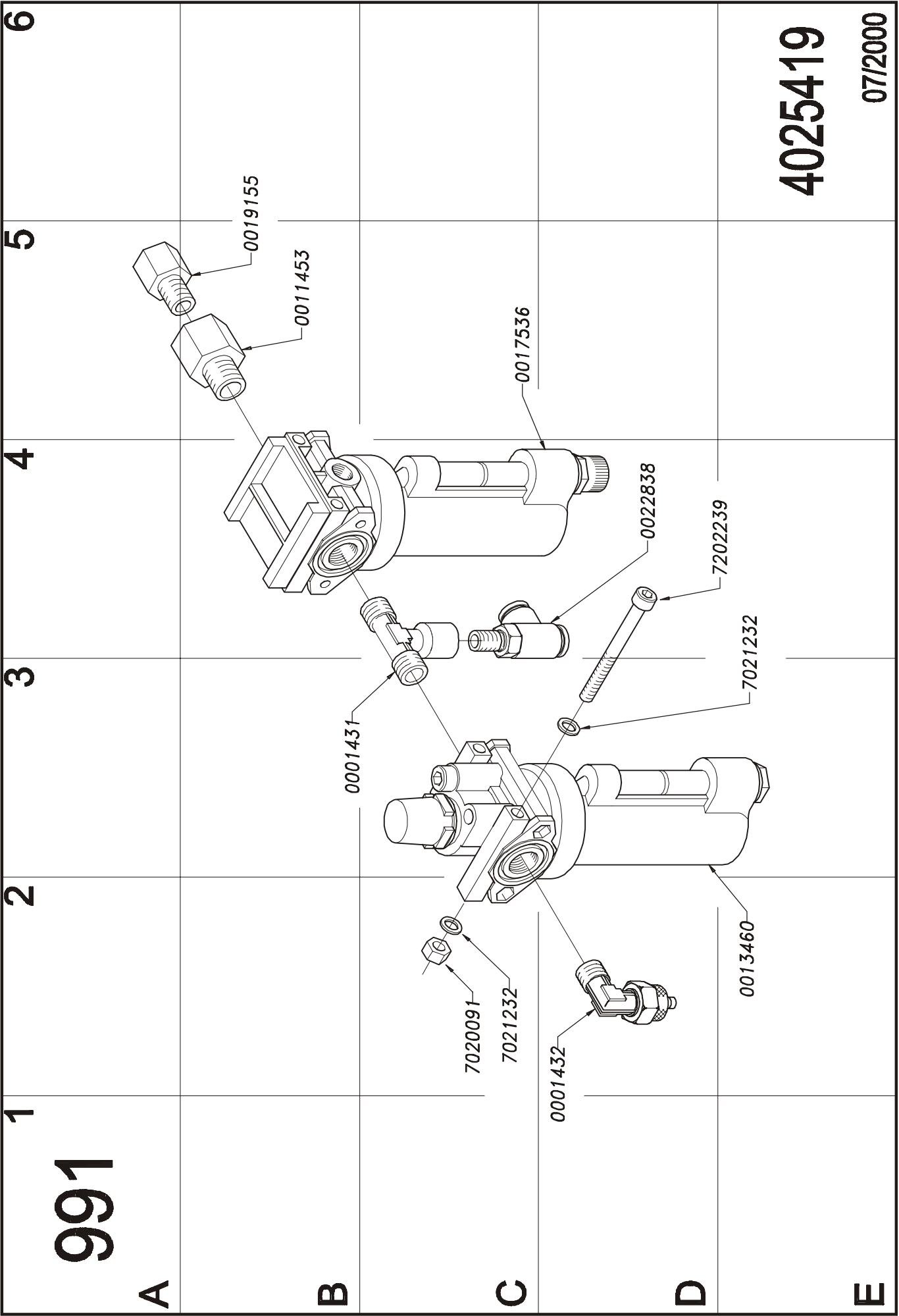

4025419

07/2000

117-c-Nov-04

1079

A

B

C

D

E

F

1

2

3

4

5

0014514

0022173

0016432

7106109

0016515

0025793

0013157

7021159
7020125

7021159
0024947
7106109

0004139

0001384

0013156

0013154

0005879
0010943
0010944

0005803

0005804

0003398

7020011

7021012

0025037

7021012

7105139

12/2001

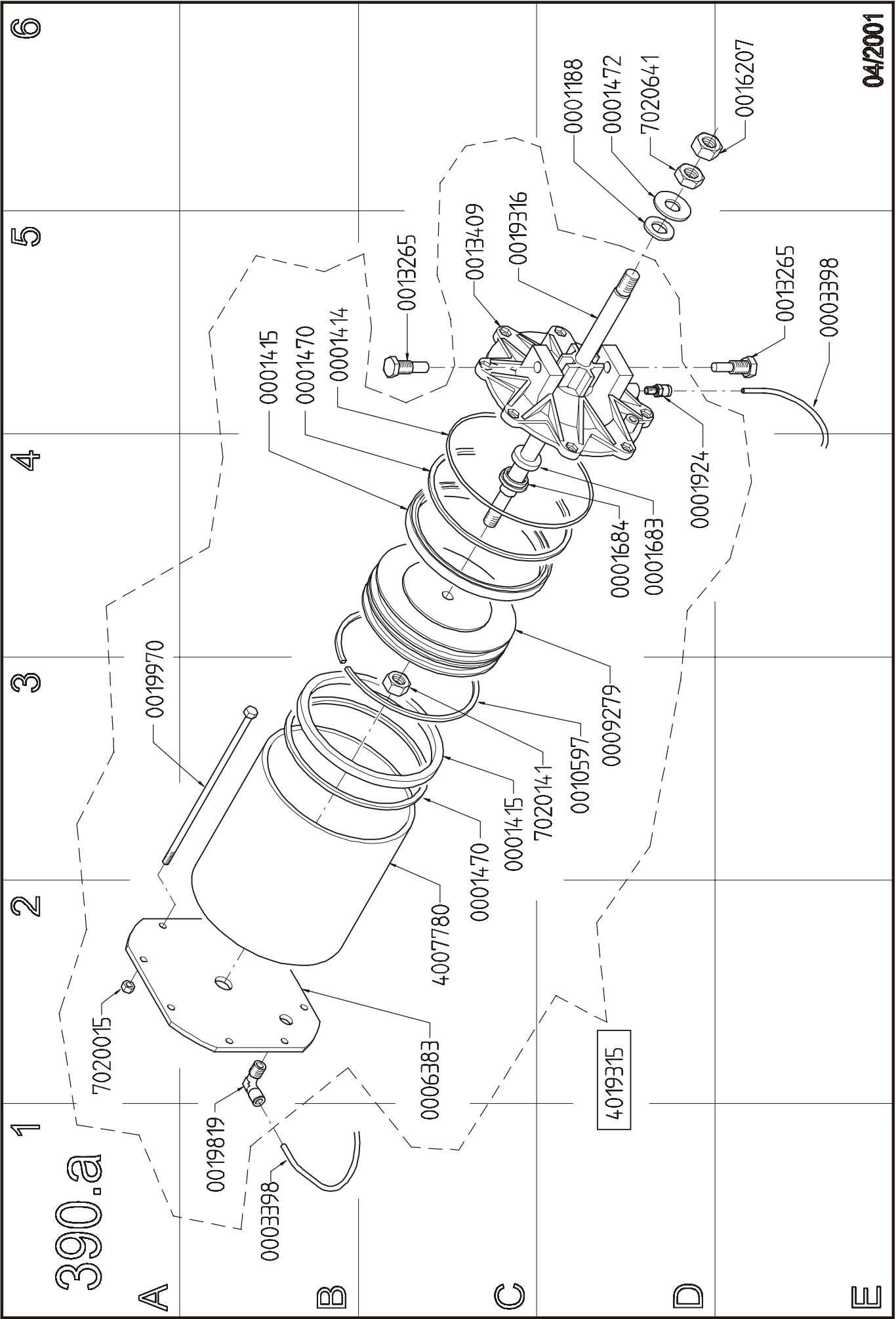

04/2001

117-c-Nov-04

1080.a

A

1

2

3

4

5

B

C

D

E

F

0001613
4016060

7803309

0024044

7205639

0017239

0026354

7021092

7021102

7020015

7020815

0002610

0001535

0014523

4026075

7105025

7021102

7021039

7020015

0027040

7105025

7021015

7021039

0006993

0001535

4025692

06/2004

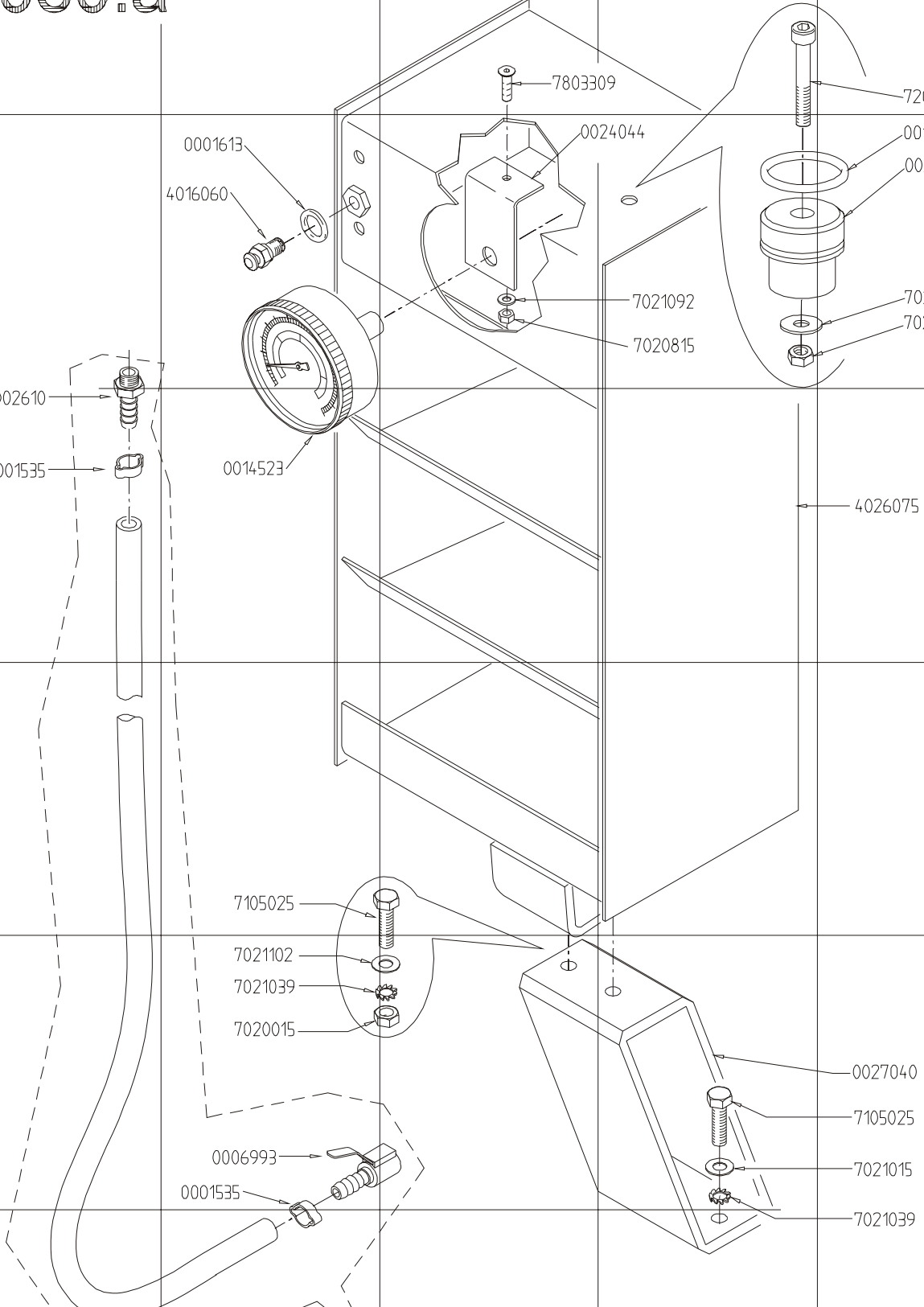

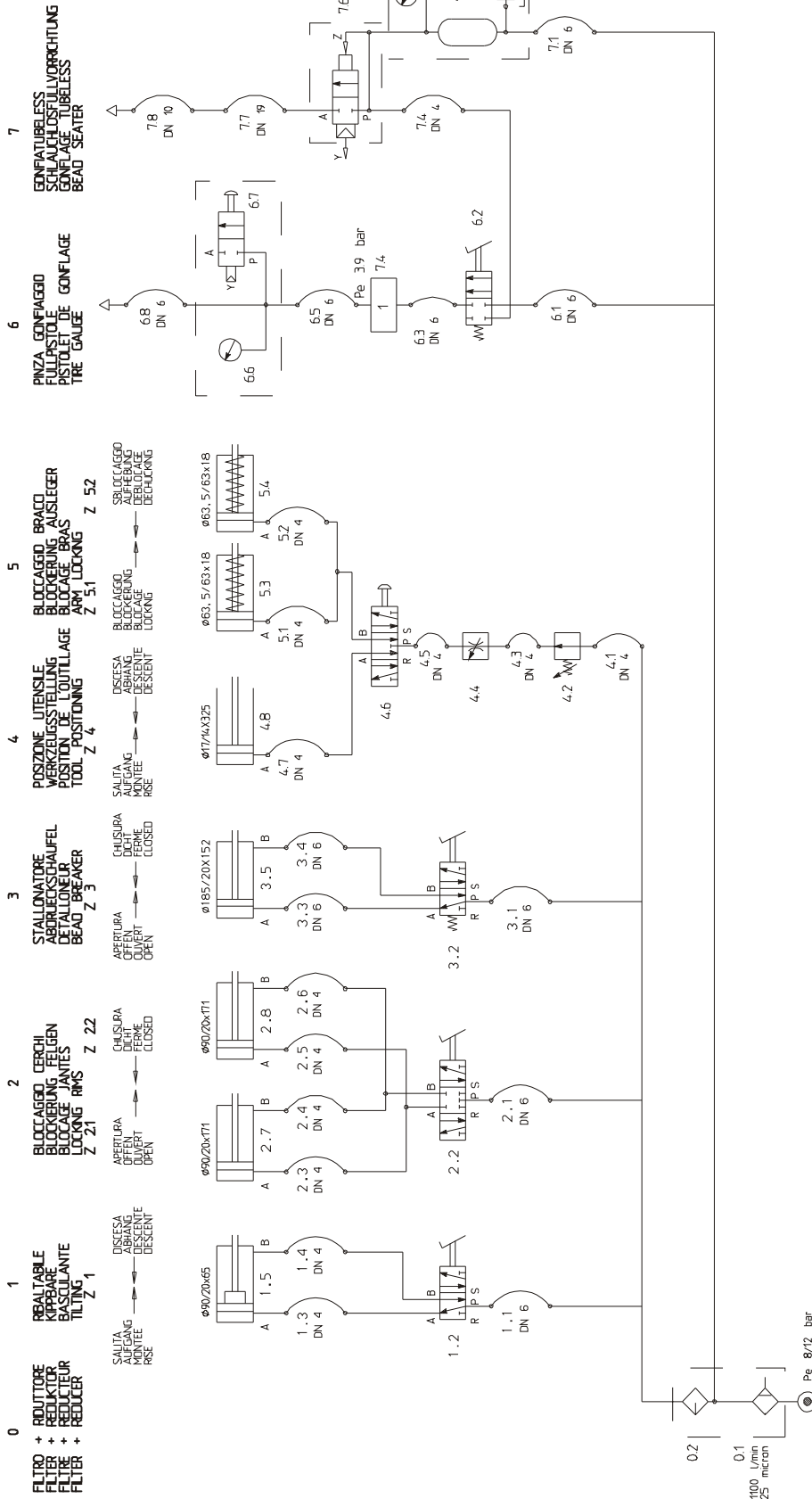

- 0 FILTRO + RIDUTTORE
FILTER + REDUKTOR
FILTRE + REDUCTEUR
- 1 RIBALTABILE
KIPPBARE
BASULANTE
- 2 BLOCCAGGIO CERCHI
BLOCKIERUNG FELGEN
BLOCCAGE JANTES
- 3 STALLONATORE
ABRIJKERSCHAUFEL
DETALLONEUR
- 4 POSIZIONE UTENSILE
WERKZEUGSSTELLUNG
POSITION DE L'OUTILLAGE
- 5 BLOCCAGGIO BRACCIO
BLOCKIERUNG AUSLEGER
BLOCCAGE BRAS
- 6 PINZA GONFIAGGIO
PISTOLET DE GONFLAGE
TIRE GAUCHE
- 7 GONFIATUBILESS
SCHLAUCHSFULLVORRICHTUNG
GONFLAGE TUBELSS

1) VALVOLA LIMITATRICE E DI CONTROLLO DELLA PRESSIONE DI GONFIAGGIO
1) INFLATING PRESSURE LIMITING AND REGISTER VALVE

GRUPPO GRUPPE GROUP	PAGINA BLATT PAGE	N° - PAGINE V. - BLATT N° - DE PAGES	CLIENTE BESTELLER CLIENT	FIRMA GEZ. SIGNATURE	MARIANI	DATA DATUM DATE	2002/09/23	VISTO GEPRÜFT TESTÉ	PAR BY	SCHEMA PNEUMATISCHEN PNEUMATIQUE SCHEMA PNEUMATIC SCHEMA	ACCUS5602	FAMIGLIA 824	CODICE CODE N°.	Zeichnungs N°. 0027819
TIPO MODELLE MODEL ACCU 5602 CODICE MACCHINA INVENTAR N°. MACHINEN N°. CODE MACHINE														
MODIFICA AENDERUNG MODIFICATION CHANGE DATA DATE DATE														

Revision C			Differences on previous version.
OPERATOR'S MANUAL:			
- Two position jaw updating.			
- Replaced pict. 1.5-1 and 3.0-2.			
- From the chapter 4.0 all pictures ref. number has been updated.			
SPARE PARTS:			
- Tables (Exploded view)			
OLD	UPDATED	ADDED	
- 816	- 816.a		
- 1077	- 1077.a		
- 1080	- 1080.a		
- 1084	- 1084.a		
- 1202.a	- 1202.b		
- 1203	- 1203.a		
- 1204	- 1204.a		

USA

Accu Industries, Inc

P.O. Box 15540 / Richmond, Va.
23227

11126 Air Park Road / Ashland,
Va. 23005

phone: 804.798.8922

toll free: 1.800.551.2228

fax: 804.798.6742



Notice: The information contained in this document is subject to change without notice. **ACCU-TURN Company** shall not be liable for errors contained herein or for incidental consequential damages in connection with furnishings, performance, or use of this material.

This document contains proprietary information which is protected by copyright and patents. All rights are reserved. No part of this document may be photocopied, reproduced, or translated without prior written consent of **ACCU-TURN Company**.

Updated...11/2004...copyright 2004 - gft...**Rev.C**

Printed in the USA



Accu Industries, Inc.

P.O. BOX 15540 / RICHMOND, VA 23227
11126 AIR PARK ROAD / ASHLAND, VA 23005
804-798-8922 FAX 804-798-6742
www.accu-turn.com