

Accu Industries, Inc.®

ACCU 4560

**ELECTRIC-HYDRAULIC TIRE CHANGER
FOR MEDIUM AND LARGE SIZE TIRES**

OPERATOR'S MANUAL
SPARE PARTS EXPLODED VIEWS

TABLE OF CONTENTS

1.0 INTRODUCTION	Page 4
1.1 USE LIMITATIONS	Page 4
1.2 NOTICE	Page 4
1.3 GENERAL SAFETY INSTRUCTIONS	Page 4
1.4 NOMENCLATURE	Page 4
1.5 SPECIFICATIONS	Page 5
1.6 DIMENSIONS OF THE MACHINE	Page 5
1.7 STANDARD ACCESSORIES	Page 5
1.8 ACCESSORIES ON REQUEST	Page 6
1.9 SAFETY PRECAUTIONS	Page 7
1.10 SAFETY DEVICES	Page 7
2.0 CARRIAGE INSTRUCTIONS	Page 8
2.1 UNCRATING INSTRUCTIONS	Page 8
2.2 INSTALLATION AREA	Page 8
3.0 INSTALLATION INSTRUCTIONS	Page 9
3.1 ELECTRIC INSTALLATION	Page 9
3.2 MOTOR ROTATION CHECK	Page 9
4.0 CONTROLS	Page 10
5.0 MOUNTING AND DEMOUNTING - GENERAL PRECAUTIONS	Page 11
5.1 LOCKING RIMS	Page 12
5.2 DEMOUNTING TUBELESS TRUCK TIRES (UP TO 13" WIDE)	Page 13
5.3 MOUNTING TUBELESS TRUCK TIRES (UP TO 13" WIDE)	Page 15
5.4 DEMOUNTING DUPLEX AND SUPERSINGLE TUBELESS TRUCK TIRES (OVER 13" WIDE)	Page 17
5.5 MOUNTING DUPLEX AND SUPERSINGLE TUBELESS TRUCK TIRES (OVER 13" WIDE)	Page 18
5.6 DEMOUNTING TIRES FROM MULTI-PIECE RIM/WHEEL ASSEMBLIES	Page 19
5.7 MOUNTING TIRES ONTO MULTI-PIECE RIM/WHEEL ASSEMBLIES	Page 20
5.8 DEMOUNTING TRACTOR AND O.T.R. WHEELS WITH ONE-PIECE RIMS	Page 21
5.9 MOUNTING TRACTOR AND O.T.R. WHEELS ON ONE-PIECE RIMS	Page 22
6.0 MAINTENANCE	Page 23
7.0 MOVING THE MACHINE	Page 24
8.0 PUTTING THE MACHINE OUT OF SERVICE	Page 24
9.0 SCRAPPING THE MACHINE	Page 24
10.0 TROUBLE SHOOTING	Page 25

1.0 INTRODUCTION

Congratulations on purchasing the ACCU Model 4560 electric-hydraulic tire changer.

This tire changer is designed for ease of operation, safe handling of rims, reliability and speed.

With a minimum of maintenance and care, your tire changer will provide many years of trouble-free operation.

Instructions on use, maintenance and operational requirements of the machine are covered in this manual.

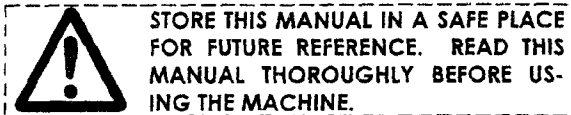

1.1 USE LIMITATIONS

The ACCU Model 4560 model tire changer is intended to be used as a device to demount and mount tubeless truck tires with the following specifications:

Maximum tire diameter: 2300 mm (90" 1/2)
Maximum tire width: 1100 mm (43")

This device shall be used in the application for which it is specifically designed.

Any other use shall be considered as improper, thus not reasonable.

In particular, this device is not suitable to inflate tires. Inflation of tires shall be carried out in an approved inflation safety cage.

The manufacturer shall not be considered liable for possible damage caused by improper, wrong or non-reasonable use.

1.2 NOTICE

This manual is a part of the product. Read carefully the warnings and instructions of this manual since they provide important information concerning safety and maintenance.

1.3 GENERAL SAFETY INSTRUCTIONS

THE USE OF THIS DEVICE IS ALLOWED ONLY TO PERSONNEL DULY TRAINED BY AN AUTHORIZED ACCU DEALER.

ANY MISUSE OR MODIFICATION OF THIS DEVICE OR OF ITS PARTS OR COMPONENTS NOT PREVIOUSLY AUTHORIZED BY THE MANUFACTURER WAIVE THE MANUFACTURER FROM ANY DAMAGE CONSEQUENT OR RELATED TO THE ABOVE MENTIONED MISUSES.

REMOVING OR BYPASSING SAFETY DEVICES OR WARNING LABELS OF THE MACHINE IS A VIOLATION OF THE SAFETY REGULATIONS.

THE USE OF THIS DEVICE IS ALLOWED ONLY IN LOCATIONS WITH NO EXPLOSION OR FIRE HAZARD.

THIS EQUIPMENT IS DESIGNED TO RECEIVE ORIGINAL SPARE PARTS AND ACCESSORIES ONLY.

THE INSTALLATION SHALL BE CARRIED OUT ONLY BY QUALIFIED PERSONNEL AND WITHIN THE SCOPE OF THE INSTRUCTIONS PROVIDED IN THIS MANUAL.

CHECK FOR POSSIBLE DANGEROUS CONDITIONS DURING THE OPERATION OF THE MACHINE. IN SUCH A CASE STOP THE MACHINE IMMEDIATELY. IN CASE A DEFECTIVE FUNCTIONING CONDITION IS DETECTED, STOP USING THE MACHINE AND CALL THE AUTHORIZED ACCU DISTRIBUTOR FOR ASSISTANCE.



ALL ELECTRICAL CONNECTIONS SHALL BE PERFORMED BY A LICENCED TECHNICIAN. ALL SERVICE MUST BE PERFORMED BY AN AUTHORIZED SERVICE TECHNICIAN.

1.4 NOMENCLATURE

Before installing and using the tire changer it is suggested that you become familiar with the nomenclature of the machine's components (Fig.1).

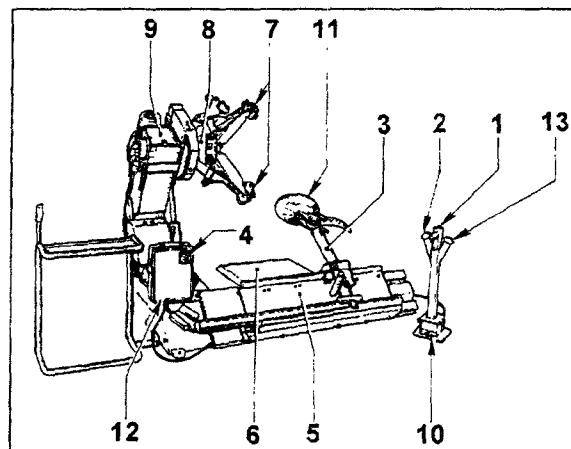

Fig. 1

1. 8 position switch
2. Chuck switch
3. Toolholder arm
4. Main switch
5. Toolholder carriage
6. Footboard
7. Jaws
8. Self-centering chuck
9. Chuck arm
10. Chuck rotation control pedal
11. Mount/demount tool
12. Electric cabinet
13. Toolholder arm switch

1.5 SPECIFICATIONS

Electric-hydraulic tire changer for tubeless truck wheels.

Weight with standard acc.	945 kg(2079 lbs)
Electric specifications	400VAC,3ph,50-60Hz,9.5A
Hydraulic motor power	1.5 kW (2 HP)
Chuck rotation motor power	1.5-2.2 kW (2-3 HP)
Chuck capacity	14" - 56"
Max. tire diameter	2300 mm (90"1/2)
Max. tire width	1100 mm (43")
Max. chuck torque	3100 Nm(2268 ftlbs)
Clamping power	60kN
Chuck rotation speed	4-8 rpm
Acoustic pressure	<70dBA

1.6 DIMENSIONS OF THE MACHINE

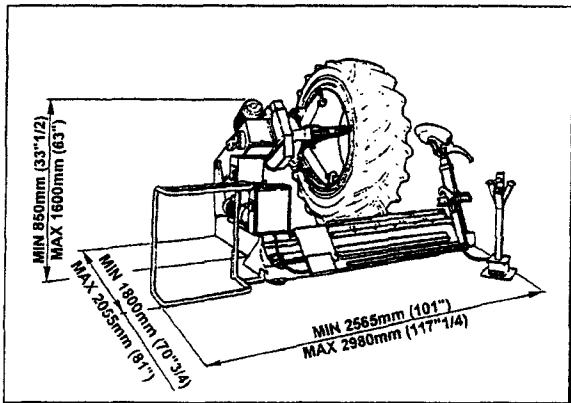

Fig. 2

1.7 STANDARD ACCESSORIES

- #0001418 Shore tire tool
- #4004461 Long tire tool
- #4002354 Bead pushing lever

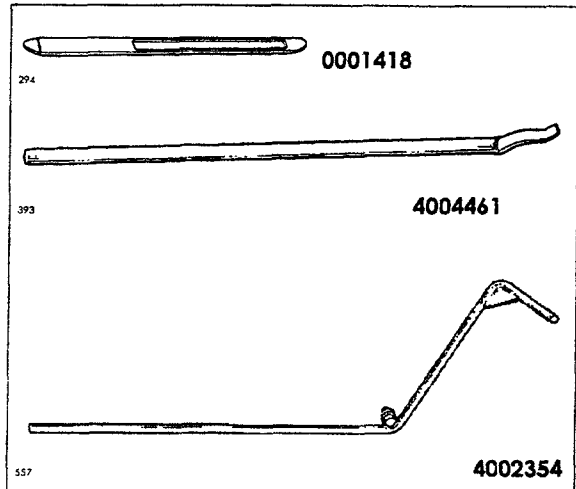

Fig.3

#4009472 Mounting clamp (Fig.4).

To hold the bead when mounting tires on steel rims. Instructions for use is in section 5.3.

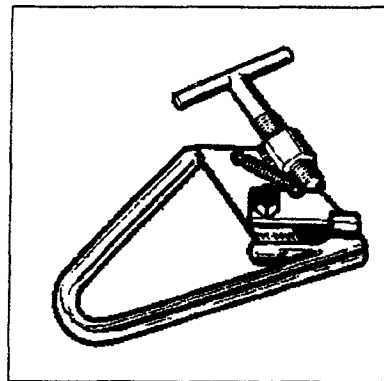

Fig.4

1.8 ACCESSORIES ON REQUEST

#4021852 Clamp for light-alloy rims (Fig.5).
 To hold the bead when mounting tires on light-alloy rims. Instructions for use is in section 5.3.

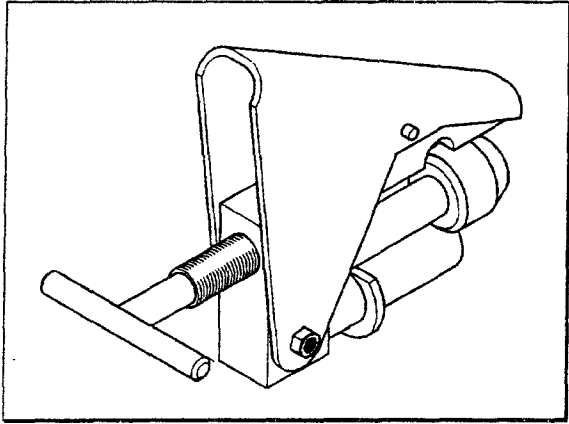

Fig.5

#4007611 O.T.R. Clamp (Fig.6)
 Useful when breaking the bead from the rim on multi-piece wheels (O.T.R.). Instructions for use is in section 5.6.

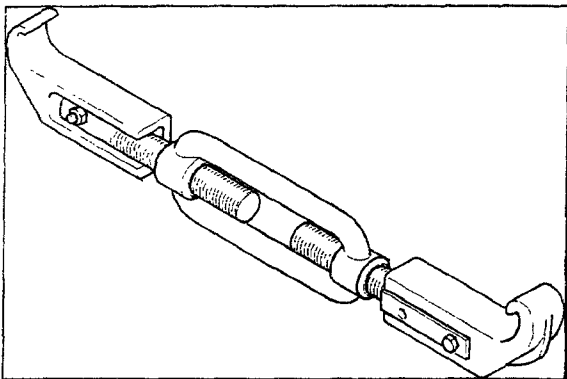

Fig.6

#4008257 Protectors for alloy rims (Fig.7).
 Suitable for rims with a center hole of 220 and 280 mm.

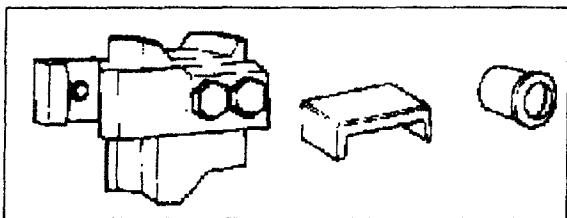

Fig.7

#4008264 Protectors for alloy rims (Fig.8)
 Suitable for rims with a center hole of 280 mm only.

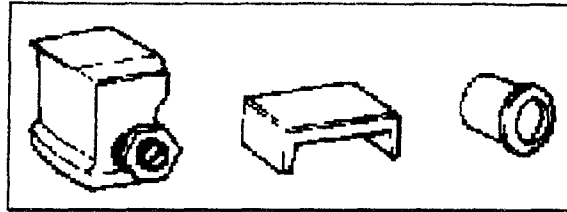

Fig.8

#4014974 Tubeless roller (Fig.9).
 Facilitates mounting and dismounting tubeless tires up to 13" wide.

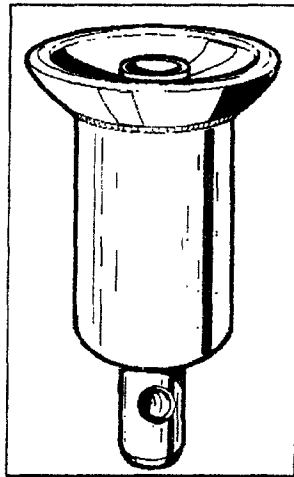

Fig.9

#4019161 Extensions for 56" (Fig.9/A).
 Necessary when clamping rims without flange and with a diameter exceeding 44".

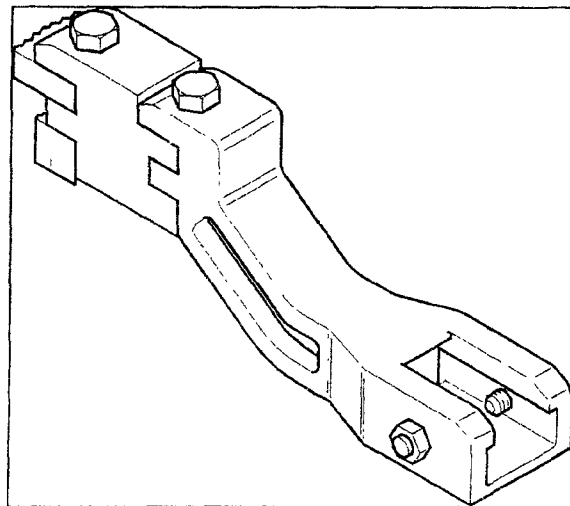

Fig.9/A

1.9 SAFETY PRECAUTIONS

A. BEFORE SERVICING ANY TIRES, WHEELS OR RIMS ALL PERSONNEL SHOULD RECEIVE THOROUGH TRAINING FOR THE PROPER SERVICING OF TRUCK TIRES, WHEELS AND RIMS. CONSULT WITH YOUR LOCAL CITY, COUNTRY STATE, AND NATIONAL SAFETY AND HEALTH ADMISTRATIONS TO RECEIVE CLARIFICATION OF ANY PUBLICATIONS AVAILABLE GOVERNING THIS SERIOUS MATTER.

B. DURING THE USE AND MAINTENANCE OF THE MACHINE IT IS MANDATORY TO COMPLY WITH ALL LAWS AND REGULATIONS FOR ACCIDENT PREVENTION.

C. THE ELECTRIC POWER SOURCE MUST HAVE A GROUND CABLE AND THE GROUND CABLE OF THE MACHINE (YELLOW WITH GREEN) MUST BE CONNECTED TO THE GROUND CABLE OF THE POWER SOURCE.

D. BEFORE ANY MAINTENANCE OR REPAIRS ARE ACCOMPLISHED THE MACHINE MUST BE DISCONNECTED FROM THE ELECTRIC SUPPLY.

E. NEVER WEAR TIES, CHAINS OR OTHER LOOSE ARTICLES WHEN USING, MAINTAINING OR REPAIRING THE MACHINE. LONG HAIR IS ALSO DANGEROUS AND SHOULD BE KEPT UNDER A HAT. THE USER MUST WEAR PROPER SAFETY ATTIRE, I.E. GLOVES, SAFETY SHOES AND GLASSES.

F. MAINTAIN ALL ELECTRIC CORDS IN GOOD REPAIR.

G. KEEP SAFETY FEATURES IN PLACE AND IN WORKING ORDER.

H. KEEP WORKING AREA CLEAN. CLUTTERED AREAS INVITE ACCIDENTS.

I. AVOID DANGEROUS ENVIRONMENTS. DON'T USE POWER TOOLS OR ELECTRICAL EQUIPMENT IN DAMP OR WET LOCATIONS, OR EXPOSE THEM TO RAIN.

L. NOBODY SHOULD BE ALLOWED TO STAND NEXT TO THE WHEEL, WHEN MOUNTING/DEMOUNTING A TIRE OR CLAMPING A WHEEL.

M. KEEP THE WORK AREA WELL LIGHTED.

N. PROPERLY ATTACH THE MACHINE TO THE FLOOR.

1.10 SAFETY DEVICES

This machine has several protectors to prevent compression or crushing hazards.

There is a micro-switch protection under the chuck arm to prevent compression.

The rotation speed of the chuck has been limited to a maximum of 8 rpm to prevent dragging or entrapping hazards.

There is an emergency button on the portable control unit.

2.0 CARRIAGE INSTRUCTIONS

The machine is crated in a wooden box of appropriate strength.
The box is mounted on a pallet.
Handling of the machine must be performed with an appropriate lifting device (fork lift) (Fig.10).

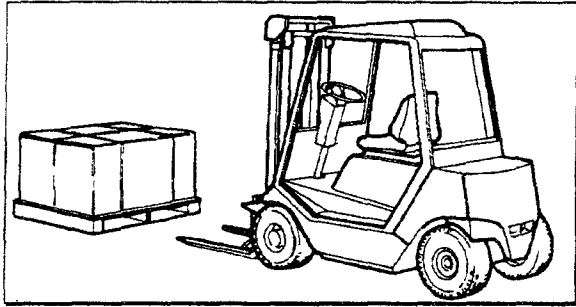

Fig.10

2.1 UNCRATING INSTRUCTIONS

Uncrate the machine paying attention when removing the nails or during any other operation which may be hazardous.
After removing the crate, check for any visible damage to the machine and its components.
If in doubt, call qualified personnel for assistance.
The packing materials (plastic bags, polystyrene, nails, screws, wood etc.) must be properly disposed of.
Place the above-mentioned materials into a trash container and dispose per local regulations.

 **ALWAYS WEAR GLOVES WHEN UNCRATING THE MACHINE TO PREVENT SCRATCHES OR ABRASIONS DUE TO THE CONTACT WITH PACKING MATERIALS.**

2.2 INSTALLATION AREA

Install the machine in a covered and dry area.
The installation of the machine requires a free space of at least cm 500x500 (16'5"x16'5") (Fig.11).

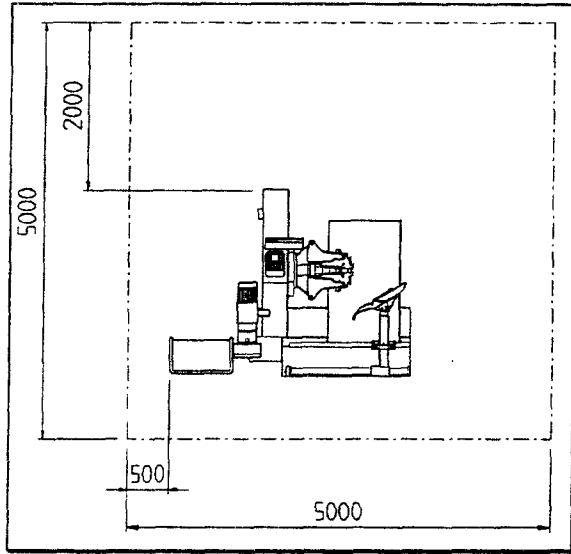

Fig.11

Make sure that from the operating position the user can see all of the machine and the surrounding area.
The operator shall forbid, in such an area, the presence of non-authorized persons and of objects which may create possible hazards.
The machine shall be installed on a horizontal floor, preferably even. Do not install the machine on a sinking or irregular floor.
In case the machine is installed on a raised floor or on a service vehicle, the floor must have a capacity of at least 15000 N/m² (1500 kg/m² or 330 lbs x sqft).

The machine must be secured to the floor through the holes provided in the cabinet. Expansion screws 12x120 mm (or bolts 12x80mm) shall be used.
Drill 12 mm holes in the floor flush with the holes provided in the cabinet.
Place the nogs into the holes drilled in the floor and move the machine so that the holes of the cabinet are flush with the holes in the floor.
Tighten the screws to 70 Nm (51 ft·lb).

3.0 INSTALLATION INSTRUCTIONS

To install the machine proceed as follows:

- A. Before raising the machine, ensure that the chuck is completely closed, that the chuck arm is lowered and the toolholder carriage is in all the way in Fig.12.

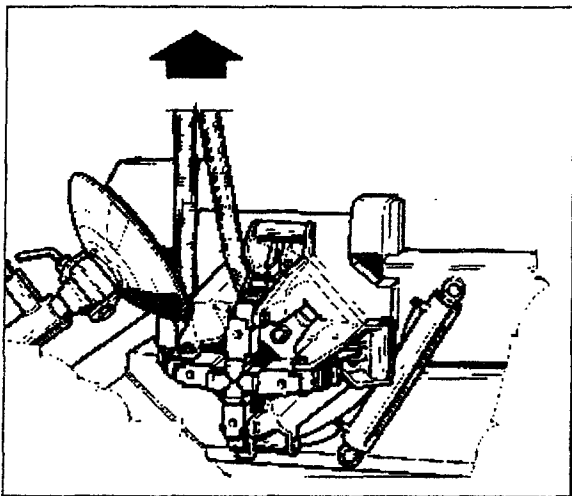



Fig.12

- B. Remove the screws that secure the machine to the pallet.
Lift the machine only with the two lifting lugs with a belt or rope of appropriate length and strength (300 cm - 10') (Fig.12).

 **DO NOT SWING THE MACHINE WHEN LIFTED.
DO NOT CUT THE REMOTE UNIT CORD WHEN LOWERING THE MACHINE TO THE GROUND.**

3.1 ELECTRIC INSTALLATION

 **ALL ELECTRICAL CONNECTIONS SHALL BE PERFORMED BY A LICENCED TECHNICIAN. ALL SERVICE MUST BE PERFORMED BY AN AUTHORIZED SERVICE TECHNICIAN.**

Check on the plate of the machine that the electrical specifications of the power source are the same as the machine.

The machine uses 400VAC, 50 Hz, 3Ph, 9.5 Amp. Electrical specifications are clearly marked on a label at the end of the electric cord.

Before connecting the machine to the power source, check that the power supply has an efficient grounding system.

Connect the electric cord of the machine with a homologated plug.

There should be less than 1 Ω between the ground pin and earth ground.

NOTE:

The outlet installation must be verified by a licensed electrician before connecting the tire changer.

NOTE:

The yellow with green wire in the cord is the grounding wire.

Never connect the grounding wire to a live terminal.

Check that the power supply has an automatic circuit breaker with a differential circuit set at 30 mA.

The electric motor operates in a wide voltage range (plus 10% - minus 7%) and frequency range (50 or 60 cycles) and has a class of insulation suitable for hot and moist climates.

3.2 MOTOR ROTATION CHECK

Once the machine is hooked-up, turn the machine on using the ON/OFF switch.

Ensure that the rotation direction of the pump is the same as indicated by the arrow on the motor cover.

If not, reverse any two phase cables on the plug (i.e. reverse the brown and the blue cable).

 **ANY DAMAGE CAUSED BY THE NON APPLICATION OF THE ABOVE INSTRUCTIONS SHALL NOT BE DEBITED TO THE MANUFACTURER AND WILL VOID THE WARRANTY.**

4.0 CONTROLS

Before operating the machine ensure that you have well understood the operation and function of all the controls.

1. To turn the machine on, rotate the ON/OFF switch to position 1 and press the reset button: the pump motor starts turning and remains in operation until the machine is turned off. The power required is minimum when the hydraulic cylinders are not in use.

NOTE:

IT IS SUGGESTED TO TURN THE MACHINE OFF AFTER EVERY MOUNTING OR DEMOUNTING OPERATION, IF THE TIME BEFORE THE NEXT OPERATION IS LONGER THAN 5 MINUTES.

2. Press the chuck rotation pedal to the right: the chuck rotates clockwise. Press the other pedal: the chuck rotates counter clockwise.
3. Operate the control (#1 Fig.13) to position A: the chuck arm moves upwards. Operate the control (#1 Fig.13) to position B: the chuck arm moves downwards.
4. Operate the control (#1 Fig.13) to position C: the toolholder carriage moves to the right. Operate the control (#1 Fig.13) to position D: the toolholder carriage moves to the left.

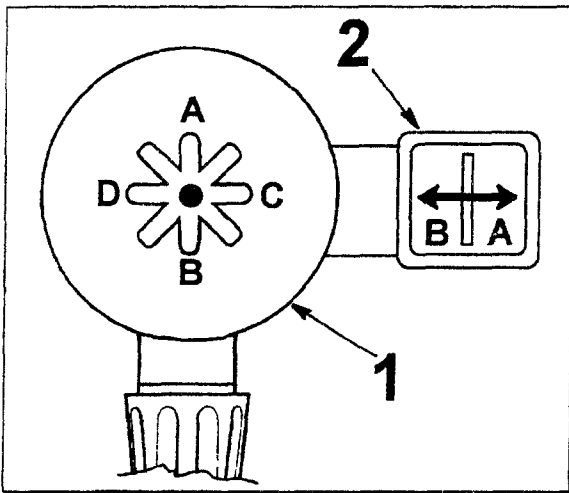

Fig.13

5. Operate the control (#2 Fig.13) to position A: the toolholder arm moves to the right. Turn the switch to position B: the toolholder arm moves to the left.

6. By operating the controls in one of the diagonal positions, the two adjacent movements are achieved simultaneously. This operation affords considerable time saving in the intermediate operations, but requires a little practice.

NOTE:

IF ONE OF THE TWO HYDRAULIC MOVEMENTS REACHES THE END OF ITS COURSE, THE SPEED OF THE OTHER MOVEMENT IS APPRECIABLY REDUCED: INTERRUPT THE CONTROL ENGAGED AND OPERATE ONLY THE DESIRED MOVEMENT IN ORDER TO GET NORMAL OPERATING SPEED.

7. To lift the toolholder arm, depress the pedal (#1 Fig. 14) and hold handle (#2 Fig.14). The arm is balanced by a spring-loaded mechanism and the effort required is minimum. When locking the arm into working position be sure to use enough force to ensure a proper lock. The heavy metal construction can easily absorb the force.

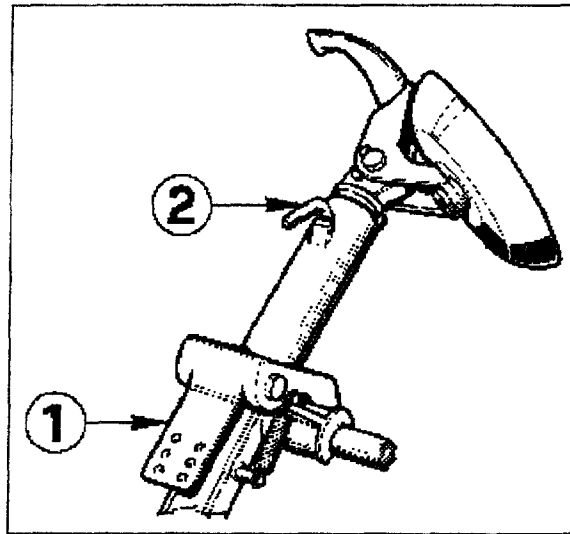
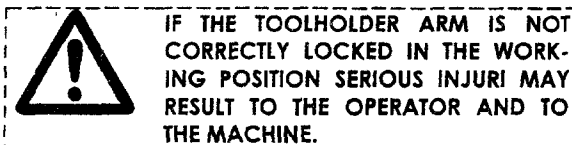

Fig.14



8. To turn the tool remove pin (#2 Fig.14).



BE SURE THAT THE LOCK PIN IS PROPERLY FITTED.

9. To open and close the chuck, operate the appropriate control (Fig.15).

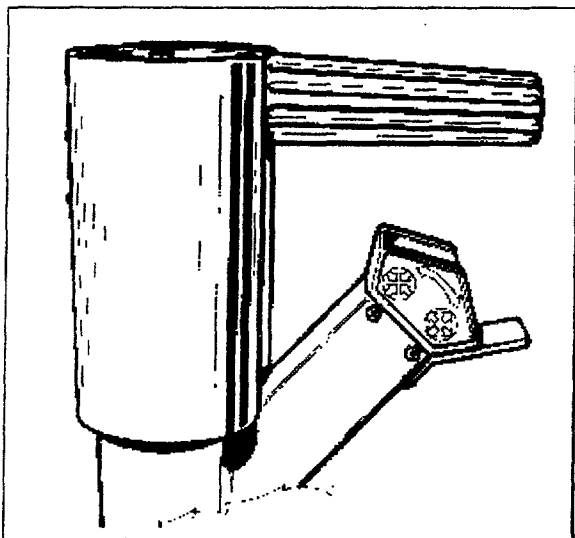

Fig.15



WHEN OPENING THE CHUCK ENSURE THAT THE JAWS DO NOT HIT OTHER PARTS OF THE MACHINE.

5.0 MOUNTING AND DEMOUNTING-GENERAL PRECAUTIONS



BEFORE MOUNTING A TIRE ON A RIM, PAY ATTENTION TO THE FOLLOWING:

- A. THE RIM AND ALL ITS PARTS MUST BE CLEAN AND IN GOOD CONDITION: IF NECESSARY CLEAN AND PAINT IT AFTER REMOVING ALL WHEEL-WEIGHTS INCLUDING TAPE WEIGHTS INSIDE THE RIM.
- B. THE TIRE MUST BE CLEAN AND DRY, WITHOUT ANY DAMAGE TO THE BEAD AND THE CARCASS.
- C. REPLACE THE RUBBER VALVE STEM WITH A NEW ONE OR REPLACE THE 'O' RING IF THE VALVE STEM IS MADE OF METAL.
- D. IF THE TIRE REQUIRES A TUBE OR A FLAP, MAKE SURE THE TUBE IS DRY AND IN GOOD CONDITION.
- E. LUBRICATION IS NECESSARY TO MOUNT THE TIRE CORRECTLY AND GET A PROPER CENTERING. BE SURE YOU ARE USING APPROVED LUBRICANT ONLY.
- F. MAKE SURE THE TIRE IS THE CORRECT SIZE FOR THE RIM.

5.1 LOCKING RIMS

Lift the toolholder arm and move the toolholder carriage all the way out.
 Put the wheel in vertically and roll it on the footboard.
 Be sure to use alloy adapters when applicable.

ATTENTION!
 THE DROP CENTER OF THE RIM (WHEN IT EXISTS) MUST BE KEPT TOWARDS THE OUTSIDE OF THE MACHINE (Fig.16).

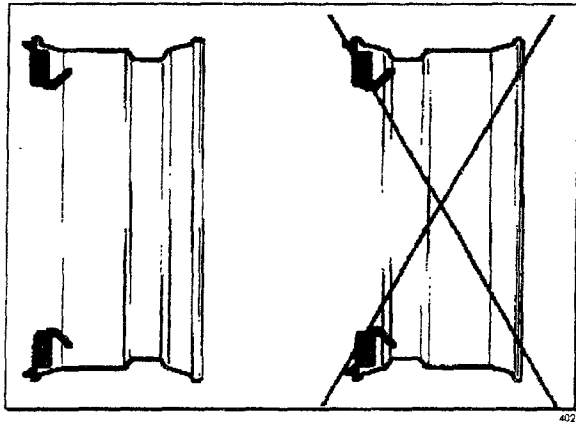

Fig.16

IF THE WHEEL IS VERY HEAVY BE SURE TO USE A SUITABLE EXTERNAL LIFTING DEVICE (I.E. FORK LIFT, CRANE ETC.)

Close the jaws of the chuck and move the chuck approximately to the center of the rim. Move the footboard toward the chuck and move the chuck up-down while opening the chuck arms until the rim is clamped properly (Fig.17).

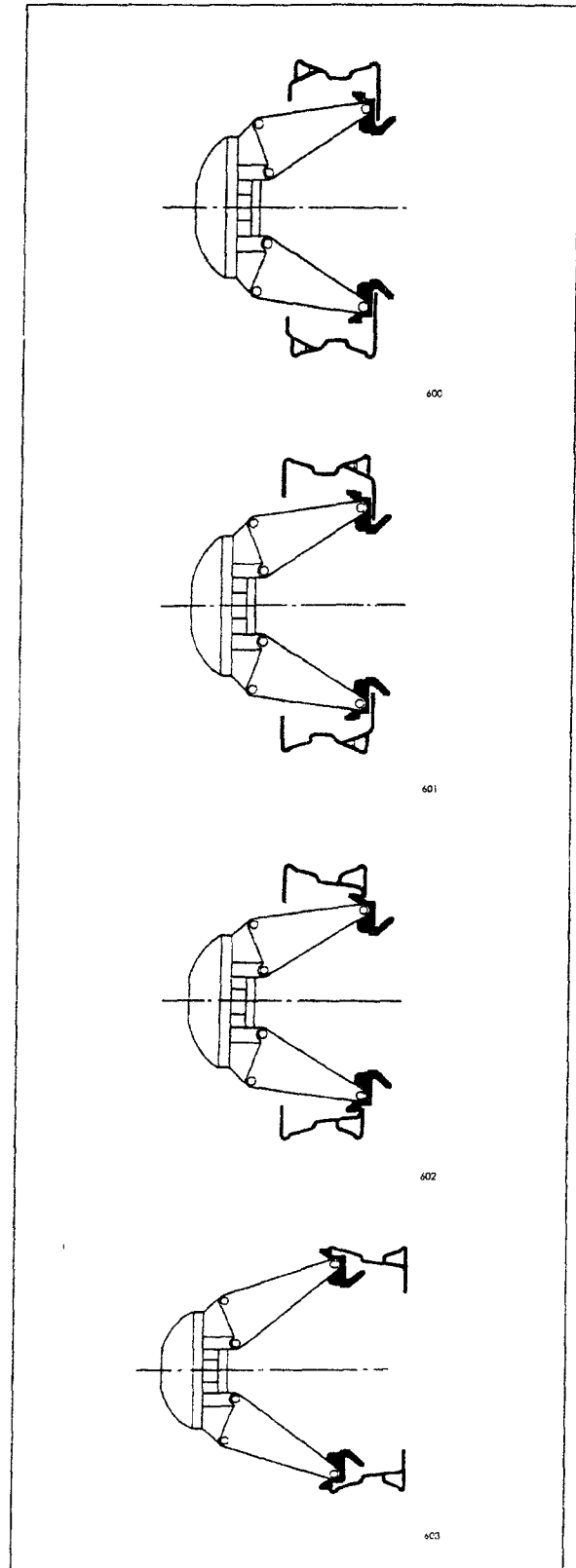

Fig.17

**5.2 DEMOUNTING TUBELESS TRUCK TIRES
(UP TO 13" WIDE)**

The tubeless truck tires are mounted on drop-center rims with a conical base. It is possible to demount these tires simply by pressure, with a proper lubrication (Fig.18).

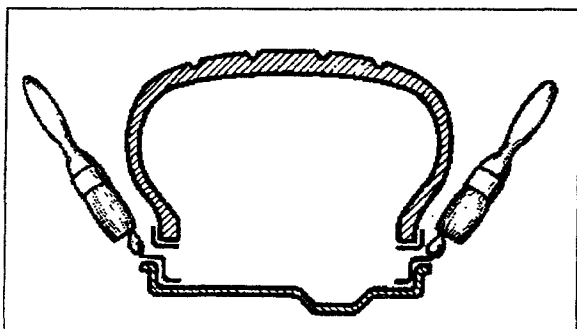

Fig.18

1. Remove all wheel-weights from the rim. Remove the valve stem or core and deflate the tire.
2. Position the bead breaker disc or tubeless roller (option) as shown in Fig.19, Fig.20.

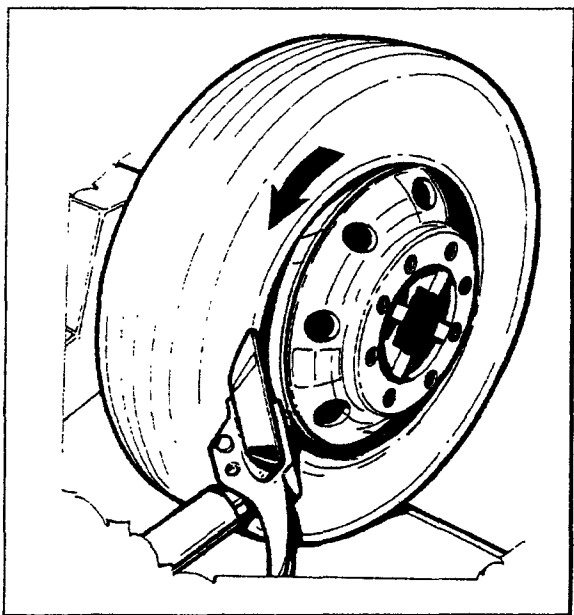

Fig.19

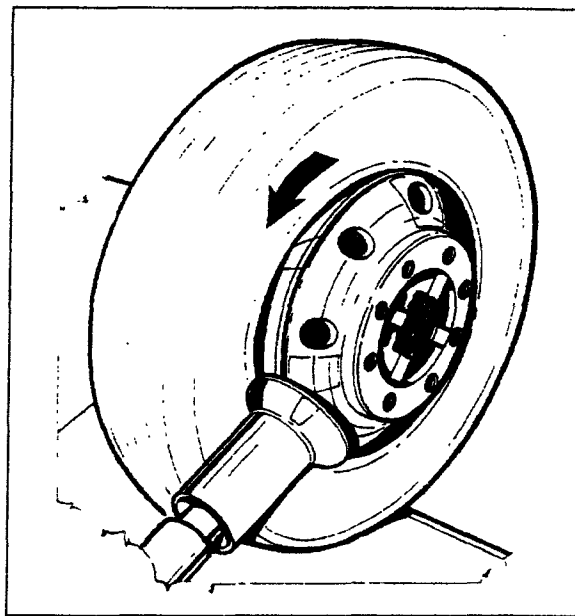

Fig.20

3. Lift or lower the chuck so that the bead breaker disc or tubeless roller remains close to the rim edge. Turn the chuck counter-clockwise and at the same time shift the toolholder carriage step-step toward the inside to demount the tire. Continue to turn the chuck and lubricate the bead and the rim liberally with an approved lubricant.

USE ONLY SPECIFIC LUBRICANTS FOR TIRES AND WHEELS. APPROVED LUBRICANTS DO NOT CONTAIN WATER, PETROLEUM PRODUCTS/HYDROCARBONS OR SILICONE.

4. Raise the toolholder arm to the rest position.
5. Move the toolholder arm all the way in. Lower the arm and secure. Bring the tool in contact with the inner bead.
6. Break the inner bead as described in point #3 above.

7. Continue rotating the chuck, moving toolholder carriage towards the outside until the beads are demounted from the rim (Fig.21 and Fig.22)

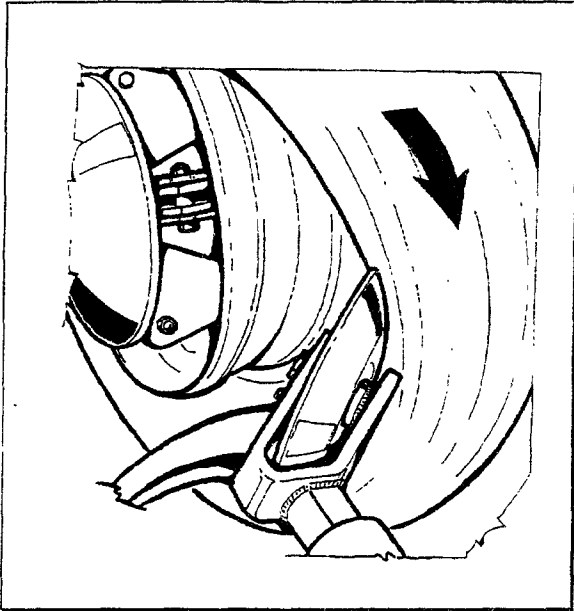

Fig.21

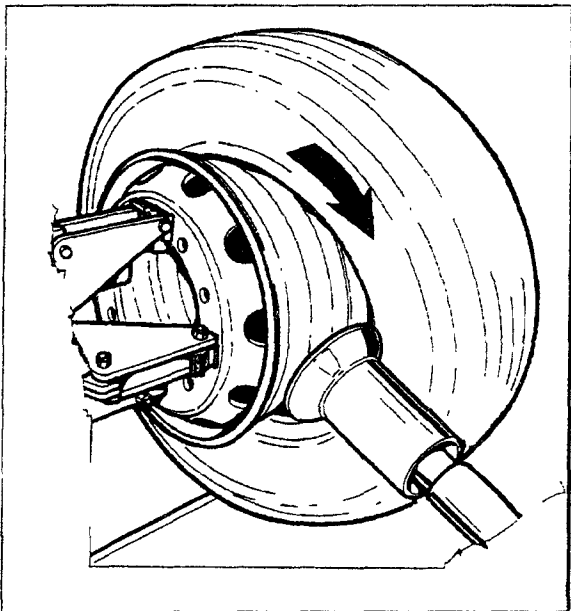
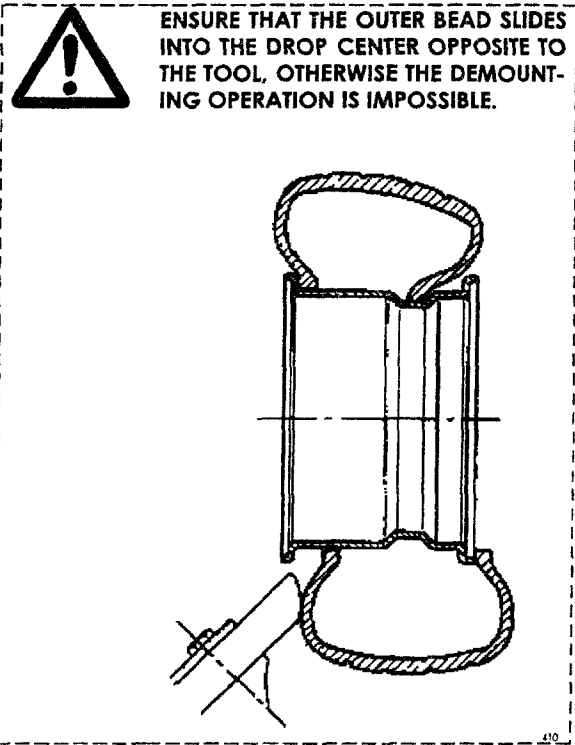

Fig.22



8. Move to the front of the tire and hold it with both hands in the last part of demounting operation to prevent the tire from falling or rolling away out of control (Fig.23).

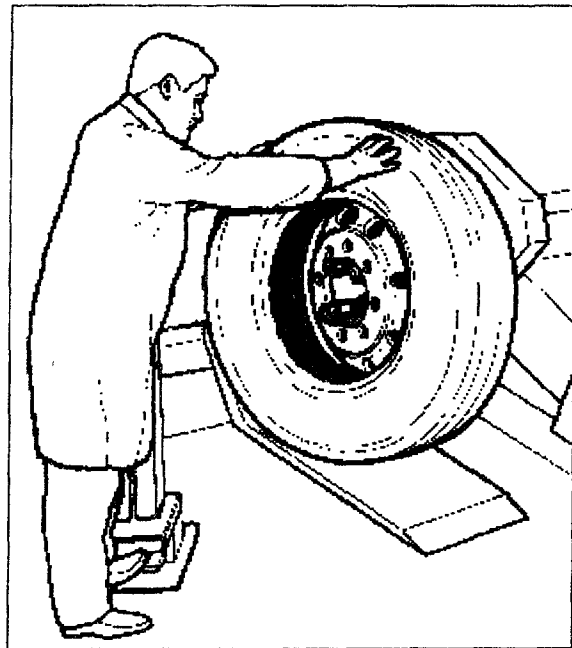

Fig.23

5.3 MOUNTING TUBELESS TRUCK TIRES
(UP TO 13" WIDE)

1. Liberally lubricate the entire inner surface of the rim and the tire beads. Attach the mounting clamp (Fig.24) to the outer rim flange with the valve at 11 o'clock and the clamp at 12 o'clock.

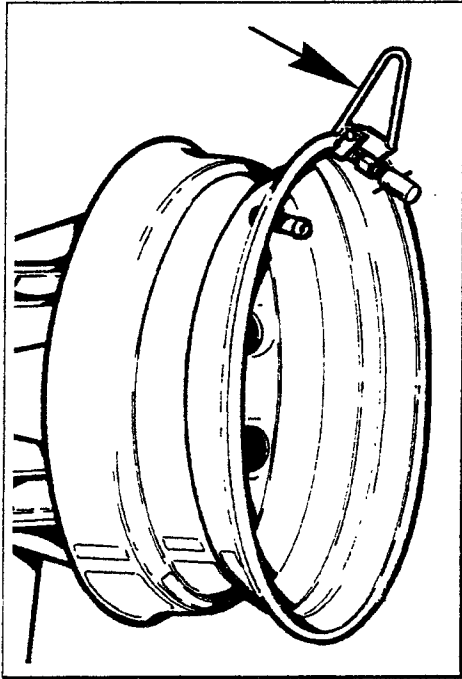

Fig.24

If the rim is made of a light-alloy, the rim shape may not allow the standard mounting clamp to be attached. In such a case use the light-alloy mounting clamp (option). The clamp can be used as shown in Fig.25 or 26.

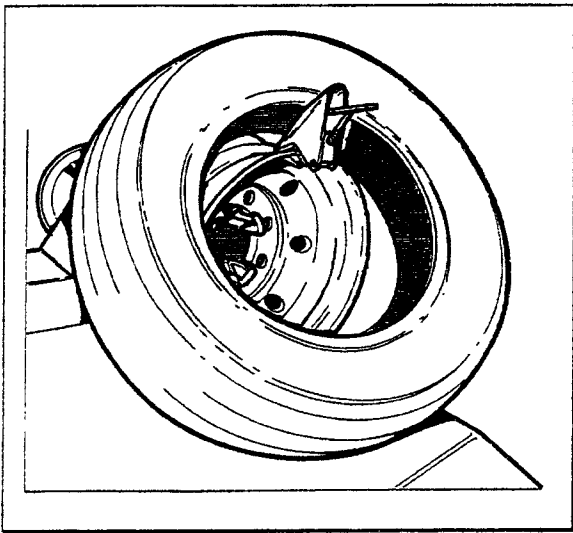

Fig.25

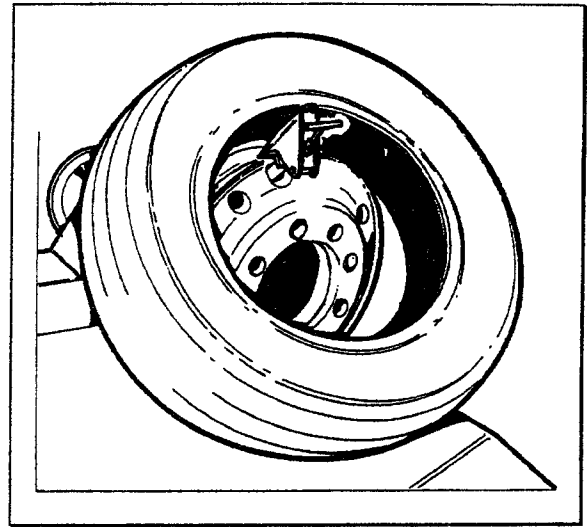

Fig.26

2. Move the chuck arm all the way down. Roll the tire on the footboard and hang it onto the mounting clamp (Fig.27).

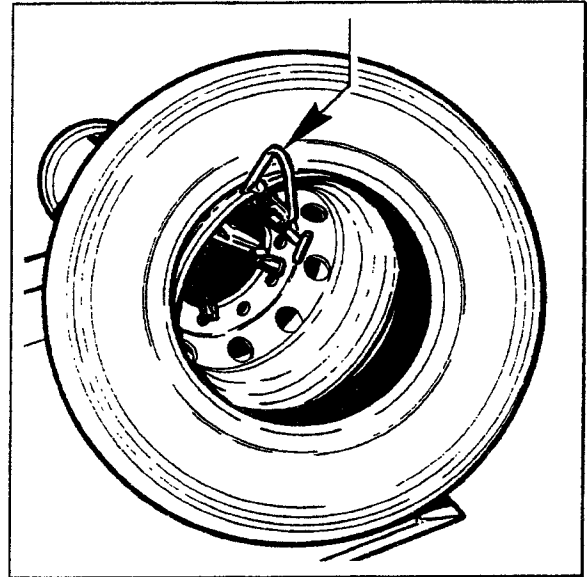

Fig.27

- Lift the chuck arm and position the mounting hook or tubeless roller approximately 1.5 cm (1/2") to the inside of the rim edge and approx. 1.5 cm (1/2") away from the rim edge (Fig.28). The mounting clamp is at 11 o'clock approximately.

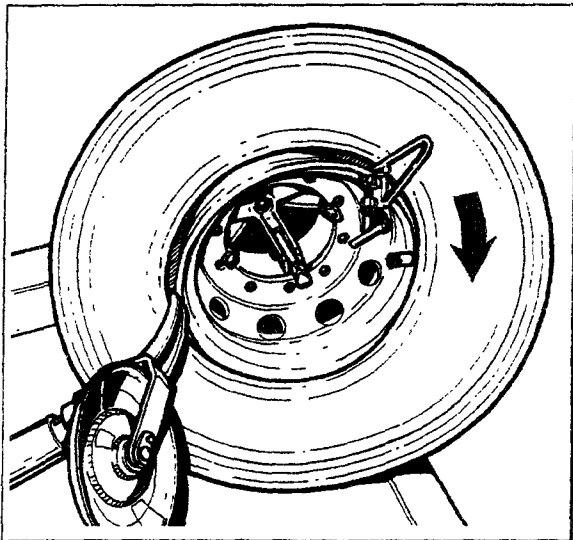

Fig.28

NEVER USE HAND PRESSURE TO HOLD THE TIRE ONTO THE RIM.

- Turn the chuck clockwise until the tire is completely mounted (Fig.29).

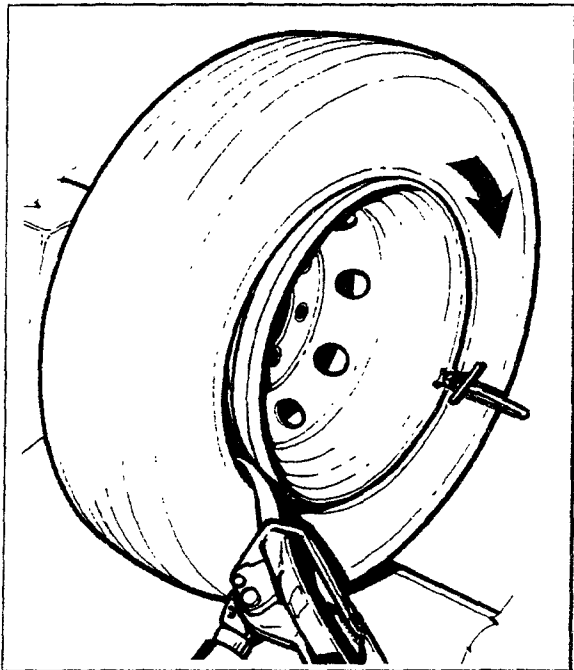
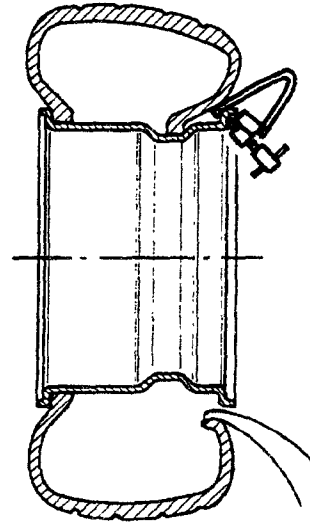

Fig.29

ENSURE THAT THE OUTER BEAD DESCENDS INTO THE DROP CENTER WHEN THE CLAMP IS OPPOSITE TO THE TOOL.



STOP THE CHUCK BEFORE ONE COMPLETE TURN IS MADE TO AVOID SERIOUS DAMAGE TO THE MOUNTING CLAMP AND TO THE RIM.

DO NOT INFLATE THE TIRE ON THE MACHINE. THIS MACHINE IS NOT AN INFLATION DEVICE. FOR INFLATION PLACE THE WHEEL IN AN APPROVED INFLATION RESTRAINT DEVICE (IN THE UNITED STATES OF AMERICA CONSULT O.S.H.A. REGULATIONS CONCERNING THE PROPER SERVICING OF TRUCK WHEELS AND RIMS).

5.4 DEMOUNTING DUPLEX AND SUPERSINGLE TUBE-LESS TRUCK TIRES (OVER 13" WIDE)

NOTE:
FOR THIS OPERATION THE MOUNT/DEMOUNT TOOL IS REQUIRED.

1. Break the bead of the tire as described in #5.2.1.- 5.2.6.
2. For this type of tire it is not possible to demount both beads at the same time as described in #5.2.7.
Engage the hook of the mount/demount tool between the bead and the rim.
3. Lift the chuck arm enough to clear the hook 2-3 cm (1"-1 1/2") from the rim flange. Move the mount/demount tool towards the outside. This will allow you to place the long bar in between the bead and the rim flange for necessary prying (Fig.30).

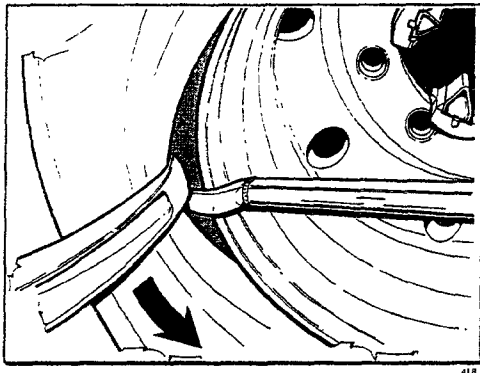

Fig.30

4. Rotate the chuck counter clockwise until the outer bead is completely demounted (Fig.31).

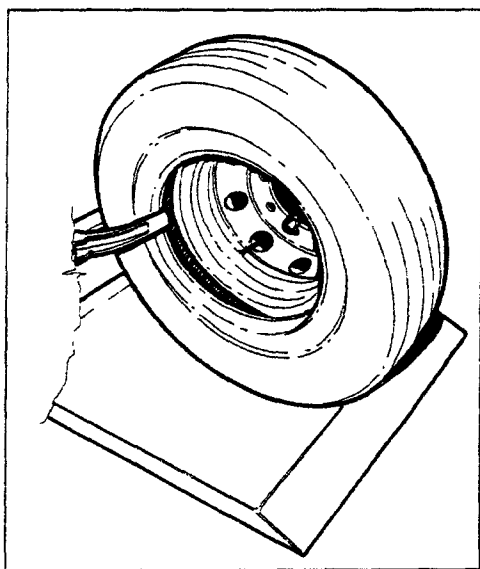

Fig.31

5. Demount the inner bead with the bead breaker disc, as described in @5.2.7. (Fig.32).

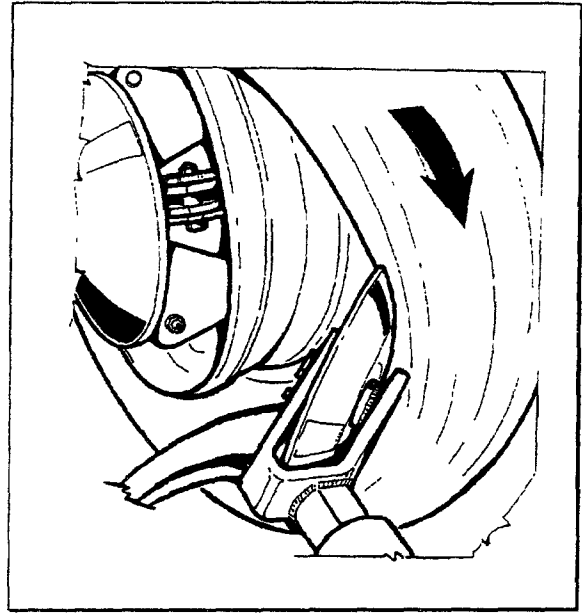

Fig.32

5.5 MOUNTING DUPLEX AND SUPERSINGLE TUBELESS TRUCK TIRES (OVER 13" WIDE)

1. Hang the inner bead of the tire on the mounting clamp (Fig.33).

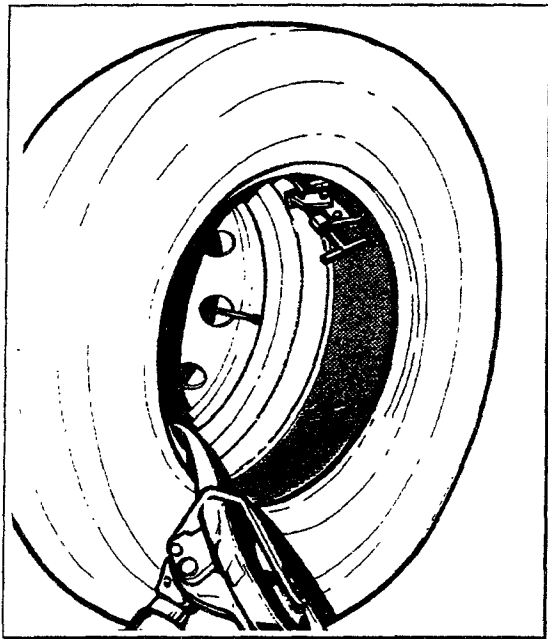

Fig.33

2. Position the mounting hook about 3/4" (1.5 cm) to the inside of the rim edge and 1/2" (1 cm) away radially. Rotate the chuck clockwise. Normally less than 1/4 of a revolution is sufficient to mount the first bead (Fig.34).

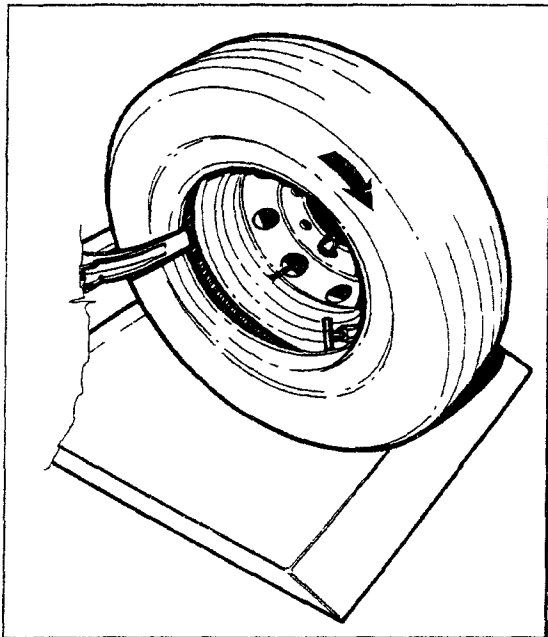

Fig.34

3. Reattach the mounting clamp to the rim flange with the valve after the mounting clamp, following the rotation direction (Fig.35).

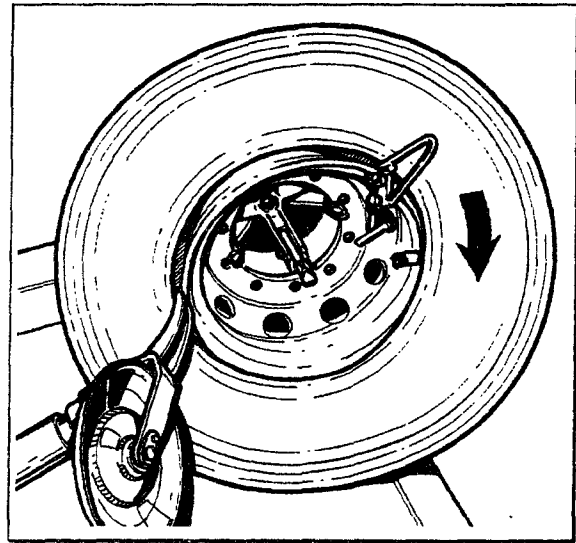

Fig.35

4. Rotate the chuck clockwise until the tire is completely mounted. Ensure that outer bead descends into the drop center when the clamp is opposite to the mount/demount tool (Fig.36).

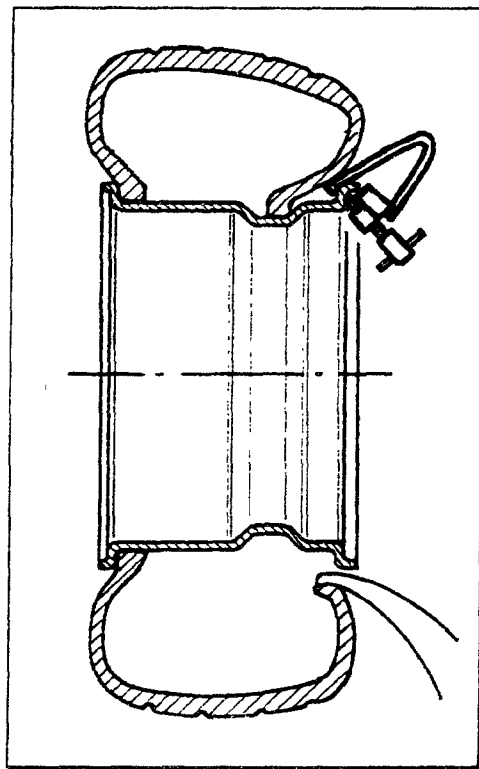



Fig.36

 **NEVER USE HAND PRESSURE TO HOLD THE TIRE INTO THE RIM.**

 **STOP THE CHUCK BEFORE ONE COMPLETE TURN IS MADE TO AVOID SERIOUS DAMAGE TO THE MOUNTING CLAMP AND TO THE RIM.**

 **DO NOT INFLATE THE TIRE ON THE MACHINE. THIS MACHINE IS NOT AN INFLATION DEVICE. FOR INFLATION PLACE THE WHEEL IN AN APPROVED INFLATION RESTRAINT DEVICE (IN THE UNITED STATES OF AMERICA CONSULT O.S.H.A. REGULATIONS CONCERNING THE PROPER SERVICING OF TRUCK, WHEELS AND RIMS).**

5.6 DEMOUNTING TIRES FROM MULTI-PIECE RIM/WHEEL ASSEMBLIES

The multi-piece rim/wheel assembly can be in two or more pieces (Fig.37).

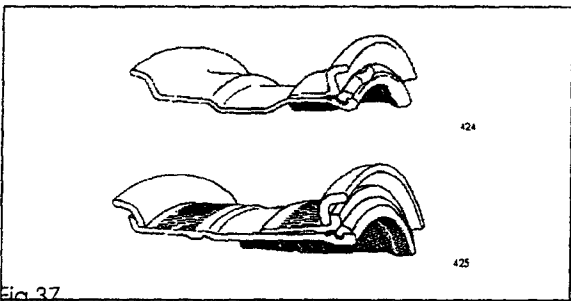

Fig.37

1. Remove all wheel-weights from the rim. Remove the valve stem or core and deflate the tire.
2. Position the tool close to the rim edge (Fig.38). When the lock ring is stuck to the bead, (on the O.T.R. tires) to make it to break the bead, it is necessary to hold it to the rim with the appropriate clamp #4007611 (on request).

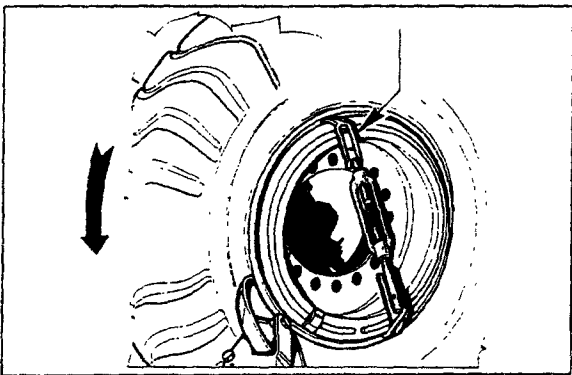

Fig.38

3. Turn the chuck counter-clockwise and the break bead as described in @5.2.1.-5.2.3. Do not lubricate.
4. To remove the lock ring, squeeze one edge with the proper bar and place the bead breaker disc as shown in Fig.39.

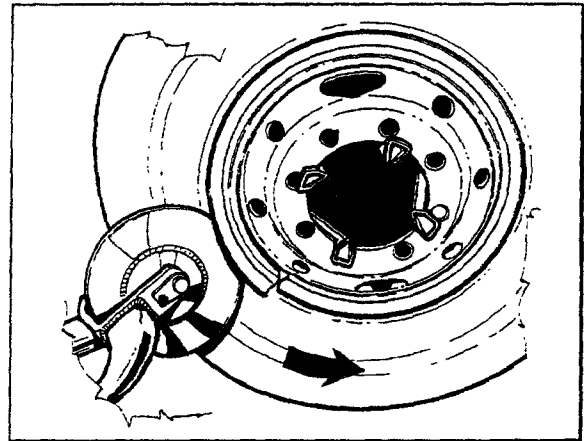



Fig.39

5. Turn the chuck clockwise (or counter-clockwise) until the lock ring is completely removed.

 **NO ONE SHOULD STAND IN FRONT OF THE WHEEL WHEN REMOVING THE LOCK RING.**

Continue to demount all components of the rim manually or with the disc tool.

6. When breaking the inner bead be sure not to damage the valve stem (Fig.40).

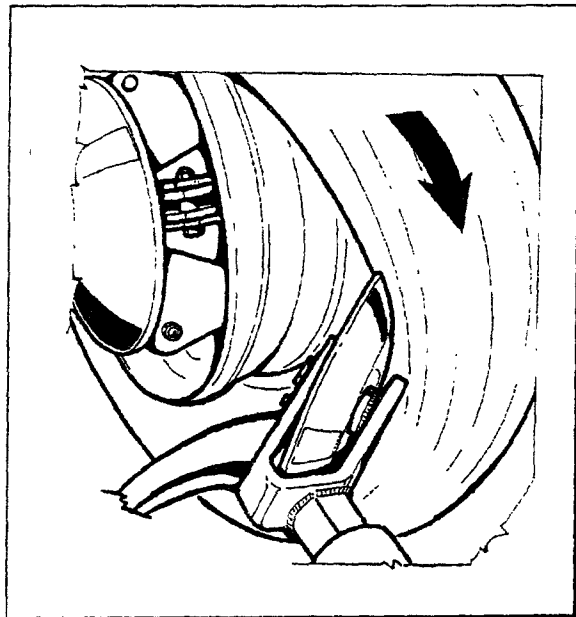

Fig.40

5.7 MOUNTING TIRES ONTO MULTI-PIECE RIM/WHEEL ASSEMBLIES

1. Roll the tire on the footboard (the tube and flap must be in place).

NOTE:

O.T.R. TIRES AND RIMS ARE VERY HEAVY AND AN OUTSIDE LIFTING TOOL MAY BE REQUIRED.

For tube type only, the valve should be placed at 12 o'clock, for easier mounting.

2. Slide the tire onto the rim with the footboard or with the bead breaker disc, if necessary.
3. Mount all the assembly components.
4. Engage one edge of the lock ring in its seat and complete the mounting process with the bead breaker disc. In the initial mounting phase hold the rim edge in its seat with a bar (Fig.41).

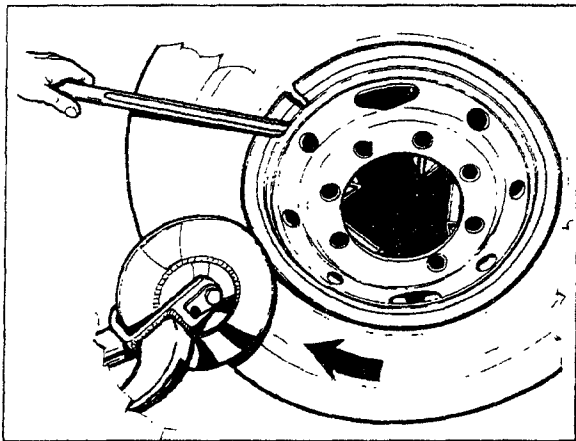

Fig.41



DO NOT INFLATE THE TIRE ON THE MACHINE. THIS MACHINE IS NOT AN INFLATION DEVICE. FOR INFLATION PLACE THE WHEEL IN AN APPROVED INFLATION RESTRAINT DEVICE (IN THE UNITED STATES OF AMERICA CONSULT O.S.H.A. REGULATIONS CONCERNING THE PROPER SERVICING OF TRUCK, WHEELS AND RIMS).

5.8 DEMOUNTING TRACTOR AND O.T.R. WHEELS WITH ONE-PIECE RIMS

These wheels may be tube-type or tubeless. The rim has a slightly conical surface and a very high rim flange (Fig.42) which does not allow you to demount the tire by simple pressure as described in @5.2.

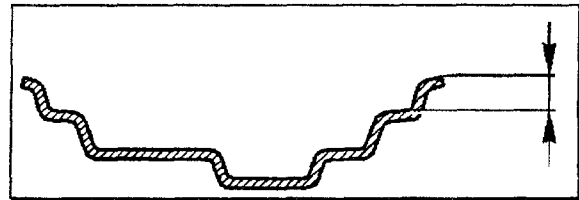

Fig.42

1. Remove all wheel-weights from the rim. Remove the valve stem or core and deflate the tire.
2. Place the disc tool next to the rim edge and bead break the inner bead as described in @5.2.
3. Break the outer bead in the same way, taking care not to damage the valve stem (Fig.43).

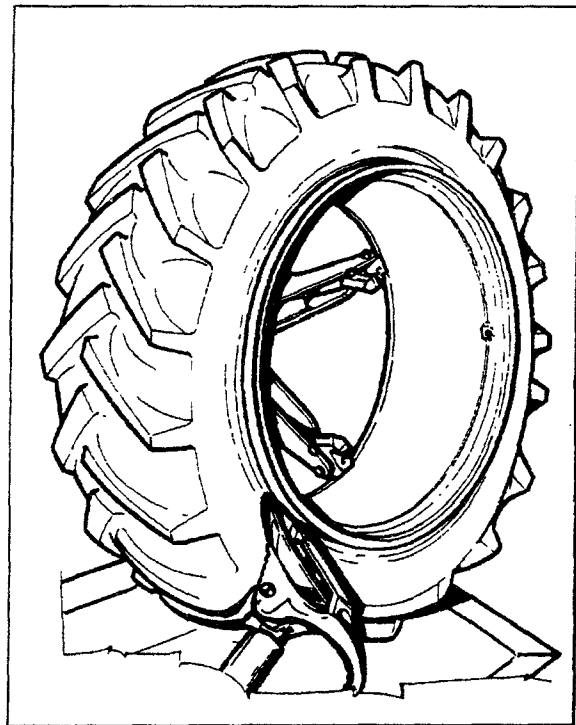

Fig.43

4. Lubricate both beads and the rim surface (Fig.44).

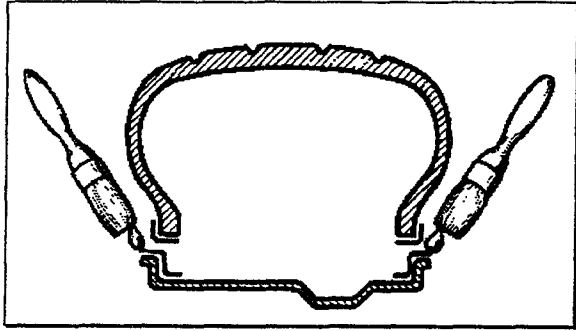

Fig.44

5. Place the hook tool between bead and rim (Fig.45).

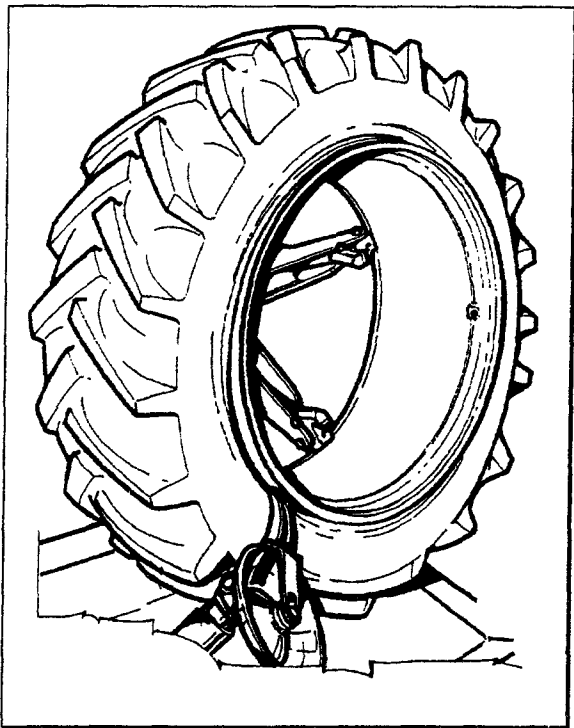

Fig.45

6. Lift the chuck arm to move the hook tool away from the rim edge (1" or 2-3 cm). Move the tool towards the outside to apply the long tire bar (Fig.46).

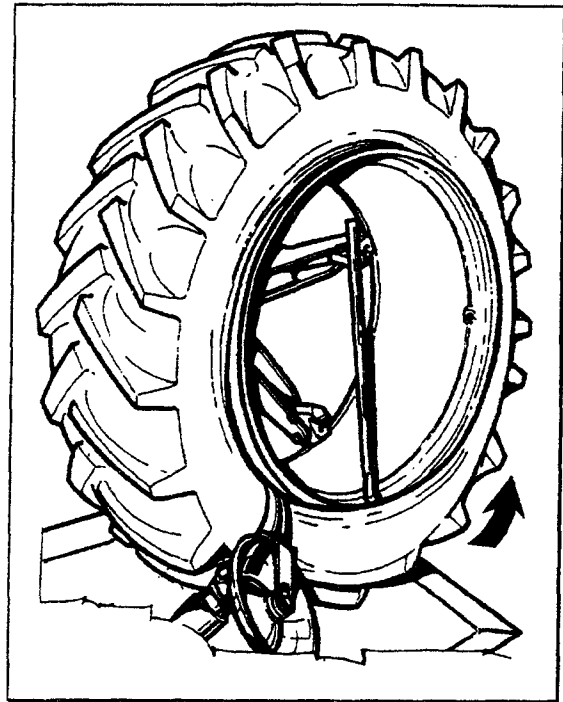

Fig.46

7. Turn the chuck counter-clockwise until the outer bead is completely demounted (Fig.47).

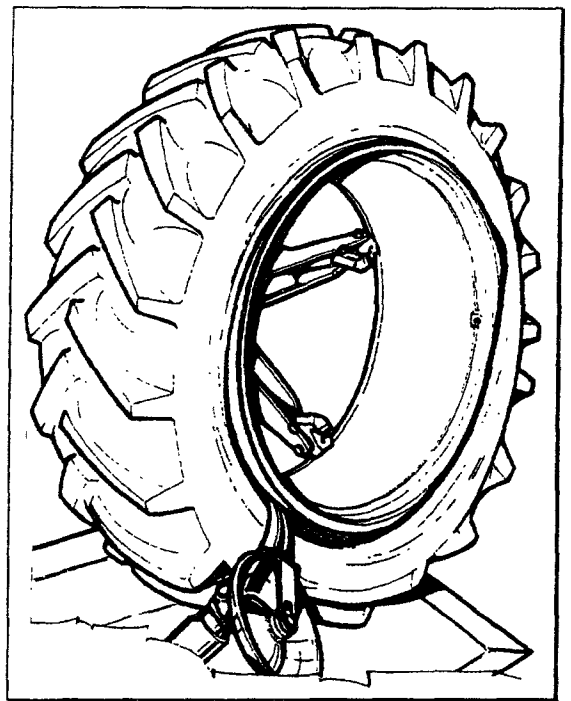

Fig.47

8. If the tire is tube-type, push the valve stem towards the inside of the rim.

9. Lift the toolholder arm to the rest position. Shift the tire from the rim, moving the toolholder carriage towards the outside: this will make it much easier to extract the tube (Fig.48).

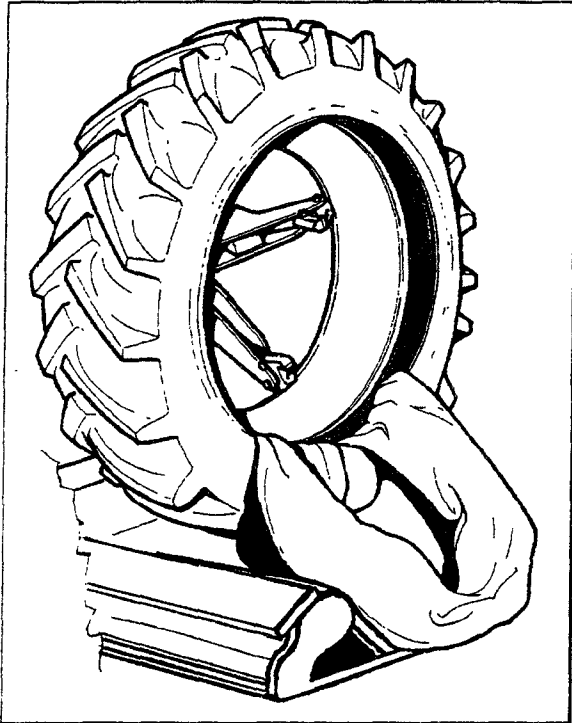

Fig.48

10. Place the hook tool as in Fig.49.

The edge of the hook should be about 2-3 cm (1") away radially from the rim edge and about 2-3 cm (1") to the outside.

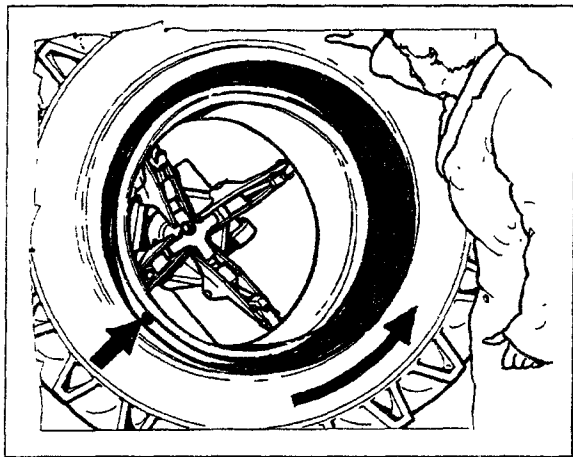

Fig.49

11. Put the long tire bar in between the bead and the rim.
12. Rotate the chuck counter-clockwise until the tire is completely demounted.



DURING THE FINAL PHASE OF THE DEMOUNTING OPERATION REMOVE THE TIRE BAR AND HOLD THE TIRE WITH BOTH HANDS, IN ORDER TO KEEP IT IN A VERTICAL POSITION.

5.9 MOUNTING TRACTOR AND O.T.R. WHEELS ON ONE-PIECE RIMS

1. Liberally lubricate both beads and the rim.
2. Firmly fit the mounting clamp to the outer rim flange at 9 o'clock. Roll the tire onto the footboard and hang it on the mounting clamp attached to the rim edge.
3. Place the hook tool as shown in Fig.50. The edge of the hook should be about 2-3 cm (1") away radially from the rim edge and 2-3 cm (1") to the outside.

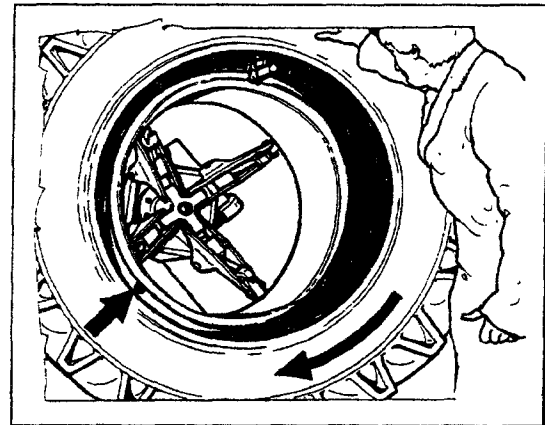

Fig.50

4. Turn the chuck clockwise until the first bead is mounted. Remove the clamp.
5. Place the tube (if any) in the tire and secure the valve stem to the rim.
6. Firmly fit the mounting clamp to the outer rim edge at 11 o'clock with valve stem at 10 o'clock in such a way as to hold the outer bead. If necessary make use of the tool to create the space to fit the clamp.

- Place the hook tool as described in 5.5.2. Rotate the chuck clockwise till the bead is completely mounted. If necessary, use the bead bar to keep the bead in the drop center (Fig.51).

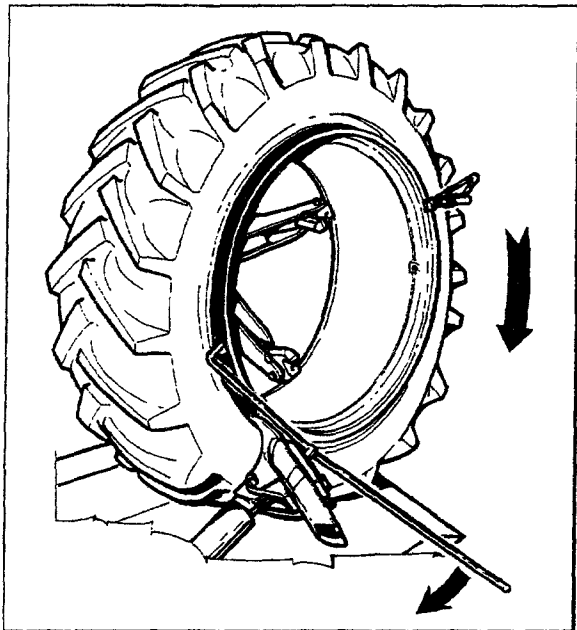

Fig.51

DO NOT INFLATE THE TIRE ON THE MACHINE. THIS MACHINE IS NOT AN INFLATION DEVICE. FOR INFLATION PLACE THE WHEEL IN AN APPROVED INFLATION RESTRAINT DEVICE (IN THE UNITED STATES OF AMERICA CONSULT O.S.H.A. REGULATIONS CONCERNING THE PROPER SERVICING OF TRUCK, WHEELS AND RIMS).

6.0 MAINTENANCE

BEFORE STARTING ANY MAINTENANCE OPERATION ENSURE THAT NO WHEEL IS MOUNTED ON THE CHUCK AND THAT THE MACHINE IS DISCONNECTED FROM THE ELECTRIC SUPPLY.

- Lubricate all points provided with a greasing nipple once a month (Fig.52).

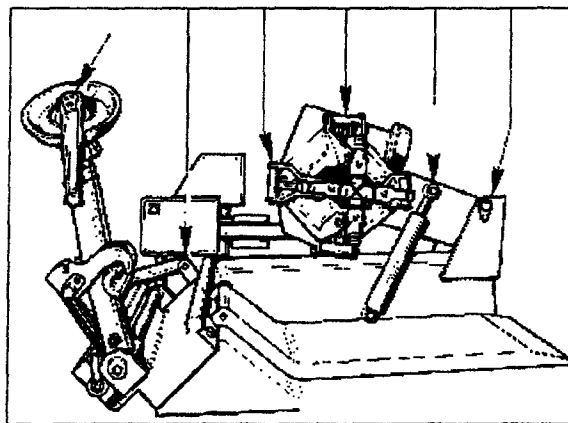

Fig.52

- Check once a month the oil level of the speed reducer (Fig. 53). The chuck arm should be completely lowered when the check is performed.

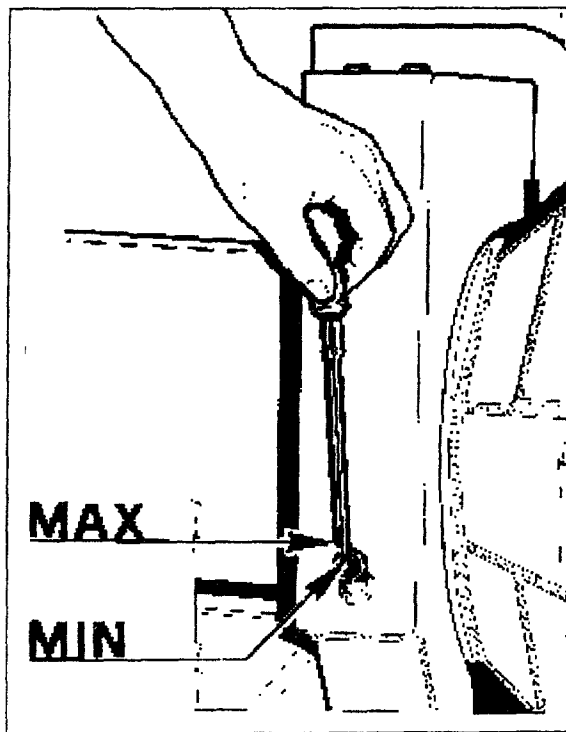

Fig.53

3. Check hydraulic oil level once a month (Fig.54).

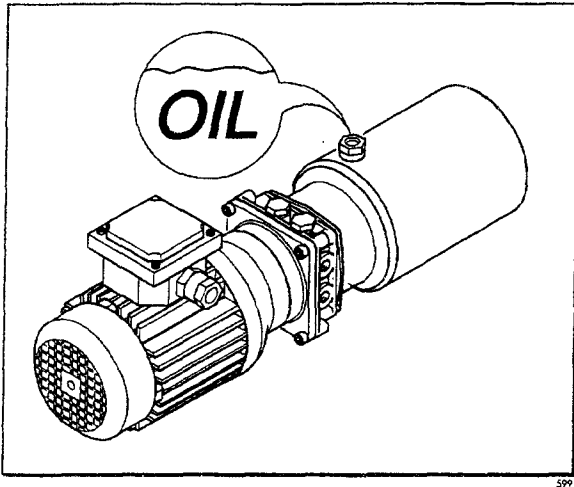

Fig.54

NOTE:
BEFORE CHECKING, ALL CYLINDERS MUST BE COMPLETELY RETRACTED.

If necessary add:

ESSO	:	Nuto H 46
SHELL	:	Tellus oil 46
TOTAL	:	Azolla 46

Oil change is not required.

4. Clean and grease once a month the sliding bar of the toolholder arm (Fig.55).

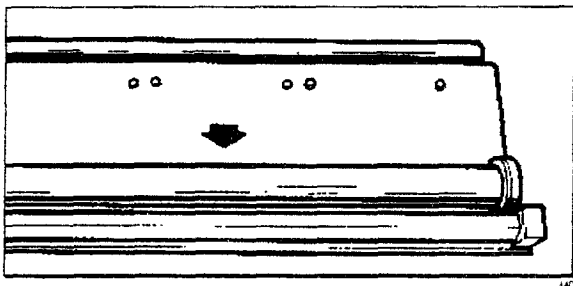

Fig.55

5. Clean the jaws of the chuck with a wire brush once a month.

7.0 MOVING THE MACHINE

In case the machine is to be moved from a working place to another, proceed as follows:

Disconnect the machine from the electric supply. Before lifting the machine, ensure that the chuck is completely closed, the chuck arm lowered, and that the arm beam support and carriage beam support are in the position indicated in Fig. 56.

Use belts of a length of mm 3000 (10') and capacity of kg 1000 (2200 lbs).

Hold the machine as depicted in Fig.56.

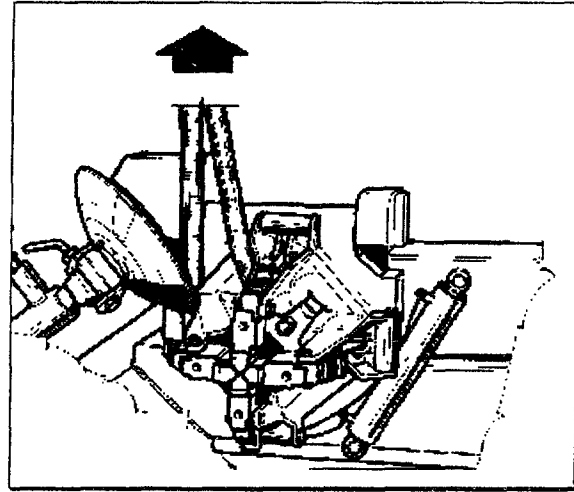

Fig.56

8.0 PUTTING THE MACHINE OUT OF SERVICE

If the machine is to be idle for a long period of time (6 months or more) it is necessary to close the chuck arm, retract all hydraulic cylinders and disconnect all power sources. Protect all parts that may be damaged, protect the hydraulic hoses that may be damaged because of a drying process.

When putting the machine back in operation, first check the condition of all previously protected parts, and check for correct functioning of all devices before using the machine again.

9.0 SCRAPPING THE MACHINE

Once it is decided to discontinue use of the machine, it must be rendered inoperable by cutting the electric cord.

Considered the machine as special waste, dismantle the machine into homogeneous parts (metal, plastic, oils etc) and dispose of according to local regulations.

10.0 TROUBLE SHOOTING

TROUBLE	CAUSE	REMEDY
Pump motor turns but none of the hydraulic movements works.	<ul style="list-style-type: none"> • The automatic circuit breaker is off. • A fuse of the low-voltage section is blown. • Transformer is burnt out. 	<ul style="list-style-type: none"> • Disconnect the machine from electric supply. Open the electric cabinet and check the automatic circuit breaker and low voltage fuses. Reset the circuit breaker or replace the fuses as needed. • THIS OPERATION CAN BE PERFORMED ONLY BY QUALIFIED PERSONNEL. • Call the authorized service center for assistance.
Pump motor does not turn but the chuck motor operates normally.	<ul style="list-style-type: none"> • The thermal safety switch protecting the hydraulic motor is/was activated. 	<ul style="list-style-type: none"> • Disconnect the machine from electric supply. Open the electric cabinet and reset the thermal safety switch. • THIS OPERATION CAN BE PERFORMED ONLY BY QUALIFIED PERSONNEL.
The thermal switch that protects the pump motor is very easily activated.	<ul style="list-style-type: none"> • The voltage of the electric line is too low. 	<ul style="list-style-type: none"> • Check voltage on electric supply. • THIS OPERATION CAN BE PERFORMED ONLY BY QUALIFIED PERSONNEL.
The circuit breaker is very easily activated.	<ul style="list-style-type: none"> • The machine is not stable on the floor. • The electric cabinet is not firmly attached. • The voltage of the electric line is too low. 	<ul style="list-style-type: none"> • Check that the machine is securely bolted to the floor. • Attach the electric cabinet firmly. • Check voltage on electric supply. • THIS OPERATION CAN BE PERFORMED ONLY BY QUALIFIED PERSONNEL.
The transformer protection fuses easily blow.	<ul style="list-style-type: none"> • Short circuit in the electric cord connecting the portable control unit to the electric cabinet. 	<ul style="list-style-type: none"> • Call the authorized service center for assistance.
The chuck does not hold the wheel firmly.	<ul style="list-style-type: none"> • The teeth of the chuck jaws are full of dirt or worn out. • The protectors for light-alloy wheels are damaged or worn out. • The check valve or manifold of the chuck cylinder leak oil.. 	<ul style="list-style-type: none"> • Clean the teeth of the chuck jaws with a wire brush. • Replace the protectors for alloy wheels. • Call the authorized service center for assistance..

ACCU model 4520

Catalogo ricambi

Spare parts

Pieces detachées

Ersatzteile

Repuestos

* All'ordine specificare: tipo macchina e matricola codice e quantità del particolare.

* On order specify: type of machine and serial number item code and quantity.

* A la commande: bien préciser le type de la machine, le n de serie, la référence de pièce, la quantité.

* Bei Auftragserteilung anzugeben: Maschinentype, Seriennummer, Artikel-Code, Menge.

En cada pedido hay que especificar : el tipo de máquina y su número de matrícula, el número de código de la pieza requerida y su cantidad.

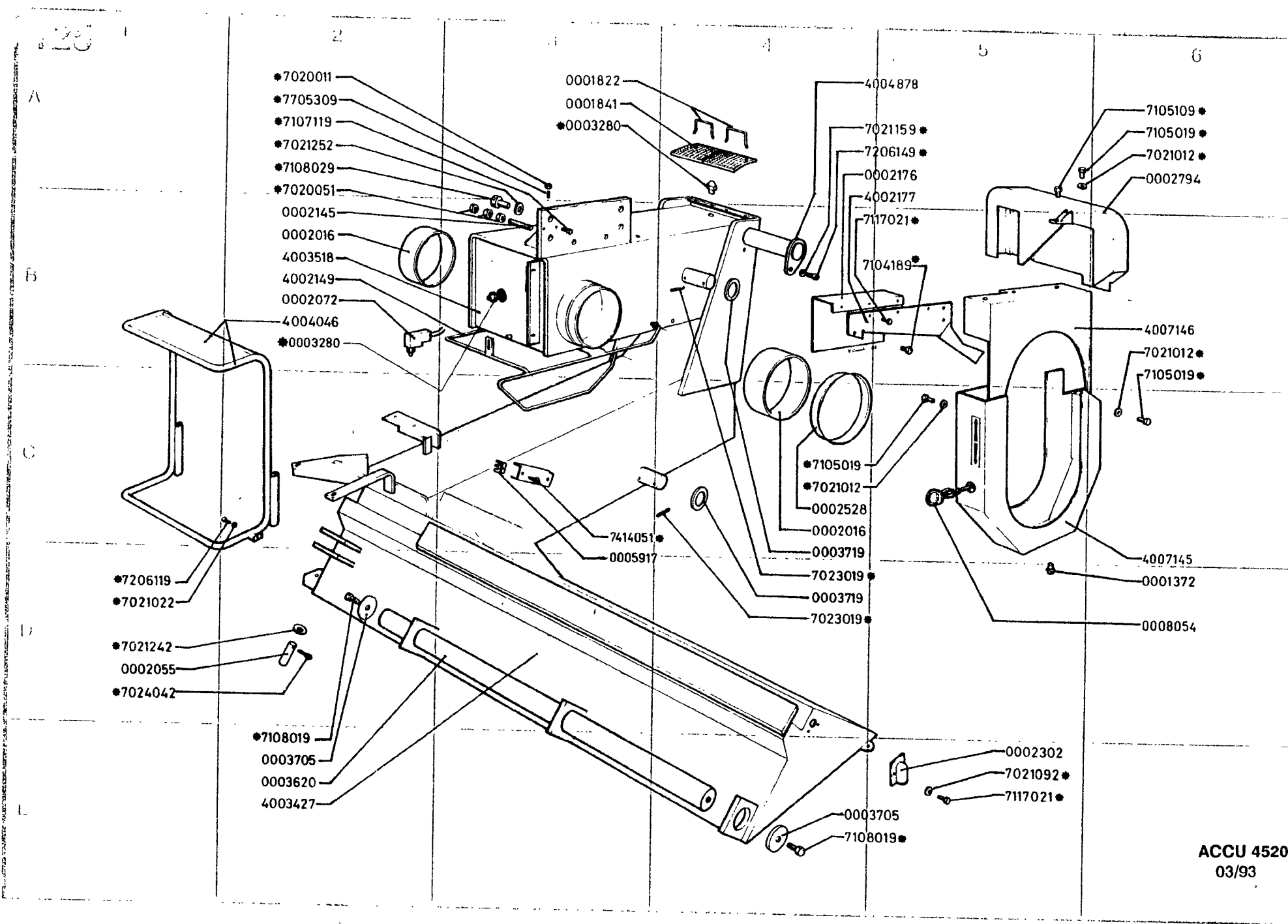

- 7020011
- 7705309
- 7107119
- 7021252
- 7108029
- 7020051

- 0001822
- 0001841
- 0003280

- 4004878
- 7021159 •
- 7206149 •
- 0002176
- 4002177
- 7117021 •
- 7104189 •

- 7105109 •
- 7105019 •
- 7021012 •
- 0002794

- 0002145
- 0002016
- 4003518
- 4002149
- 0002072
- 4004046
- 0003280

- 7105019 •
- 7021012 •
- 0002528
- 0002016
- 0003719
- 7023019 •
- 0003719
- 7023019 •

- 4007146
- 7021012 •
- 7105019 •

- 7206119
- 7021022

- 7021242
- 0002055
- 7024042

- 7108019
- 0003705
- 0003620
- 4003427

- 7414051 •
- 0005917

- 7105019
- 7021012
- 0002528
- 0002016
- 0003719
- 7023019 •
- 0003719
- 7023019 •

- 4007145
- 0001372
- 0008054

- 0002302
- 7021092 •
- 7117021 •

- 0003705
- 7108019 •

ACCU 4520
03/93

438

1

2

3

4

5

A

B

C

D

E

0017931 - HP 3/4
0017929 - HP 2/3

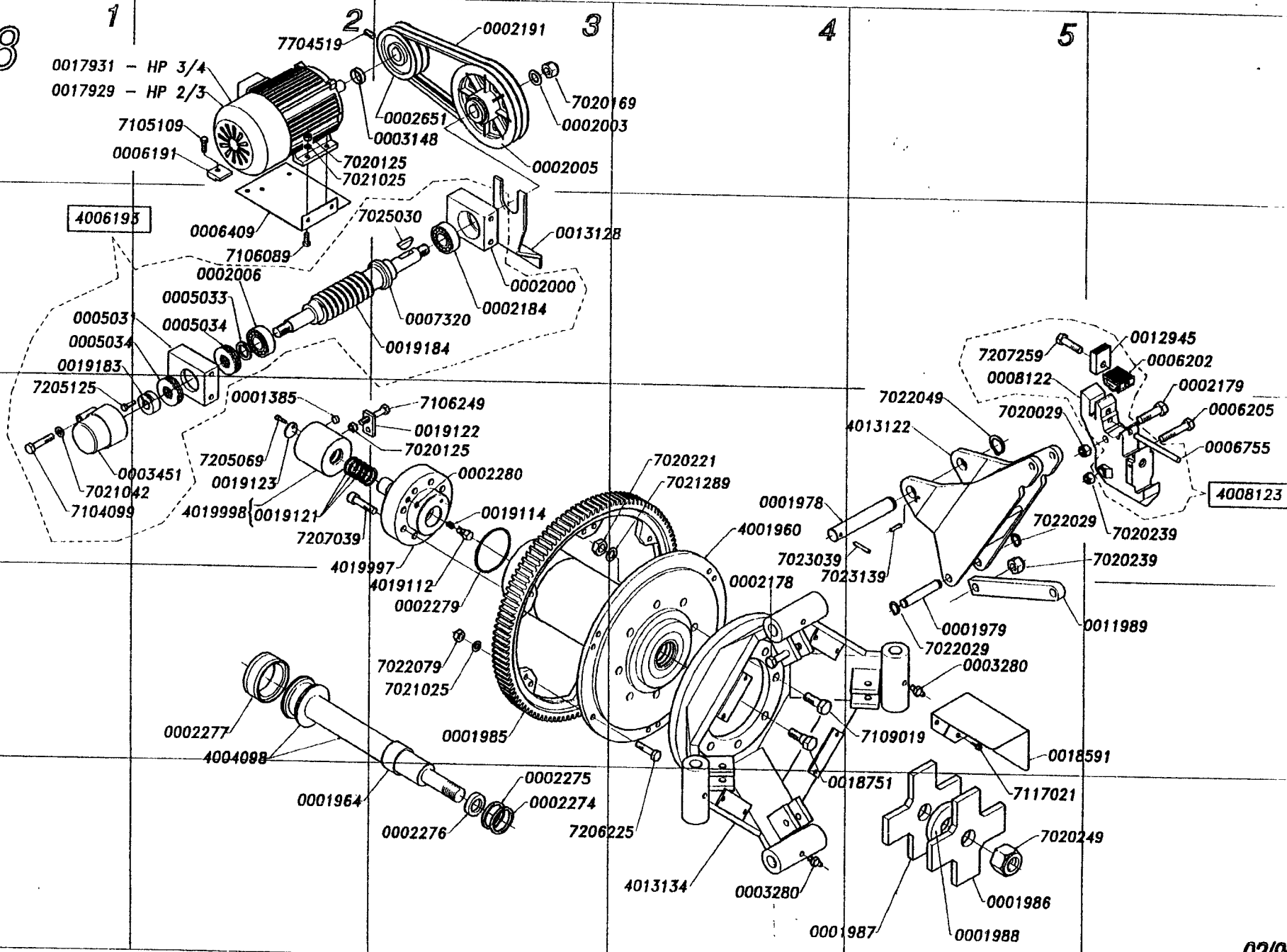

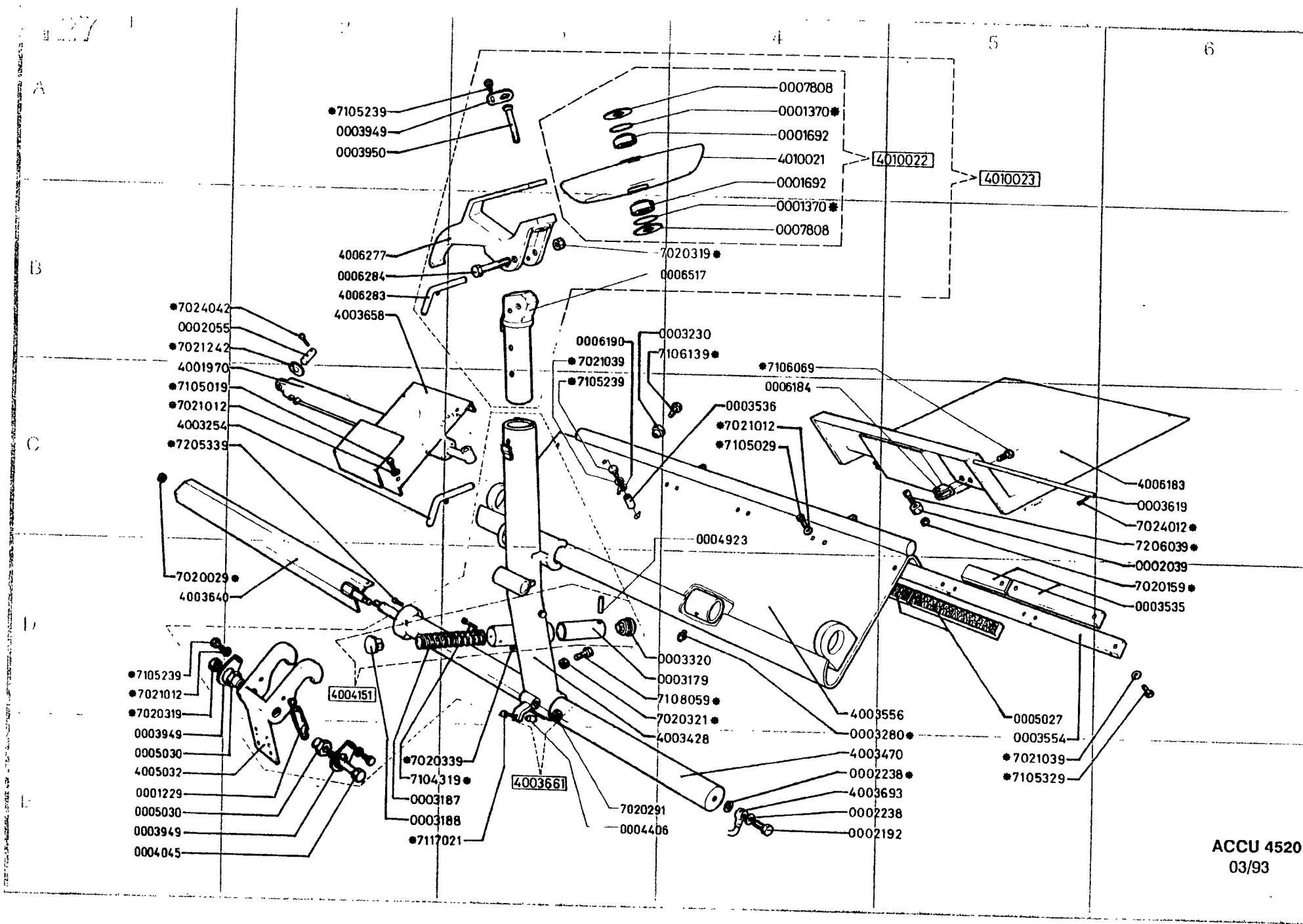

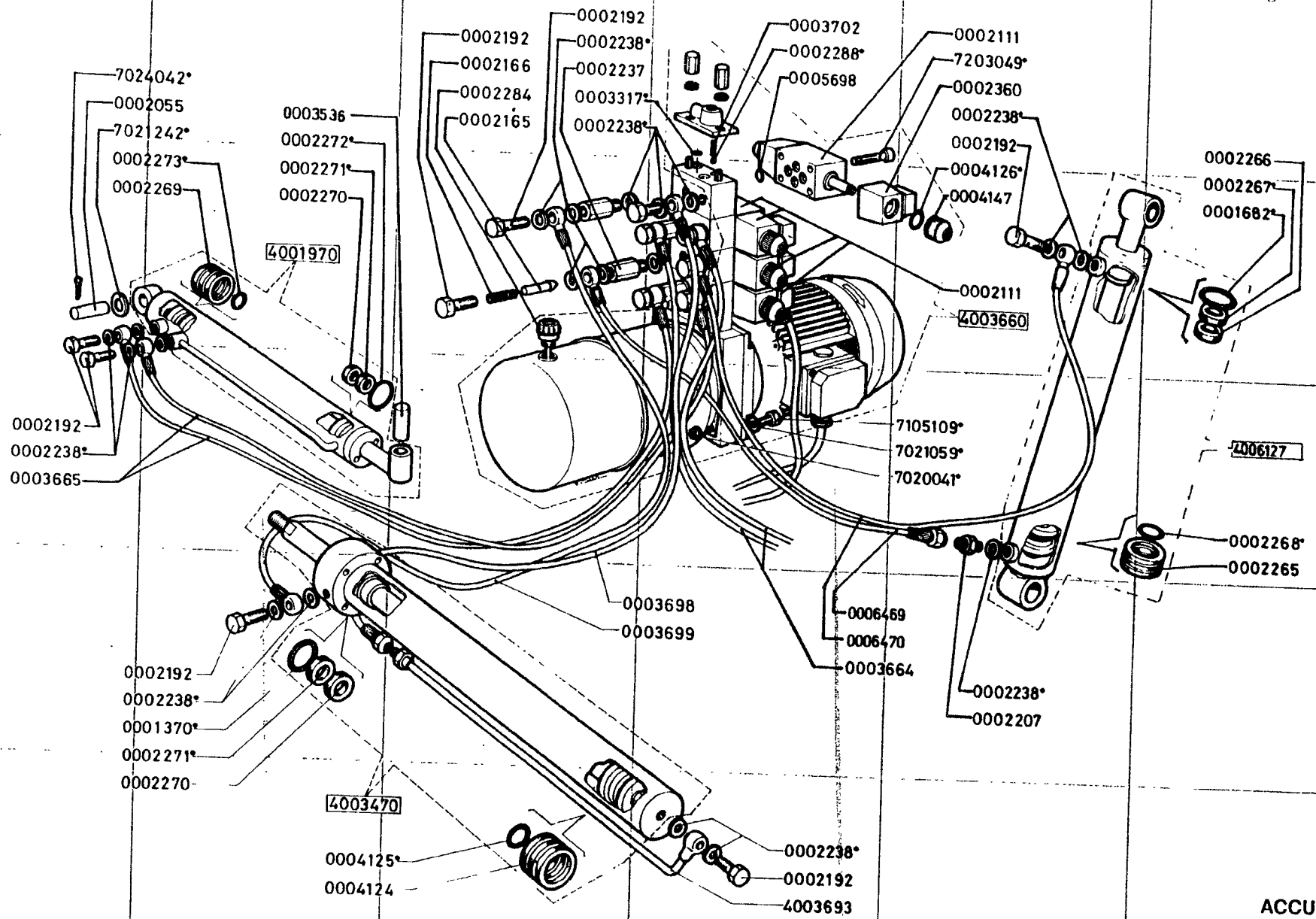

ACCU 4520
 03/93

A
B
C
D
E

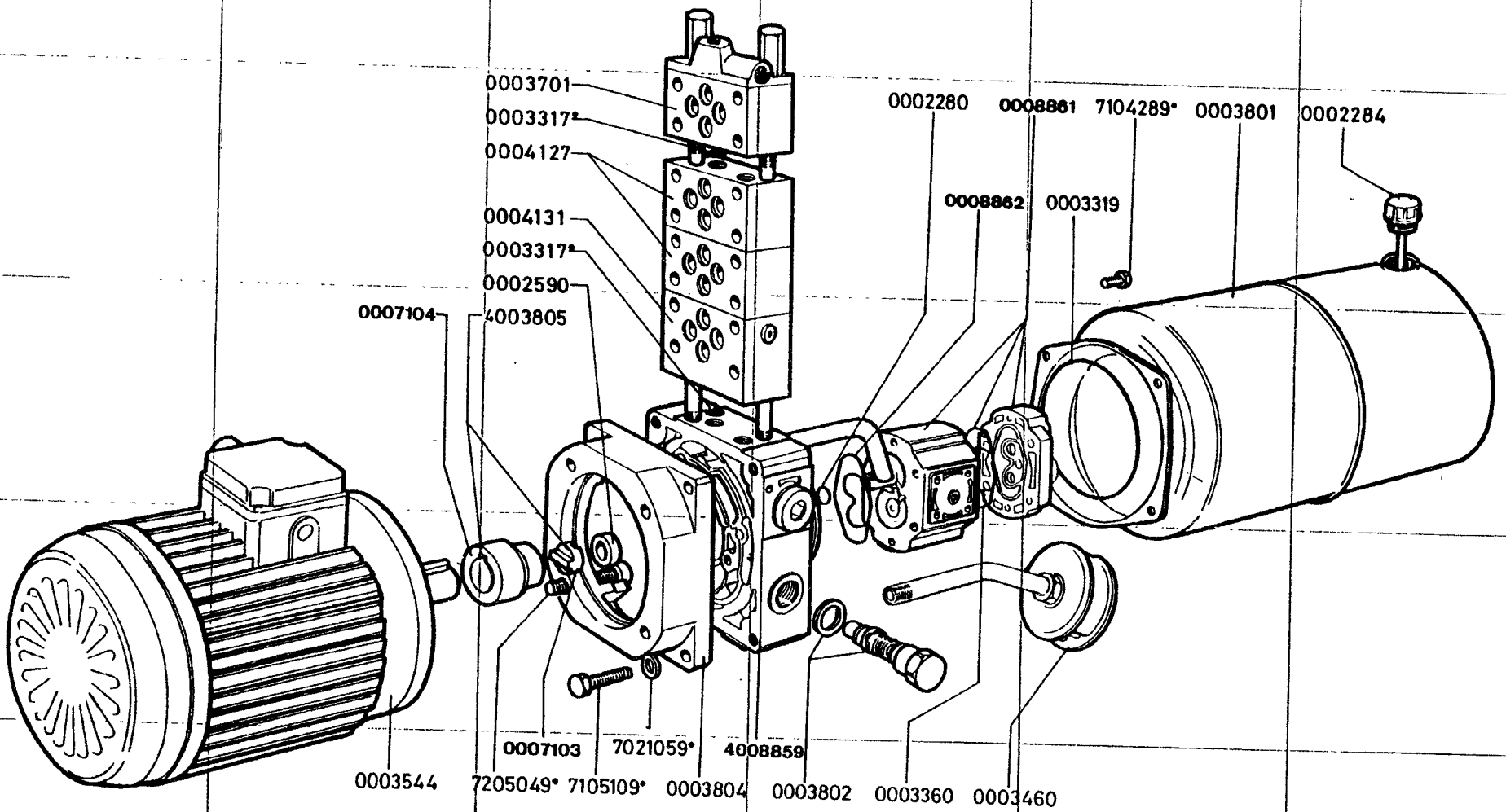

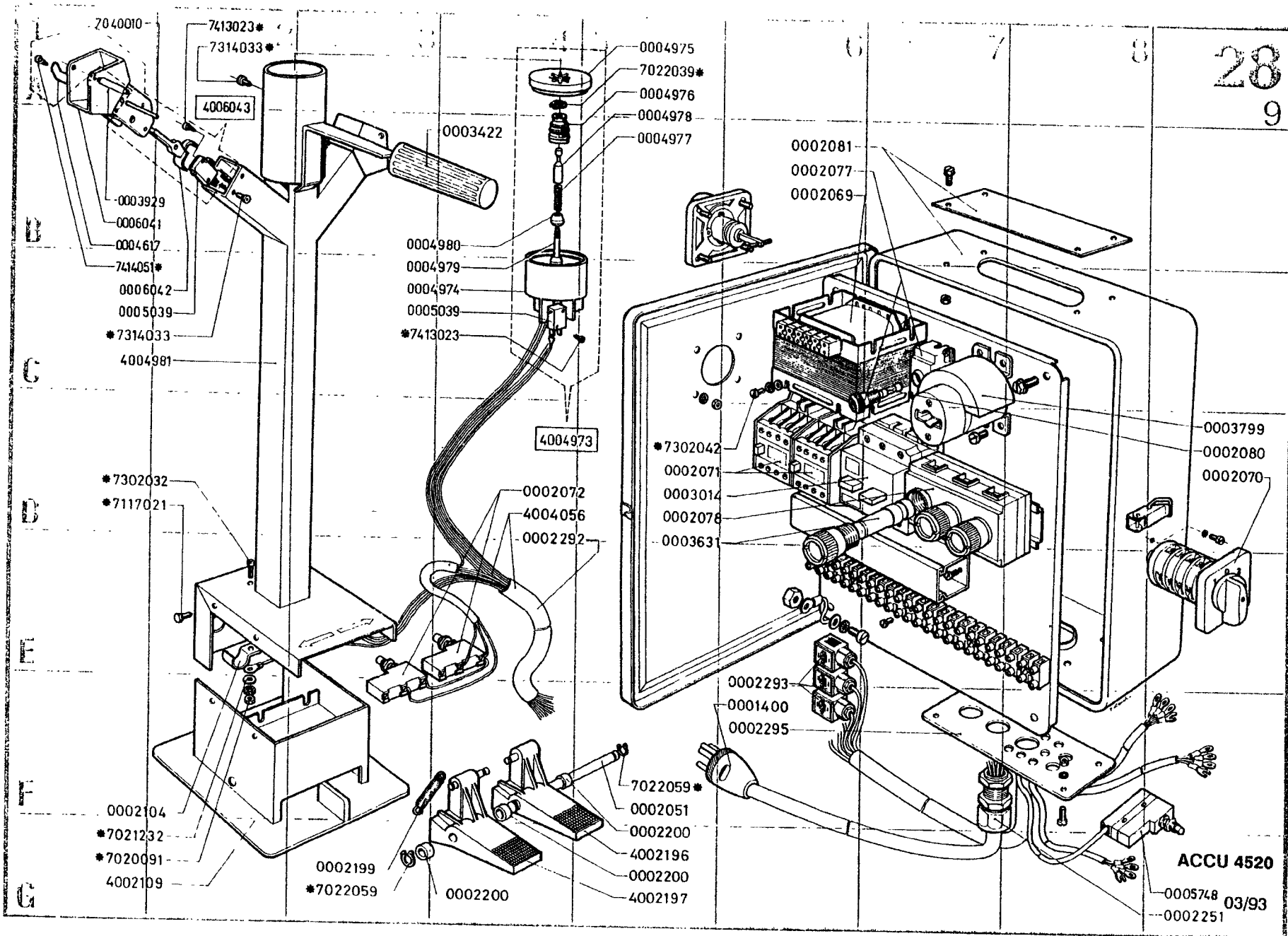

COMMERCIAL SPARE PARTS



7117021 = 10E x 13 DIN 7976/B2



7413023 = 4P x 16 DIN 7981
7314033 = 6P x 9.5 DIN 7981
7414051 = 6P x 6.5 DIN 7981



7020011 = M8 6S
7020041 = M6 6S
7020051 = M12 6S
7020091 = M4 6S
7020121 = M10 6S
7020221 = M16 6S
7020321 = M14 6S



7020029 = M14 5S I
7020159 = M10 5S I
7020189 = MB 16 x 1,5 5S I
7020239 = M12 5S I
7020249 = MB 27 x 2 5S I
7020319 = M20 5S I
7020339 = M6 5S I



7021012 = D8
7021022 = D10
7021042 = D6
7021092 = D5
7021232 = D4
7021242 = D20
7021252 = D14



7104099 = 6 x 35 8G
7104189 = 6 x 12 8G
7104319 = 8 x 55 8G
7105029 = 8 x 25 8G
7105019 = 8 x 16 8G
7105109 = 8 x 20 8G
7105239 = 8 x 12 8G
7105329 = 8 x 40 8G
7106049 = 10 x 40 8G
7106069 = 10x20 8G
7106089 = 10x35 8G
7106139 = 10x50 8G
7107119 = 12 x 16 8G
7108019 = 14 x 20 8G
7108029 = 14 x 35 8G
7108059 = 14 x 25 8G
7109019 = 16 x 60 8G



7204039 = 6x16 8G
7205339 = 8 x 45 8G
7206039 = 10 x 60 8G
7206079 = 10 x 35 8G
7206119 = 10 x 20 8G
7206149 = 10 x 25 8G
7207039 = 12x50 8G
7207259 = 12x45 8G



7705309 = 8 x 30 8G



7302032 = 4 x 16 6S
7302042 = 4 x 10 6S



0002288 = D 6,35 - 1/4



0001370 = D76,36x71,2x2,62 OR 149 GACO
0001566 = D12,8x9,25x1,78 OR 2037 GACO
0001682 = D75,32x68,26x3,53 OR 171 GACO
0002205 = D8,84x5,28x1,78 OR 2021 GACO
0002268 = D29,05x23,81x2,62 OR 132 GACO
0002272 = D56,27x49,21x3,53 OR 153 GACO
0002273 = D21,12x15,88x2,62 OR 121 GACO
0002279 = D92,38x85,32x3,53 OR 4337 GACO
0002280 = D11,22x7,66x1,78 OR 2031 GACO
0002281 = D46,75x39,69x3,53 OR 144 GACO
0003317 = D14,43x9,19x2,62 OR 3037 GACO
0004126 = D25,7x18,64x3,53 OR 4075 GACO



0002006 = 25x52x15 SKF 6205-2Z
0002184 = 25x52x15 SKF 6205-2RS



0005034 = SKF 51305



0002267 = D35 WRM 137169
0002270 = D25 B 12909851
0002271 = D25



7025030 = 8 x 11



7021039 = D8 DIN 6798/A
7021159 = D10 DIN 6798/A
7021289 = D16 DIN 6798/A



7021059 = D8
7021219 = D10



0002238 = 1/4



7023019 = 6 x 50 DIN 1481
7023039 = 6 x 40 DIN 1481
7023099 = 4 x 40 DIN 1481
7023139 = 6 x 20 DIN 1481



7022029 = D16
7022049 = D25
7022059 = D12



0003280 = M8



7024042 = 4 x 40
7024012 = 3 x 25