



# **ACCU 4502**

**ELECTRIC-AIR TIRE CHANGER FOR CAR,  
LIGHT TRUCK AND MOTORCYCLE WHEELS**

OPERATOR'S MANUAL  
SPARE PARTS EXPLODED DRAWINGS

**TABLE OF CONTENTS**

1.0	INTRODUCTION	Page 4
1.1	NOMENCLATURE	Page 4
1.2	SPECIFICATIONS	Page 4
1.3	DIMENSIONS OF THE MACHINE	Page 4
1.4	STANDARD ACCESSORIES	Page 5
1.5	OPTIONAL ACCESSORIES	Page 5
1.6	GENERAL PRECAUTIONS	Page 5
2.0	INSTALLATION	Page 6
2.1	ELECTRIC INSTALLATION	Page 7
2.2	AIR INSTALLATION	Page 7
3.0	CONTROLS	Page 8
4.0	MOUNTING AND DEMOUNTING-PRECAUTIONS	Page 9
4.1	DEMOUNTING TUBELESS TIRES	Page 9
4.2	MOUNTING TUBELESS TIRES	Page 11
4.3	INFLATING TUBELESS TIRES	Page 12
5.0	DEMOUNTING TUBE TYPE TIRES	Page 13
5.1	MOUNTING TUBE TYPE TIRES	Page 13
5.2	INFLATING TUBE TYPE TIRES	Page 14
6.0	MOUNTING/DEMOUNTING MOTORCYCLE TIRES	Page 14
7.0	MAINTENANCE	Page 14

**1.0 INTRODUCTION**

Congratulations on purchasing the ACCU Model 4502 electric/air tire changer.

This tire changer is designed for ease of operation, safe handling of rims, reliability and speed.

This combination of features means more profit and added versatility for your shop, enabling you to work with aluminum or magnesium alloy wheels without damaging customer's rims.

With a minimum of maintenance and care your ACCU Model 4502 will provide many years of trouble-free operation.

Please read this manual thoroughly before operating the unit. Instructions on use, maintenance and operational requirements of the machine are covered in this manual.

**1.1 NOMENCLATURE**

Before installing and using the ACCU Model 4502 it is suggested that you become familiar with the nomenclature of the machine's components.

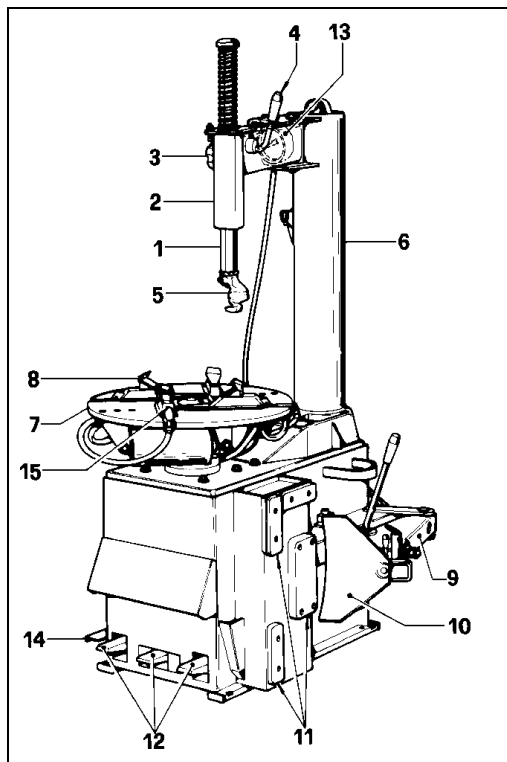

Fig.1

- 1 Vertical slide
- 2 Swing arm
- 3 Adjustment knob
- 4 Lock lever
- 5 Mount/demount tool
- 6 Tower or column
- 7 Turntable
- 8 Jaw
- 9 Bead breaker arm
- 10 Bead breaker blade
- 11 Bead breaker pads
- 12 Foot pedal controls
- 13 Inflation gauge
- 14 Bead seater/inflator pedal
- 15 Air jets

**1.2 SPECIFICATIONS**

Electric-air tire changer for car, light commercial vehicle and motorcycle tires designed for one-piece rims.

Weight	lbs 523 (238 kg)
Air pressure required	psi 110-170 (8-12 bar)
Bead breaker force	lbs 3400 (kN 15)
Motor 110 VAC 60Hz	Hp 1 (kW 0.75)
Max. torque	ftxlb 740 (Nm 1000)
Max. wheel diameter	50" (mm 1270)
Max. wheel width	14"
Rim diam. outside locking	10"-20"
Rim diam. inside locking	12"-22"
Motorcycle wheels with adapters	15"-23"

**1.3 DIMENSIONS OF THE MACHINE**

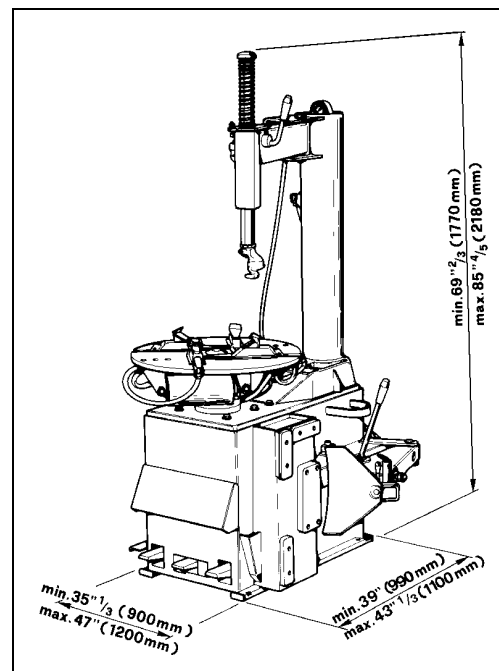
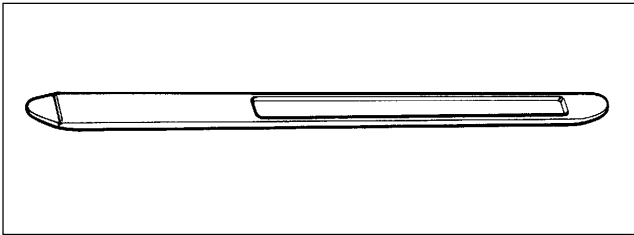

Fig.2

**1.4 STANDARD ACCESSORIES**

**#0001418 bead lifing tool (Fig.3)**



294

Fig.3

*NOTE:  
THE INFLATION GAUGE IS MOUNTED ON THE COLUMN.*

**1.5 OPTIONAL ACCESSORIES**

**#4015099 motorcycle adapter (Fig.4)**

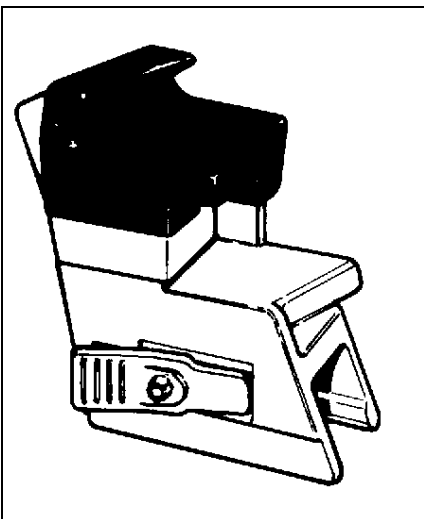

320

Fig.4

**#4008254 8" adapter (Fig.5)**

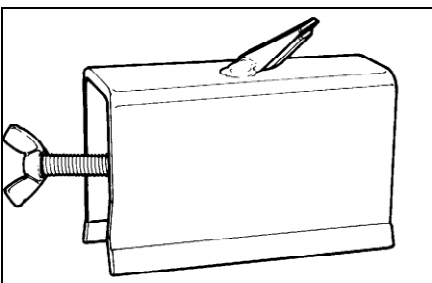

316

Fig.5

**#4025419 air filter-lubricator with water separator (Fig.6)**

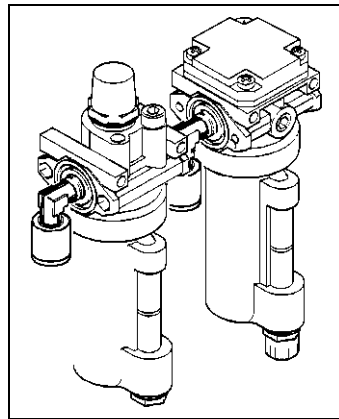

964

Fig.6

**#4003444 bead depressor tool (Fig.7)**

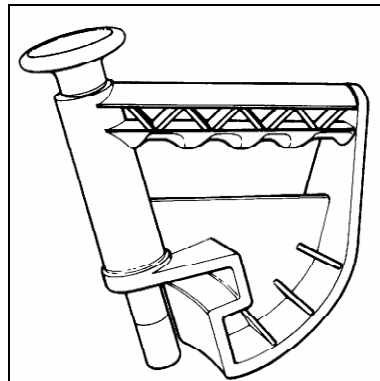

315

Fig.7

**1.6 GENERAL CAUTIONS**

**A. DURING THE USE AND MAINTENANCE OF THE MACHINE IT IS MANDATORY TO COMPLY WITH ALL LAWS AND REGULATIONS FOR ACCIDENT PREVENTION.**

**B. THE ELECTRICAL POWER SOURCE MUST HAVE A GROUND CABLE AND THE GROUND CABLE OF THE MACHINE (YELLOW WITH GREEN) MUST BE CONNECTED TO THE GROUND CABLE OF THE POWER SOURCE.**

**C. BEFORE ANY MAINTENANCE OR REPAIRS ARE ACCOMPLISHED THE MACHINE MUST BE DISCONNECTED FROM THE AIR AND ELECTRICAL SUPPLY.**

**D. NEVER WEAR TIES, CHAINS OR OTHER LOOSE ARTICLES WHEN USING, MAINTAINING OR REPAIRING THE MACHINE. LONG HAIR IS ALSO DANGEROUS AND SHOULD BE KEPT UNDER A HAT. THE USER MUST WEAR PROPER SAFETY ATTIRE IE; GLOVES, SAFETY SHOES AND GLASSES.**

## 2.0 INSTALLATION

Install the machine in a covered and dry place. Operation temperature is +41/+122 F (+5/50 C). The ACCU Model 4502 can work below 32 F, but some minor modifications are required: contact your ACCU distributor for detailed information.

**A** Place all disassembled parts on the floor.

**B** Attach the column #1 (Fig.8) to the cabinet #2 with the screws #4 and washers #3. The screws must be firmly tightened.

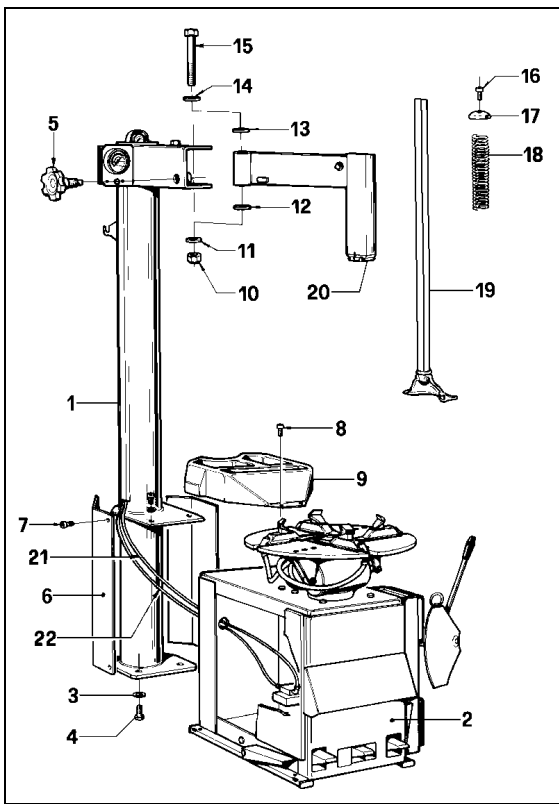

Fig.8

**C** Attach the air hose #21 and the air hose #22.

**D** Attach the adjustment knob #5 to the tower #1.

**E** Attach the accessory tray #9 with the screws #8 and the panel #6 with the screws #7 to the cabinet #2.

**F** Attach the swing arm #20 to the column #1 with the screw #15 and washer #12, #13, #14. Tighten nut #10 and washer #11.

### IMPORTANT!

**THE WASHERS #12, #13 (Fig.5) MUST BE PROPERLY IN PLACE.**

**G** Check the swing arm #20. If it is too tight, just release nut #10 (Fig.5), release the screw slightly #15 and tighten the nut #10 again. Repeat the check.

### IMPORTANT!

**THE ARM #20 SHOULD SWING FREELY BUT THERE SHOULD BE NO PLAY UP AND DOWN.**

**H** Attach the vertical slide #19 to the swing arm #20 with the spring #18 and plug #17.

If the bead breaker is attached disregard this paragraph.

**I** Place the bead breaker arm #1 (Fig.9) inside arm support #4. Holes #5 for the arm and arm support must match.

Grease pin #6. Lock arm #1 to arm support #4 with pin #6 and ring #7.

**L** Attach spring #3 to the hook on the frame and attach it to hook #2 on bead breaker arm.

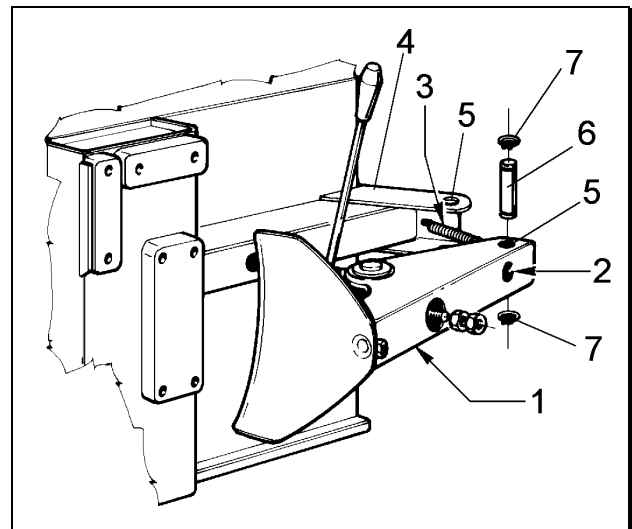

Fig.9

**M** Securing the tire changer to the floor is not required but it is suggested.

### 2.1 ELECTRICAL INSTALLATION

**WARNING!**  
**THE ELECTRICAL INSTALLATION MUST BE MADE BY A LICENSED ELECTRICIAN.**

Check that the electrical specifications of the power source are the same of the machine. The machine uses 0.75 kW.

Electric specifications are clearly marked on a label at the end of the electric cord.

If the plug is provided disregard this paragraph. Connect the electric cord of the machine with an approved plug. The ground cable (green and yellow) must be properly connected.

**WARNING!**  
**FAILURE TO PROVIDE PROPER ELECTRICAL SUPPLY AND GROUNDING WILL CREATE A SHOCK HAZARD TO THE OPERATOR.**



### 2.2 AIR INSTALLATION

**WARNING!**  
**THE AIR INSTALLATION MUST BE MADE ONLY BY LICENSED PERSONNEL.**

**WARNING!**  
**EXCESSIVE AIR PRESSURE CAN SERIOUSLY INJURE PERSONNEL AND DAMAGE THE MACHINE.**

Ensure that the line pressure is within the limits required by the machine. If the pressure exceeds 170 psi (12 bar) it is mandatory to install a pressure regulator before the air inlet of the machine.

If the air pressure is lower than the minimum required of 110 psi (8 bar) the clamping power of the turntable and the bead breaker power may be insufficient for certain tires.

It is suggested that the air supply be equipped with a water separator and air lubricator.

After ensuring all the above proceed as follows:

**A.** Connect the machine to the air supply with a rubber hose (rated for the pressure) with an internal diameter of no less than 1/4" (6mm).

**WARNING!**  
**BEFORE CONNECTING THE MACHINE TO THE AIR SUPPLY BE SURE ALL PERSONNEL ARE CLEAR OF THE MACHINE AND THAT NOTHING IS LEFT ON THE TURNTABLE AREA (TOOLS)**

**B.** Should you install any optional accessories, please refer to the relevant instructions.

**C.** Should an air lubricator be installed, ensure the functional ability of the unit. Follow instructions of @ 7.0.J.

**3.0 CONTROLS**

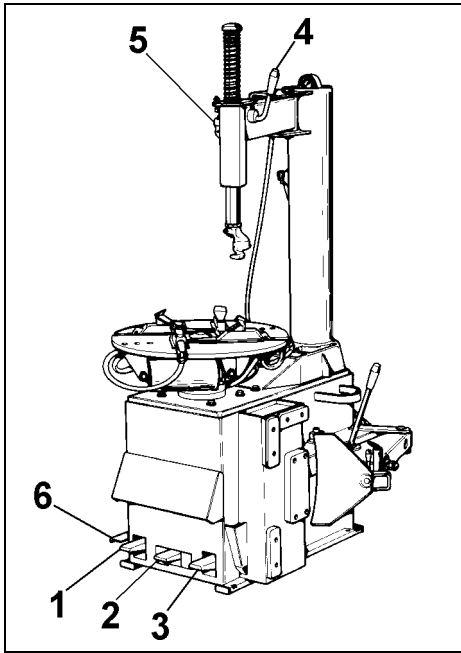

Fig.10

Before operating the machine, take the time to familiarize yourself with the operation and function of all the controls.

**A** Press down and release the first pedal from the left: the jaws of the turntable will retract.  
 Do it again: the jaws will expand.  
 If you press the pedal prior to the end of the stroke and release, the jaws may be stopped in any position.

**B** Open the bead breaker arm.  
 Press down and hold the second pedal from the left: by doing this you operate the bead breaker blade and the arm will move towards the machine.  
 Release the pedal: the bead breaker blade will retract.

**C** Press down the first pedal from the right: the turntable turns clockwise.  
 Lift the pedal and the turntable turns counter-clockwise.

**D** Lower the lock handle (#4 Fig.10) to unlock the vertical slide, lift the handle to lock.

**E** Turn adjustment knob (#5 Fig.10) for positioning mount/demount head to rim diameter.

**F** Press bead-seater pedal on left side of the machine (#6 Fig.10) half way down: air will come out from inflation hose end.

**G** Press bead-seater pedal down swiftly to get air blast from the inflator jets on the jaws.  
 Air simultaneously comes out of inflator hose.

**ATTENTION!**  
**WHEN OPERATING THE BEAD SEATER IT IS MANDATORY TO WEAR SAFETY GLASSES TO PROTECT EYES.**

**WARNING!**  
**WATCH YOUR FINGERS AND LEGS!**

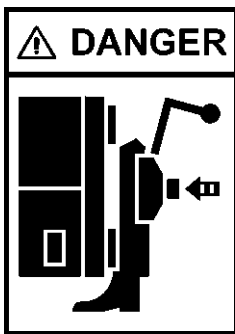

541

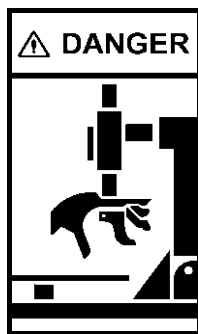

542

**4.0 MOUNTING AND DEMOUNTING PRECAUTIONS**

**IMPORTANT!**

**BEFORE MOUNTING A TIRE ON A RIM, PAY ATTENTION TO THE FOLLOWING:**

**A. THE RIM MUST BE CLEAN AND IN GOOD CONDITION: IF NECESSARY CLEAN AND PAINT IT AFTER REMOVING ALL WHEEL-WEIGHTS TO INCLUDE 'TAPE WEIGHTS' INSIDE THE RIM.**

**B. THE TIRE MUST BE CLEAN AND DRY, WITHOUT ANY DAMAGE TO THE BEAD.**

**C. REPLACE THE RUBBER VALVE STEM WITH A NEW ONE OR REPLACE THE 'O' RING IF THE VALVE STEM IS MADE OF METAL.**

**D. IF THE TIRE REQUIRES A TUBE, MAKE SURE THE TUBE IS DRY AND IN GOOD CONDITION.**

**E. LUBRICATION IS NECESSARY TO MOUNT THE TIRE CORRECTLY AND GET A PROPER CENTERING. BE SURE YOU ARE USING APPROVED LUBRICANT ONLY.**

**F. MAKE SURE THE TIRE IS THE CORRECT SIZE FOR THE RIM.**

**4.1 DEMOUNTING TUBELESS TIRES**

**A.** Remove all wheel-weights from the rim. Remove the valve stem or core and deflate the tire (Fig.11).

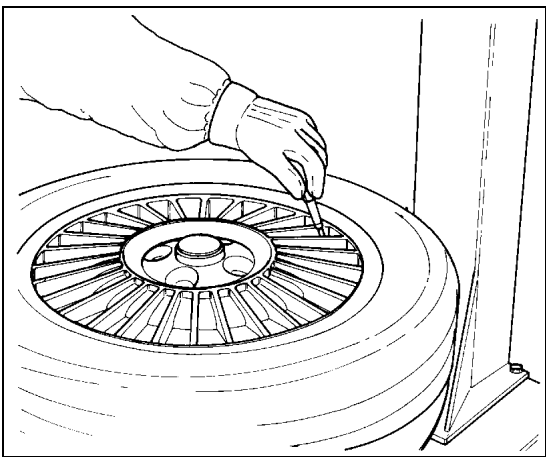

Fig.11

**B.** Break both beads. Pay extra attention during this operation as it is easy to mistakenly keep your foot on the bead breaking pedal too long. This could result in immediate bead damage (Fig.12)

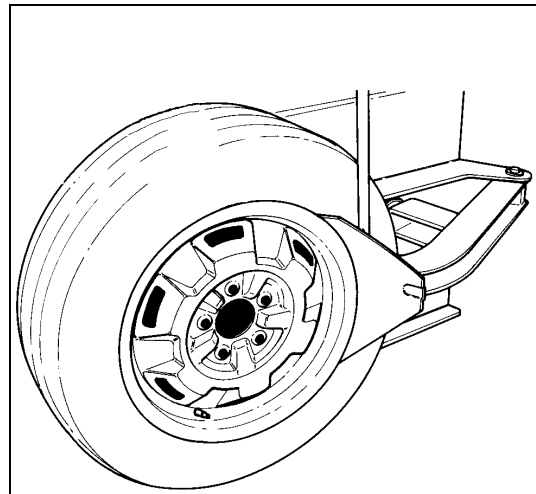

Fig.12

**WARNING!**  
ON CHEVROLET CORVETTE WHEELS WITH THE OPTIONAL LOW PRESSURE SENSOR INSTALLED, BREAK THE BEAD AT 90 DEGREES OFFSET FROM THE VALVE STEM. DAMAGE TO THE WHEEL WILL RESULT IF THE BEAD IS BROKEN AT ANY OTHER POINT ON THE RIM.

**C.** Set the rim clamps to the proper position: retract **clamps** to clamp the wheel from the inside and expand **clamps** to clamp from the outside. When clamping small wheels (14" or smaller) from the outside, set the clamps at a diameter nearly equal to the rim diameter, before placing the wheel on the clamps. This will help avoid the possibility of pinching the tire.

**WARNING!**  
TO MINIMIZE THE RISK OF SCRATCHING ALLOY RIMS, THESE SHOULD BE CLAMPED FROM THE OUTSIDE.

**D.** Liberally lubricate both beads. Place the wheel **WITH DROP CENTER UP** (Fig.13) on the turntable, and clamp in position. Hold the tire and wheel down while clamping.

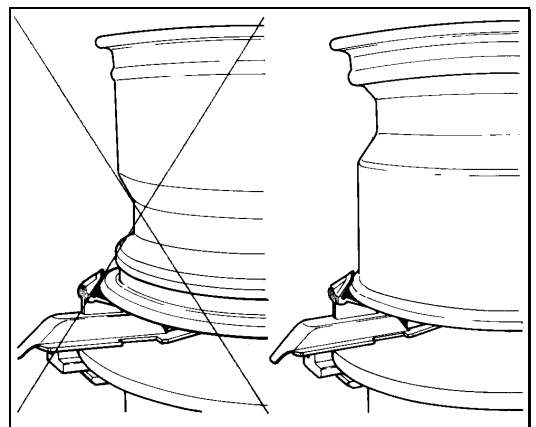

Fig.13

**E.** Position the mount/demount head in contact with rim edge and lock it into place: the tool automatically moves away from the rim edge vertically. Turn the adjustment knob until the mount/demount head clears from the rim flange about 1/16" (2mm): this is necessary to avoid any rim damage (Fig. 14).

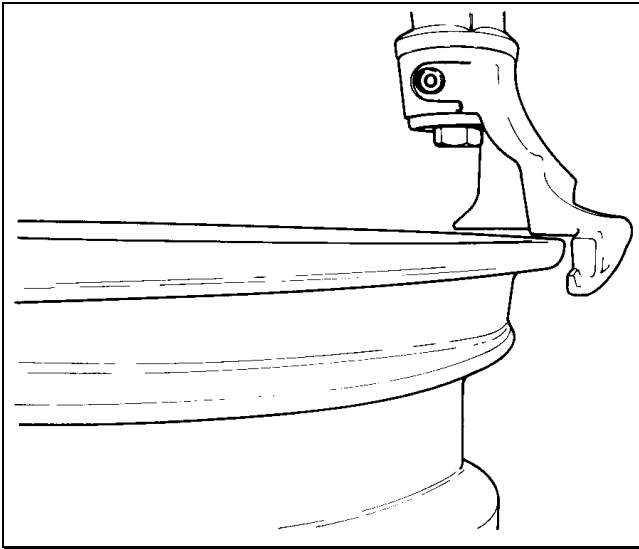

Fig. 14

**NOTE:**

**THE ROLLER INSIDE THE MOUNT/DEMOUNT TOOL MAY BE REPLACED BY A PLASTIC INSERT. REPLACEMENT IS SUGGESTED FOR OPERATORS MAINLY WORKING ON LIGHT ALLOY RIMS.**

**EVERY MACHINE IS EQUIPPED WITH SEVERAL PLASTIC INSERTS (INSIDE STANDARD EQUIPMENT BOX). THE PLASTIC INSERTS WILL HELP AVOID DAMAGE FROM ACCIDENT CONTACT BETWEEN THE TOOL AND THE RIM. THE PLASTIC INSERTS MUST BE PERIODICALLY REPLACED.**

**NOTE:**

**ONCE THE MOUNT/DEMOUNT HEAD IS POSITIONED PROPERLY, MATCHING WHEELS MAY BE CHANGED WITHOUT HAVING TO RESET THE HEAD.**

**F.** Insert the bead lifting tool under the bead and over the support of the mount/demount tool. Lift the bead onto the mounting.

To make this operation easier, insure that the bead of the tire, directly across from the mount/demount head, is in the drop center of the wheel. Push the tire into the drop center with your hand or bead depressor tool if necessary.

If desired, the bead lifting tool can be removed after lifting the bead onto the finger (Fig. 15).

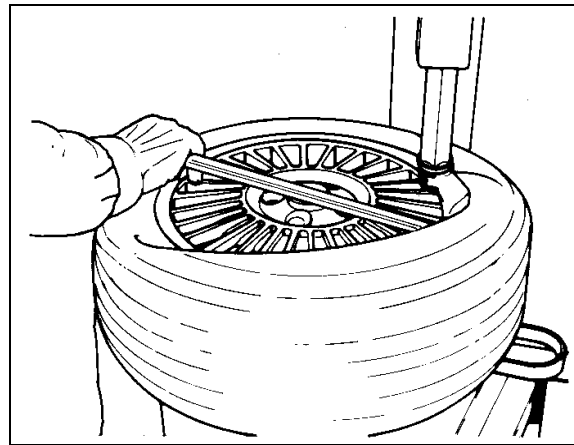

Fig. 15

**G.** Rotate the turntable clockwise and at the same time push down on the tire sidewall to move the bead into the drop center of the rim (Fig. 16).

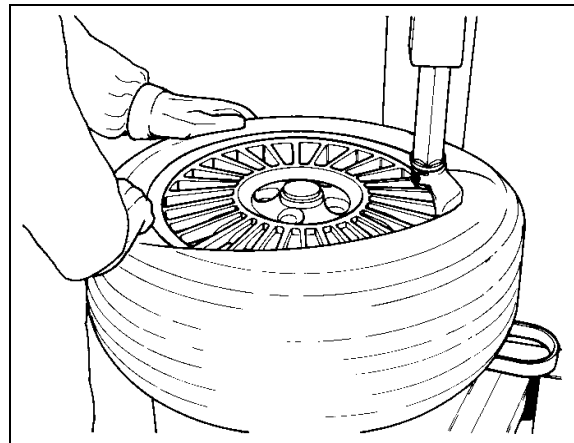

Fig. 16

**H.** Repeat the process for removing the lower bead. This time, lift the bead opposite to the mount/demount head to keep it in the drop center (Fig. 17). Move the swing arm aside and remove the tire.

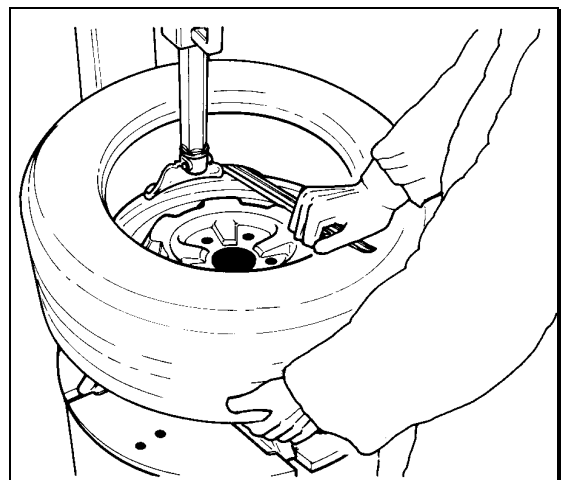

Fig. 17

## 4.2 MOUNTING TUBELESS TIRES

A. Lubricate the entire rim surface (Fig.18).

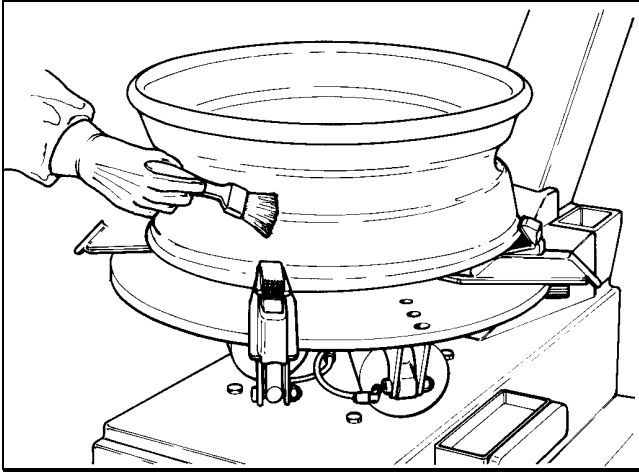

Fig.18

Liberally lubricate both beads of the tire (Fig.19).

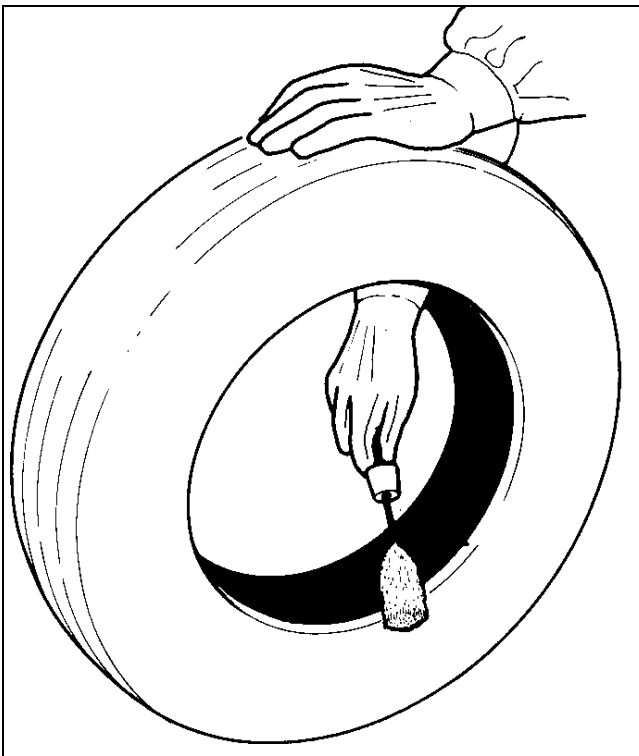

Fig.19

**WARNING!**  
 THESE LUBRICATION OPERATIONS ARE NECESSARY TO MOUNT THE TIRE CORRECTLY AND GET A PROPER CENTERING ON THE RIM. BE SURE YOU ARE USING APPROVED LUBRICANT ONLY.

**WARNING!**  
 SOME TIRES HAVE A COLOR DOT THAT MUST BE KEPT ON THE OUTSIDE OF THE WHEEL. IF THIS IS THE CASE BE SURE TO ATTAIN PROPER ALIGNMENT.

B. Lock the rim on the chuck and rotate it to have the valve at the 2 o'clock position. Place the tire to be mounted on the rim. Swing the mounting arm forward so that the mount/demount tool is in the working position. Engage the lower bead OVER the mounting wing and UNDER the mounting finger of the mounting tool. Turn the wheel clockwise and push the tire down into the drop center, opposite to the mount/demount head (Fig.20).

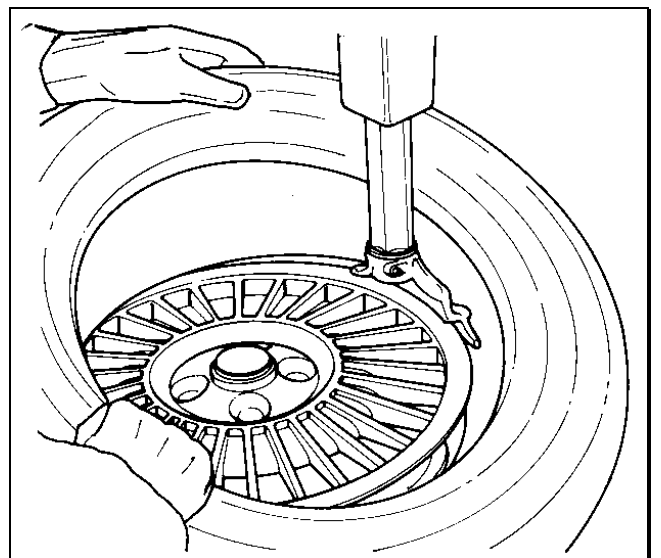

Fig.20

C. Mount the upper bead following the directions in section B. With low profile tires the bead depressor tool (option #4003444 Fig.21) can help to ease the mounting of the top bead.

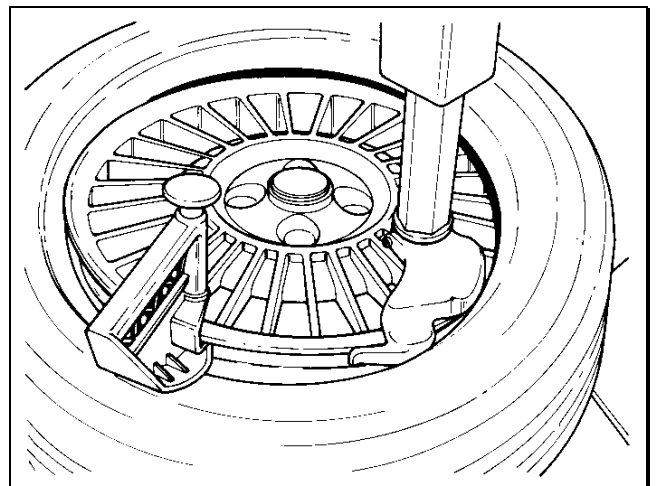

Fig.21

### 4.3 INFLATION OF TUBELESS TIRES.

Make sure that both beads are properly lubricated.

**WARNING!**  
**BEAD SEATING IS THE MOST DANGEROUS PART OF MOUNTING A TIRE.**  
 IT IS POSSIBLE TO MOUNT TIRES THAT ARE 1/2" SMALLER IN DIAMETER THAN THE RIM THAT THEY ARE MOUNTED ON. WHILE THESE BEADS WILL SEAL, IT IS IMPOSSIBLE TO GET THEM TO SEAT IN THEIR PROPER POSITION. EXPLOSION OF A TIRE MAY CAUSE SEVERE INJURY OR DEATH.

Inflate tire according to manufacturers recommendations.

**WARNING!**  
**NEVER EXCEED THE MAXIMUM PRESSURE ALLOWED BY THE TIRE MANUFACTURER.**

**THE RIM MUST BE UNCLAMPED WHEN INFLATING BUT ONLY AFTER THE BEADS HAVE BEEN SEATED.**

**THE OPERATOR MUST STAND CLEAR FROM THE WHEEL WHEN INFLATING, AND PRESSURE MUST BE MONITORED FREQUENTLY TO AVOID OVER INFLATION.**

**BEFORE INFLATING A TIRE, CHECK THE CONDITION OF THE TIRE AND THE RIM.**

Due to unusual configurations or the stacking of tires the inflation process is sometimes difficult. To assist with this problem the ACCU Model 4502 is equipped with bead seater jets incorporated into the table top.

To utilize the bead seater proceed as follows:

**A.** If possible lock the wheel from inside. Outside locking reduces efficiency.

**B.** Connect the inflation hose to the valve stem.

**C.** Lift the tire with both hands so that the upper bead is sealed to the rim edge (Fig.22).



Fig.22

**D.** Press the inflation pedal down swiftly (#14 Fig.1). The top bead is already sealed by the lifting motion. Therefore, the air from the bead seater jets will impact the top sidewall and rebound into the bottom sidewall driving it into place and creating a seal.

**ATTENTION!**  
**WHEN OPERATING THE BEAD SEATER WEAR SAFETY ATTIRE TO AVOID INJURY TO BODY OR EYES.**

**E.** Complete inflation as described at @4.3.A.

**5.0 DEMOUNTING TUBE-TYPE TIRES**

**A.** For breaking the bead operate as described for the tubeless tires in @ 4.1.A to 4.1.F.

In this case the valve is part of the tube.

**WARNING!**  
**BE CAREFUL NOT TO DAMAGE THE TUBE DURING THE BEAD-BREAKING OPERATION.**  
**THE VALVE SHOULD BE OPPOSITE TO THE BLADE OF THE BEAD BREAKER.**

**B.** To demount the first bead, place the valve at 2 o'clock position.

**WARNING!**  
**DO NOT CATCH THE TUBE WITH THE BEAD LIFTING TOOL, WHEN LIFTING THE BEAD ON THE MOUNTING FINGER.**

After demounting the first bead remove the tube before demounting the second bead, as described in @ 4.1.

**5.1 MOUNTING TUBE-TYPE TIRES**

**A.** Do as described in @ 4.2.A.  
 Do **NOT** lubricate the tube. Talc can be used to assist with tire positioning.

**B.** Confirm that the tube is designed for tires(Fig.23).

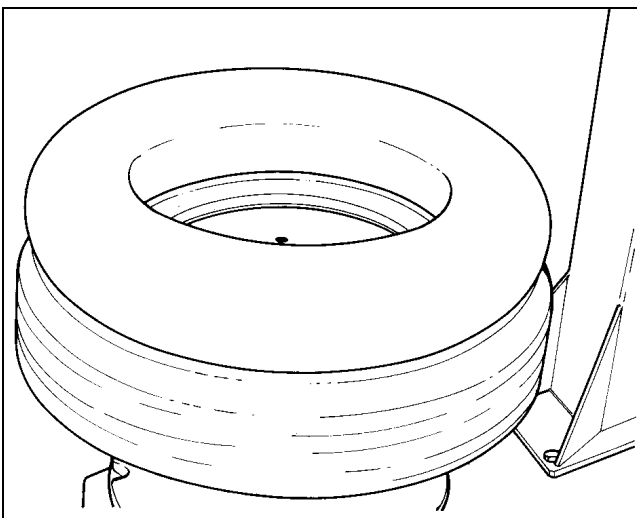

Fig.23

**C.** Inflate the tube slightly: if held with the indexfinger it should bend a little (Fig.24).

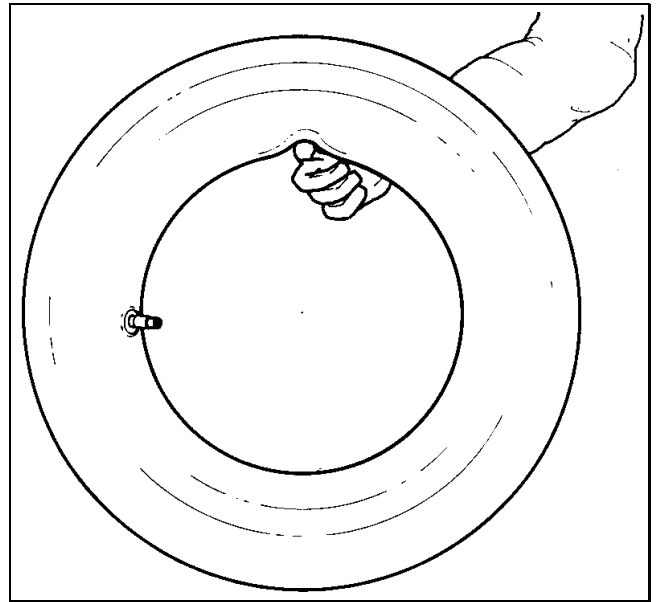

Fig.24

**D.** Mount the first bead as described in @ 4.2.B.  
 Put the tube inside the tire and hang the valve with the clip of the inflating hose (Fig.25).  
 Mount the top bead following the directions above.

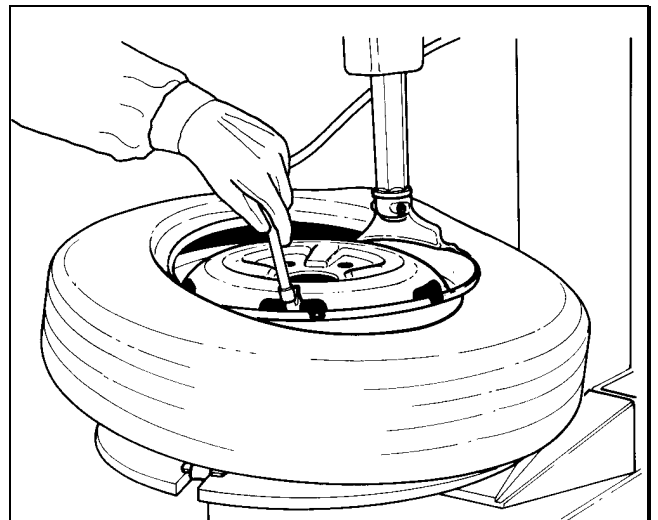

Fig.25

**5.2 INFLATING TUBE-TYPE TIRES.**

To inflate the tire unlock the rim and start inflating while pressing the valve towards the inside (this is necessary to avoid air pockets forming between tube and the tire) (Fig.26).

Ensure that the tire is correctly centered on the rim and complete inflation as described in @ 4.3.A.

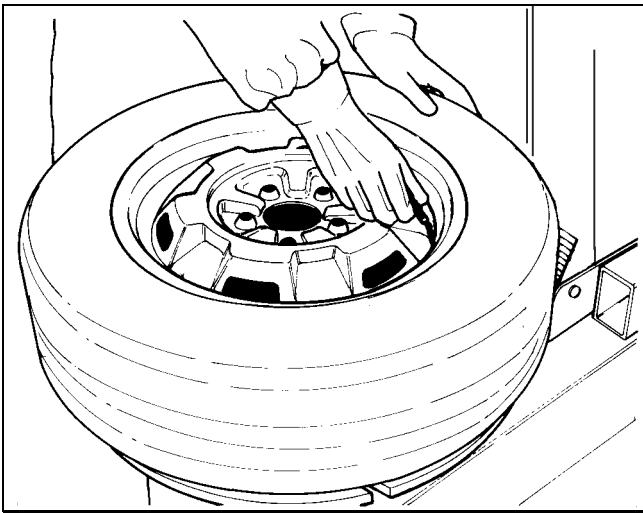

Fig.26

**6.0 MOUNTING AND DEMOUNTING MOTORCYCLE TIRES**

To mount and demount motorcycle tires it is necessary to utilize the optional motorcycle adaptors (4 pieces #4015099).

The bead-breaking, mounting and demounting technique is the same as per the car, tubeless or tube-type tires.

**WARNING!**  
**MOTORCYCLE RIMS MUST ALWAYS BE CLAMPED FROM THE OUTSIDE.**  
**AIR PRESSURE MUST NOT EXCEED 110 PSI (8 BAR) WHEN CLAMPING MOTORCYCLE RIMS.**  
**IF NECESSARY INSTALL A PRESSURE REGULATION DEVICE (OPTION #4019671).**

**7.0 MAINTENANCE**

**WARNING!**  
**BEFORE STARTING ANY MAINTENANCE OPERATION ENSURE THAT THE MACHINE IS DISCONNECTED FROM THE AIR AND ELECTRIC SUPPLY.**

**A.** Periodically clean the vertical hexagonal rod with nonflammable liquid detergent. After this immediately lubricate with oil (Fig.27).

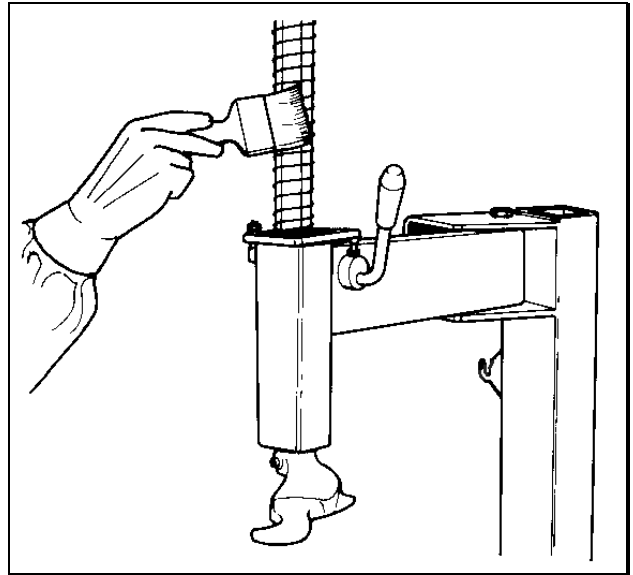

Fig.27

**B.** Periodically clean all moving metal parts and lubricate with oil.

**C.** Clean every week the teeth of the clamps with a wire brush, check the plastic rim protector and replace it if worn (Fig.28).

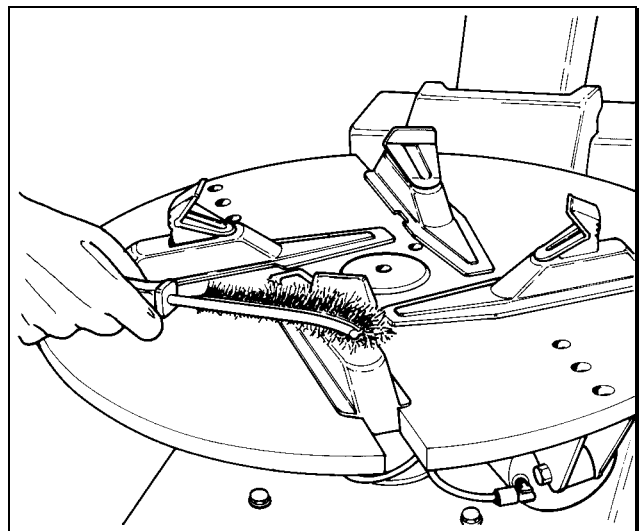

Fig.28

**D.** Periodically replaced the plastic insert inside mount/demount tool.

**E.** Lubricate rods of air cylinders with oil as needed.

**F.** Periodically wash all plastic parts with cold water and soap or window cleaner.

**G.** Check the bead breaker pads. Replace if worn.

**H.** If the machine is equipped with an air filter, discharge the water every day.

**I.** If the machine is equipped with an automatic air lubricator, check the oil level weekly. When adding oil to the lubricator, disconnect the air supply first, remove the fill screw 'A', and add oil as needed. Make sure seals are in place when replacing the cap. Drain water daily from water separator. Do this by pulling down the fitting 'B' (Fig.29).

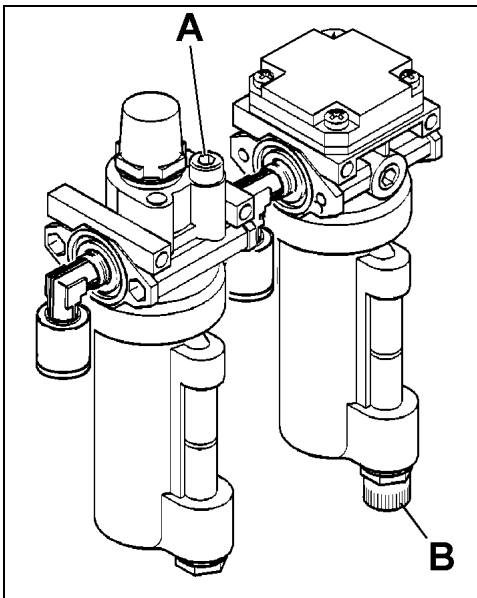

Fig.29

**WARNING!**  
**USE ONLY OILS FOR AIR DEVICES, DO NOT USE BRAKE FLUID OR OTHER NON SUGGESTED LUBRICANTS.**

Suggested oils for the filter/lubricator unit:

TAMOIL:	WHITE MINERAL OIL 15
SHELL:	ONDINA OIL 15
BP:	ENERGOL WT 3
TOTAL:	LOBELIA SB 15
ESSO:	MARCOL 82

**L.** If the machine is not equipped with an automatic lubricator, perform the following once a month.

- \* Disconnect machine from the air supply.
- \* Open the lubrication cap and drop a small quantity of oil (2-3 cc) (Fig.30). Use suggested oils listed above.
- \* Close the oil cap and tighten firmly.
- \* Connect the machine to the air supply and operate both the turntable clamping and bead breaker several times.

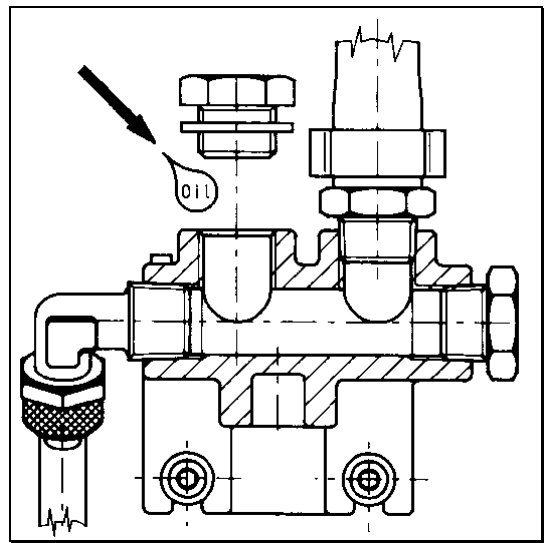

Fig.30

**K.** Drain water daily from the tank (Fig.31).

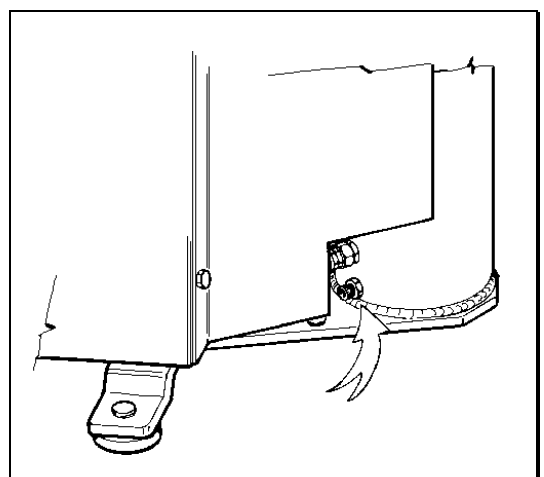

Fig.31