

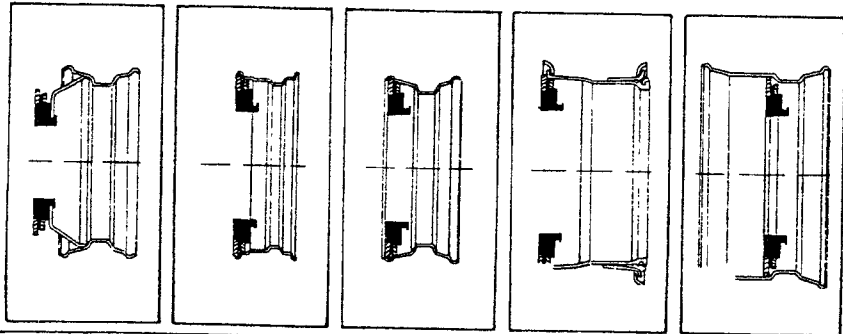

ACCU model 4440

**ELECTRIC-HYDRAULIC TIRE
CHANGER FOR MEDIUM
AND LARGE SIZE TIRES.**

**OPERATOR'S MANUAL
SPARE PARTS EXPLODED VIEWS**

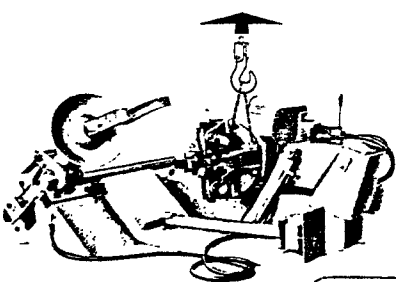
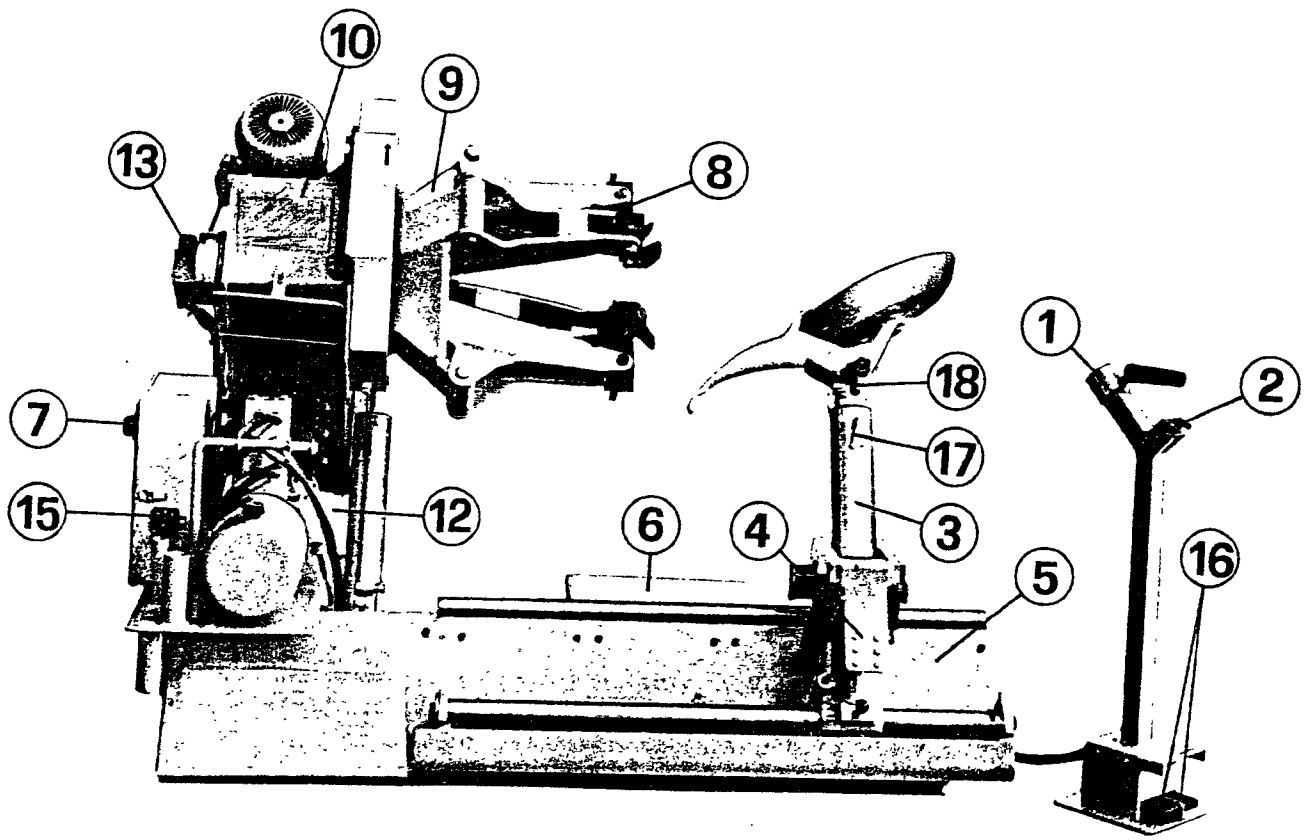

INTRODUCTION

ACCU 4440 is a universal electric-hydraulic tire changer for large and medium sized tires. It operates with the wheel in a vertical position considerably reducing operator effort.

The **ACCU 4440** is equipped with a truly universal, automatically self-centering chuck, that can operate on even rim or wheel (drop center, tubeless, 2-5 pieces lock rings) between 14" and 44" without using extension adapters. **ACCU 4440** operates quickly and easily on tires up to 79" (mm. 2000) diameter by 39.5" (mm. 1000) or more wide. The locking force of the chuck is controlled by an adjustable pressure reduction unit. The chuck can be operated both clockwise and counter-clockwise at two different speeds. Opening and closing of the four chuck arms is hydraulically controlled for precise adjustment. The toolholder-carrier (here after referred to as TC) is moved into working position hydraulically. The **ACCU 4440** can be operated from any location around the machine (even clamping and unclamping) by using its light easily portable control unit.

INSTALLATION

MOVING THE MACHINE

Completely close the chuck by moving switch (Fig. A §2). Place chuck arm (Fig. A §10) to idle position (all the way down) and move the TC (Fig. A §5) as close to the inside (toward chuck) of the machine as possible by moving control switch (Fig. A §1). A chuck arm is a good lifting point for sling or chain (Fig. B).

ELECTRICAL SUPPLY

WARNING!

**ELECTRIC INSTALLATION MUST BE MADE BY A LICENSED ELECTRICIAN ONLY!
THE MACHINE MUST BE BOLTED TO THE FLOOR.**

Make sure that your line voltage and phase is the same as requested by the machine. Turn machine on by using on-off switch (Fig. A §7) and check rotation of the hydraulic pump motor (Fig. A §12, see arrow). If the rotation is not the same direction as the arrow, reverse the rotating direction by reversing any two live wires on the plug. Before dismounting or mounting any tires, familiarize yourself with the **ACCU 4440** operation:

1. Turn on machine (switch Fig. A §7).
2. Choose rotation speed of chuck: §1 slow, §2 fast (Fig. A §15).
3. Set clamping pressure (1 to 9) on pressure regulator (Fig. A §13). This setting should remain on 9 unless working with light section steel or aluminium wheels.
4. To raise the chuck arm (Fig. A §10), move 4-way switch (Fig. A §1) towards the handle.
5. To lower the chuck arm, move the 4-way switch away from the handle.
6. To open or close chuck jaws, use switch (Fig. A §2).
7. To move the toolholder-carrier (TC) inward move 4-way switch (Fig. A §1) to the left.
8. To move the TC out, move 4-way switch to the right.
9. To rotate the chuck, press either pedal (depending upon required rotation) on the control unit (Fig. A §16).
10. To release toolholder, depress pedal (Fig. A §4).
11. To lift toolholder to idle position, pull on lock pin (Fig. A §17).
12. To rotate tools (disc/hook) remove pin (Fig. A §17).
13. To lock disc (special application only), place lock pin into hole (Fig. A §18).

WARNING!

STANDING OF ANY PERSON IN FRONT OF THE WHEEL WHEN MOUNTING/DISMOUNTING MUST BE FORBIDDEN!

OPERATION

Before operating, lift toolholder (Fig. A §3) to idle position by pushing on release pedal (Fig. A §4)

CLAMPING

Depending on rim configuration (see examples in Fig. C). Use the control switch (Fig. A §1) to move the TC ramp (Fig. A §6) towards the outside (away from self-centering chuck). Place tire in a vertical position and roll onto the TC ramp. Close the chuck jaws (Fig. A §8) by using control switch (Fig. A §2) and adjust the chuck in the center of the wheel/rim by moving it up or down depending upon wheel or rim size (use 4-way control switch for these operations). Slowly move the TC ramp in or out and the chuck up or down and open the chuck arms until rim is properly locked. When working with thin and/or weak rims (eg. farm rims) adjust pressure regulator unit (Fig. A §13) to decrease locking pressure.

NOTE: It is very important to well lubricate both bead and rim in all mounting and demounting operations.

SECTION 1: DISMOUNTING AND MOUNTING OF RADIAL TUBELESS TIRES (For Bias-ply tubeless tires see Section 3)

NOTE

Never insert pin in hole (Fig. D §3). Pin is used only during a very specified operation occurring when dismantling lock ring tires. See Section 2.

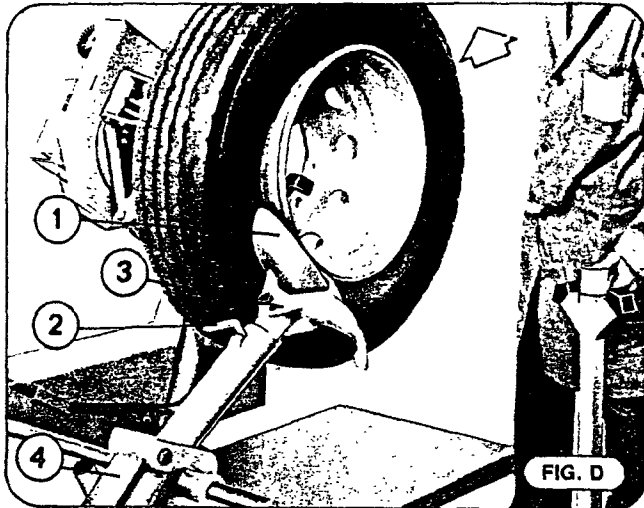

DISMOUNTING

Place the bead breaker tool 'disc' or 'roller' as shown in Fig. D and lock in place with pin (Fig. D §2).

Move the chuck up or down and the TC in or out so that the bead breaker tool is approximately 1/2" below the rim. While rotating the chuck counter-clockwise, move the TC into the tire to break the bead. After breaking the bead, continue to rotate the chuck while applying lubricant to the bead and rim (you can never use too much lubricant). Lift toolholder to idle position by pushing on release pedal (Fig. D §4). Remove pin (Fig. D §2), rotate tool 180° and lock

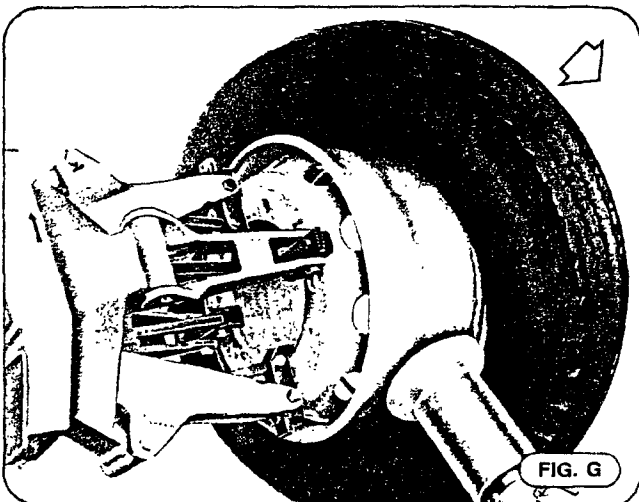
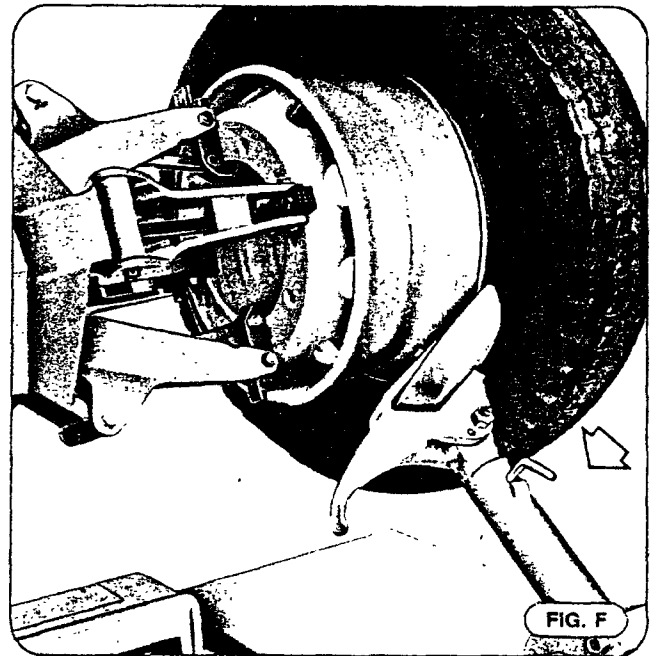
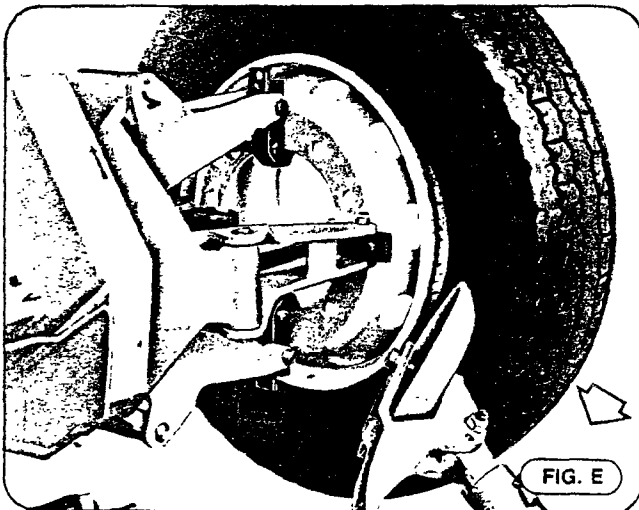

with pin. Repeat the above operation to break the inner bead and lubricate (Fig. E). Continue to move the TC out while rotating the chuck until both beads have come completely off and the tire is dismantled (Fig. F). All of these operations can be even more easily done by using the special tubeless roller (Fig. G).

MOUNTING

Screw the mounting clamp (Fig. J §1) onto the edge of the rim with valve stem at 7 O' clock and the clamp at 6 O' clock. Place the tire in a vertical position next to the rim. While holding the tire in this position, rotate the chuck clockwise lift the tire. Make sure both beads slip over the clamp tool (this is easier if you guide the tire bead onto the clamp with slight pressure from your hand Fig. J). Stop the chuck with the clamp tool at 11 O' clock. For larger size tires install clamp same as above then rotate the chuck until clamp is at 12 O' clock position with the chuck arm lowered. Place the tire in a vertical position next to the rim. Lean the tire beads (or bead when mounting one bead at a time) over the mounting clamp and use the chuck arm to raise the assembly to working height while rotating the chuck to position the clamp 11 O' clock.

Place tool (disc, hook or roller) near the edge of the rim (approximately 1/4" below and 1/2" inside rim flange when using hook or 1/2" below and 1" inside when using disc/roller). Rotate chuck until the tire is fully mounted (Fig. J1).

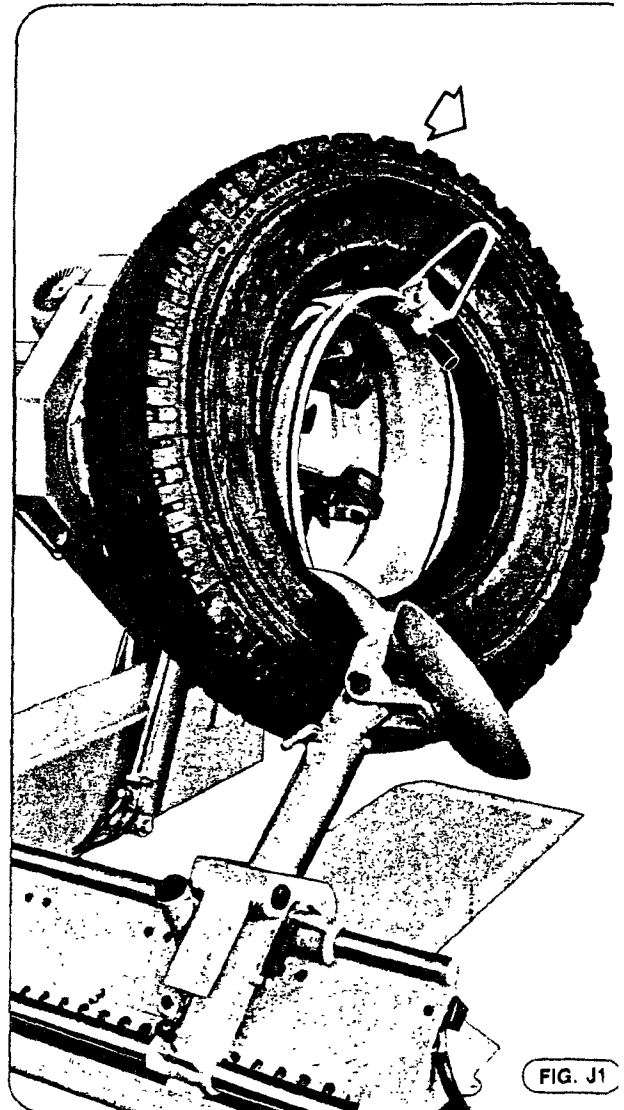
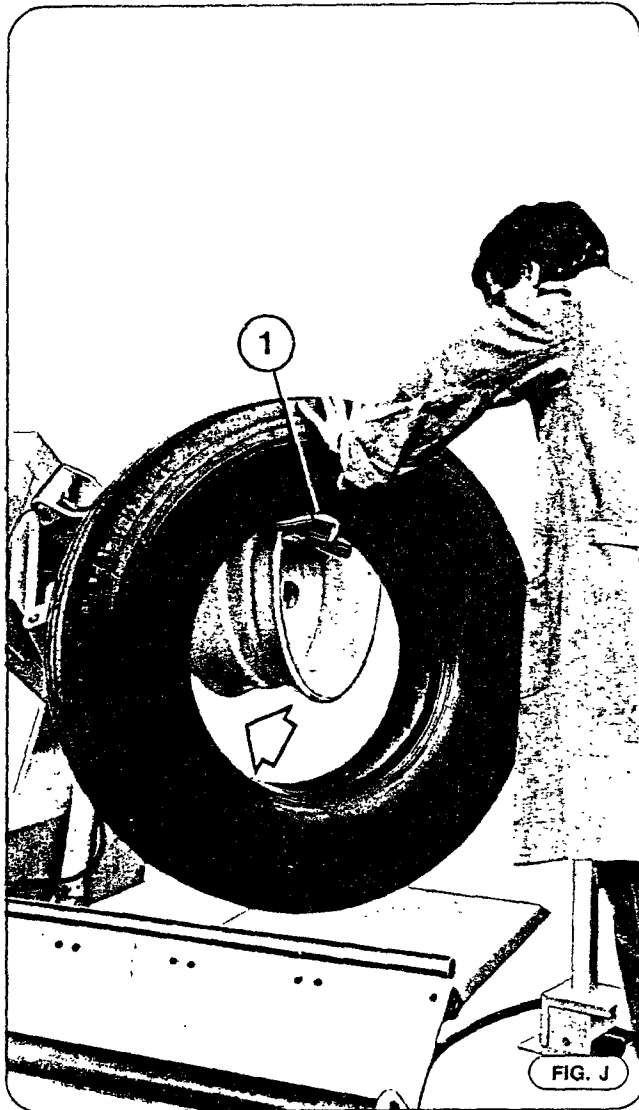

SECTION 2: DISMOUNTING AND MOUNTING, 2, 3 OR 5 PIECE LOCK RING RIMS

DISMOUNTING

Place the bead breaker tool 'disc' near to the rim as shown in Fig. H.

When being flange firmly sticking to the tire: lock it to the rim with special clamp (Fig. H §1) to break the bead. This mostly occurring with off-road tires.

While rotating the chuck counter-clockwise, move the TC slowly into the tire. When past the flange, lower the chuck and push on the bead as close to the rim base as possible. The disc tool may be used to free lock ring components. To remove lock ring, release notched end from its groove with tire lever (Fig. K). Use the disc to pull lock ring out completely by rotating the chuck with the disc under lock ring in a counter-clockwise direction. Remove remaining components and lubricate rim base.

NOTE

This is the only operation during which it is necessary to lock the tool with the pin (Fig. K §1).

Repeat bead breaking operation on the inner bead (Fig. K1).

Continue to move TC out. When the valve stem approaches the disc, continue to move the TC out but reverse rotation direction of the chuck to prevent damage to the stem. Continue to operate in this manner until the tire is fully dismounted.

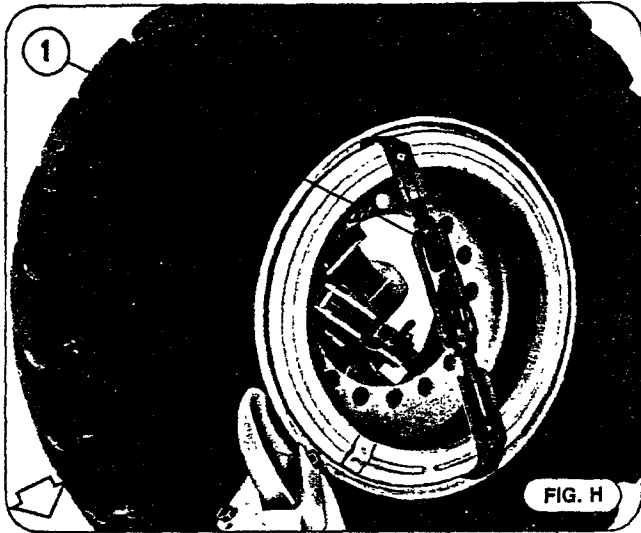

NOTE

In some case the flange is absolutely sticking to the tire and it is more convenient to dismount the tire with the flange attached. To dismount it, lock it with the chuck as if it was a common rim and break the bead as shown in Fig. L.

MOUNTING

Place the tire (with tube and flap in place) on the TC with valve stem at 6 O'clock. To put the valve stem in place, rotate and lower the chuck while adjusting the TC in or out until the stem can be pulled through the stem hole in rim. Push the

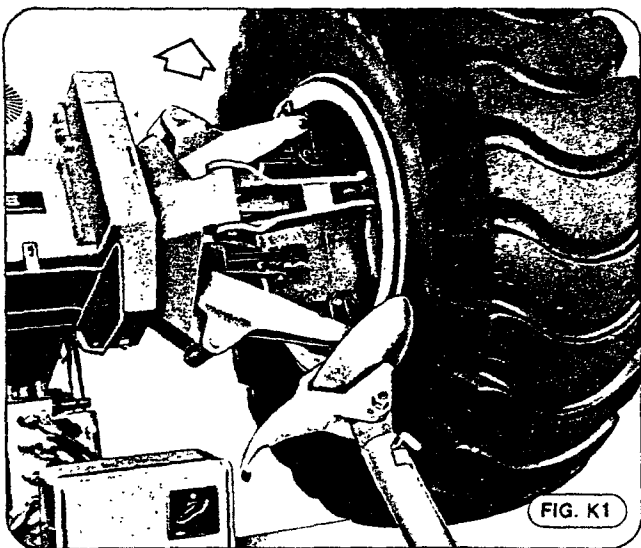

tire in place on the rim with your hand or, if working with heavy tires, use the disc tool. Mount the flange. To fix the lock ring, engage the left end into its groove at 10 O'clock. Place the disc as shown in Fig. M. Rotate the chuck clockwise while at the same time push the lock ring into the groove by moving the TC in.

WARNING!
INFLATION OF ANY KIND
OF TIRE MUST BE
CARRIED OUT IN AN
APPROVED INFLATION
CAGE

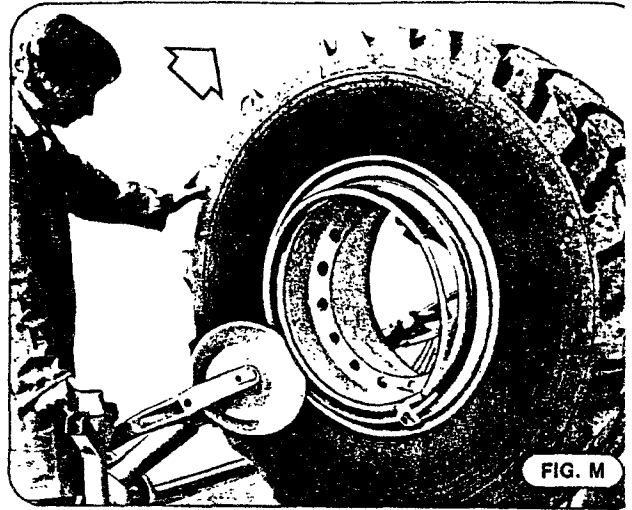

SECTION 3: DISMOUNTING
AND MOUNTING FARM,
EARTH MOVER, DUPLEX,
SKIDDER AND BIAS-PLY
TUBELESS TIRES
(One bead at a time)

NOTE:

The enclosed illustrations show farm tires but they can be used as reference when working on bias-ply tubeless, earth mover, drop center rims-duplex or super single, etc. When dismounting and mounting is very difficult because of the nature of the tire (stiff, hard, rusty, heavy, etc.) use chuck rotating speed §1. The chuck torque is considerably increased at speed §1 making it possible to overcome enormous resistance.

DISMOUNTING

Place the bead breaker tool near the rim as shown in Fig. N. While rotating the chuck counter-clockwise, move the TC slowly into the tire to break the bead. After breaking the bead, continue to rotate the chuck while applying lubricant to bead and rim. Repeat the same operation to break the inner bead and lubricate (Fig. N1).

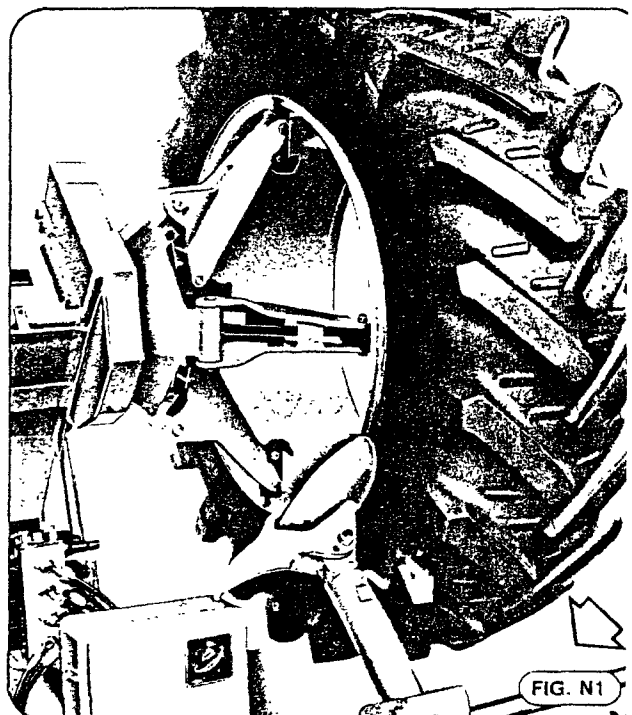
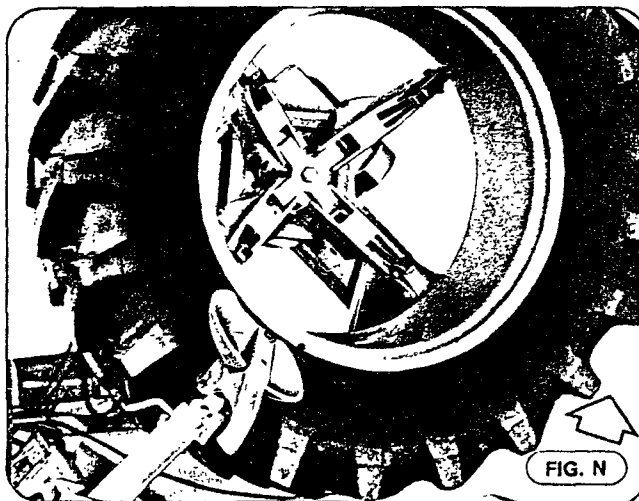

Place the hook tool as shown in Fig. P. Move the hook between rim and bead to catch outer bead. Raise the chuck a little and move TC out. Insert long lever (Fig. P §1) below the hook between rim and bead to apply a pressure on the inner tire wall.

Be sure that bead is sliding into the drop center 180° from the tools. Slowly rotate the chuck counter-clockwise until the bead has come off.

NOTE:

For tires with tube, lift toolholder to idle position and lower the chuck to press the tire on the TC ramp. Move TC and tire out making it easy to remove (or install) the tube (Fig. Q).

The second bead can be dismounted two ways depending upon size and configuration of the tire.

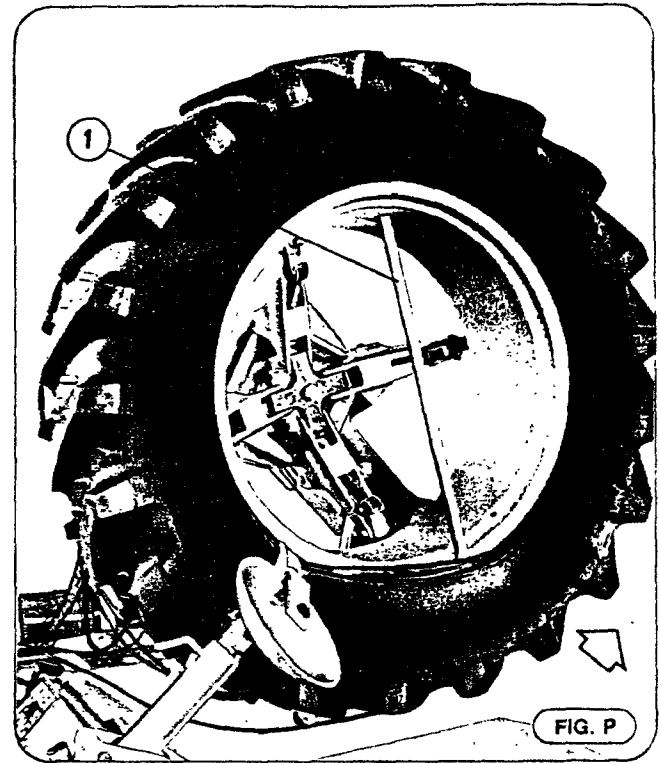
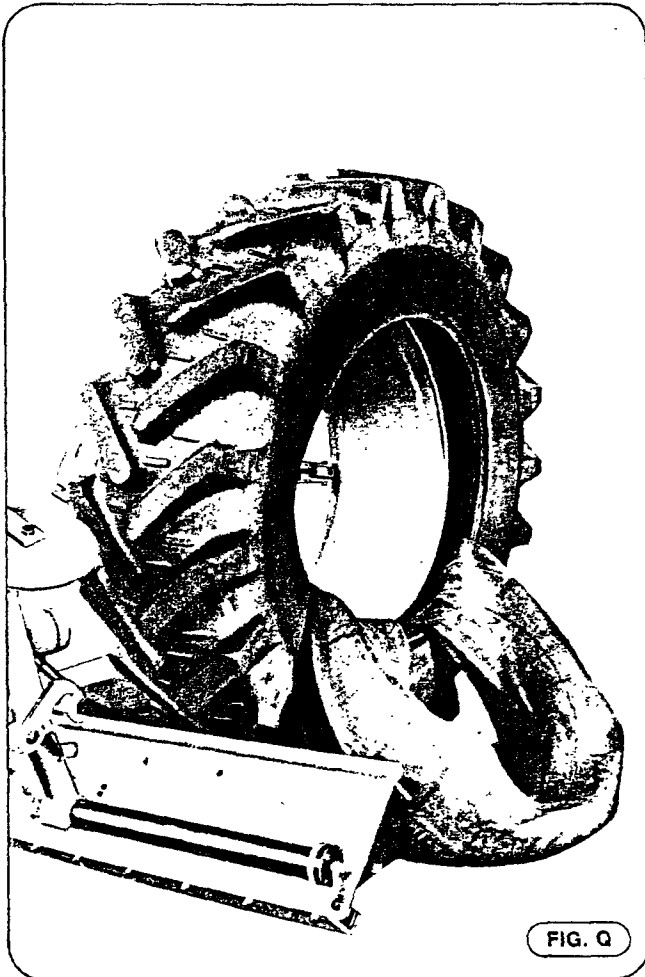

1. HOOK TOOL: Position hook tool as shown in Fig. R. Move hook between rim and bead to catch the inner bead. Raise the chuck a little and move the TC out.

§2 DISC TOOL OR ROLLER: Position disc or roller approximately 1/2" below the inside flange and move the TC outward until the disc has pushed off the second bead.

Insert long lever above hook between rim and bead to apply pressure on the outer tire wall. Be sure that the bead is sliding into the drop center 180° from tools. Slowly rotate the chuck counter clockwise until the bead has come off.

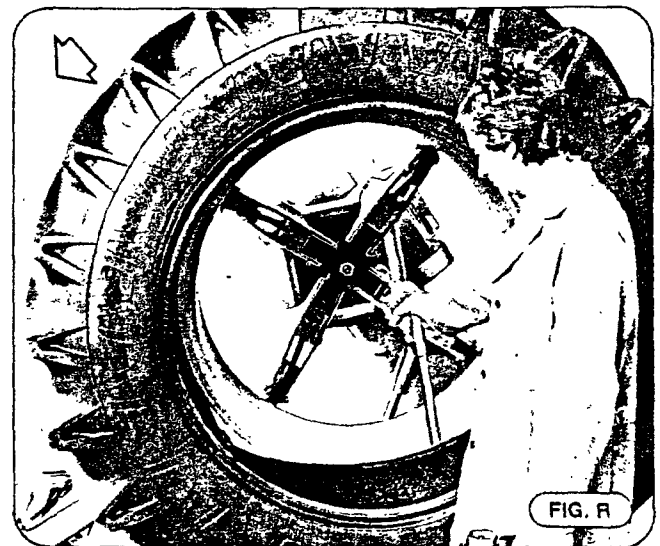

MOUNTING

Screw the mounting clamp on the edge of the rim with valve stem at 7 O' clock and clamp at 6 O' clock. Place tire in a vertical position next to the rim. While holding the tire in this position, rotate the chuck clockwise allowing the tire to be lifted with one bead over the clamp (Fig. R1). Stop the chuck with the clamp tool between 10-11 O' clock.

For large heavy tires install clamp same as above then rotate chuck until clamp is at 12 o' clock position with the chuck arm all the way down. Place the tire in a vertical position next to the rim then lean the tire bead over the mounting clamp and use the chuck arm to raise the assembly to working height, while rotating the chuck to position the clamp at 11 O' clock. Position the hook tool pointing away from the chuck and move it between the rim and the bead. When you catch the

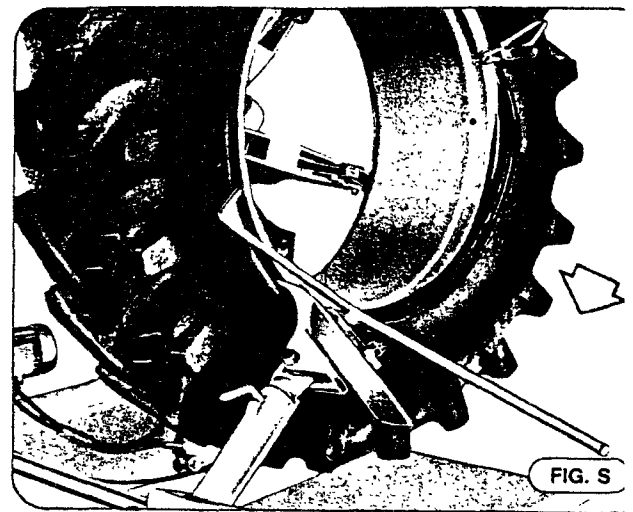
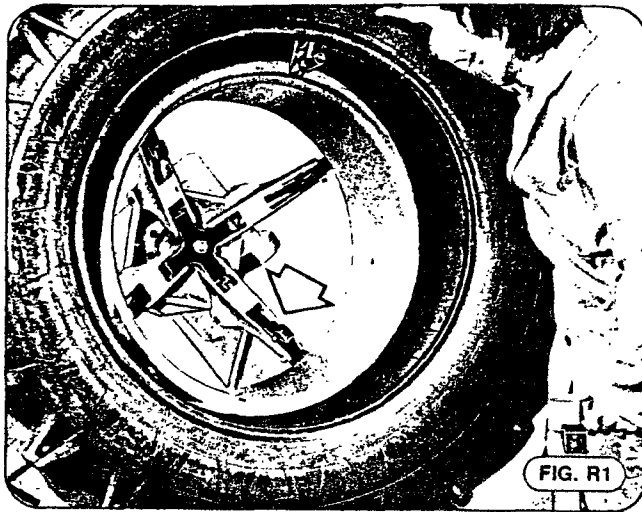

inner bead, raise the chuck a little and move the TC toward the chuck. Begin to slowly rotate the chuck clockwise until the first bead is mounted. Remove clamp from the edge of the rim. Install tube and reinstall clamp at 6 O'clock; rotate to 11 O'clock. Position the hook tool pointing towards chuck and next to the edge of the rim (approx. 1/4" below at 1/2" inside). Rotate the chuck clockwise until the tire is fully mounted. If necessary, use the special bead pushing lev (Fig. S).

For Skidder with double drop center rim, a special clamp tool is required.

MAINTENANCE

Your **ACCU 4440** is a well designed and manufactured piece of heavy duty equipment. With proper care and routine maintenance it will last a long time. We suggest that you take the time to follow this simple routine maintenance schedule for years of trouble free use.

Regularly clean and lubricate:

1. Chuck pivots- use grease fittings provided.
2. Toolholder-carrier slide shafts - through holes in carriage.
3. Movable parts (axels, arms, pivots, shafts, etc.).

Periodically:

1. Clean and check chuck jaws.
2. Check hydraulic oil levels.

NOTE: When checking hydraulic oil levels, chuck jaws must be closed and arms all the way lowered with toolholder carriage moved nearest to machine.

3. Check hydraulic fluid level - use sight gauge located below chuck
4. Hydraulic pump- use dipstick cap located on hydraulic oil reservoir.

Add oil if necessary- Recommended oils:

CHUCK		HYDRAULIC PUMP	
AGIP	Rotra Hypoid 85W/90	MOBIL	DTE oil 26
EXXON	Gear Oil GP 80W	EXXON	Tressic 68 or Nuto 68
SHELL	Spirax EP 80W/90	SHELL	Tellus oil 68
TOTAL	EP 85W/90	TOTAL	Azolla 46

TECHNICAL DATA

Weight	lbs 1708 = kg. 775	Machine depth	55" = mm. 139
Hydraulic motor 220/380 3phase	HP 1,5	Minimum machine height	27" = mm. 68
Chuck rotating motor 220 or 380 3phase		Maximum machine height	47" = mm. 120
2 speed	HP 2,0/3,0		
Chuck capacity	14" to 44"	Bead breaker power	lbs 7330 = kg. 335
Maximum tire diameter	79" = mm 2000	Maximum torque	ftxlb 2268 = kgm. 30
Maximum tire width over	39" 1/2" = mm 1000	Locking force per jaw	lbs 3300 = kg. 150
Minimum machine width	53" = mm 1350		
Maximum machine width	68" = mm 1730		

STANDARD EQUIPMENT

- 0001418 n° 1 short lever
- 4004461 n° 1 long lever
- 4009472 n° 1 mounting clamp
- 4002354 n° 1 bead pushing lever

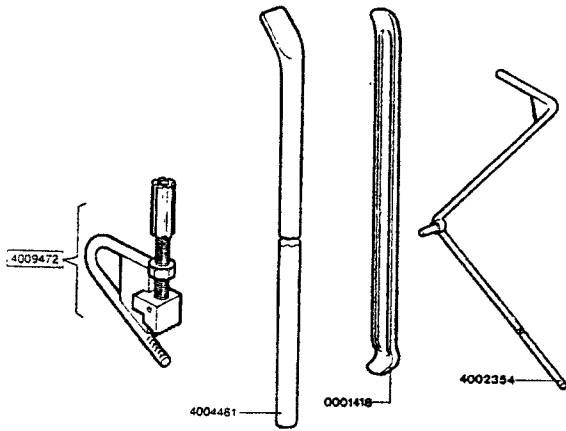

ON REQUEST

- 4007611 n° 1 O.T.R. clamp
- 4003372 n° 1 tubeless roller
- 4008257 n° 1 set of protections for ALU wheels
Ø 220-280 mm
- 4008264 n° 1 set of protections for ALU wheels
Ø 280 mm

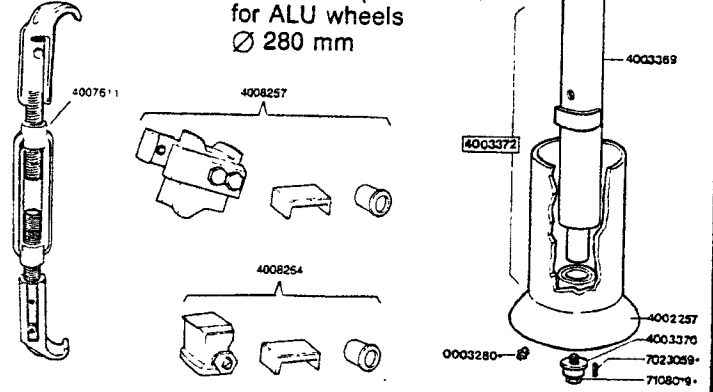

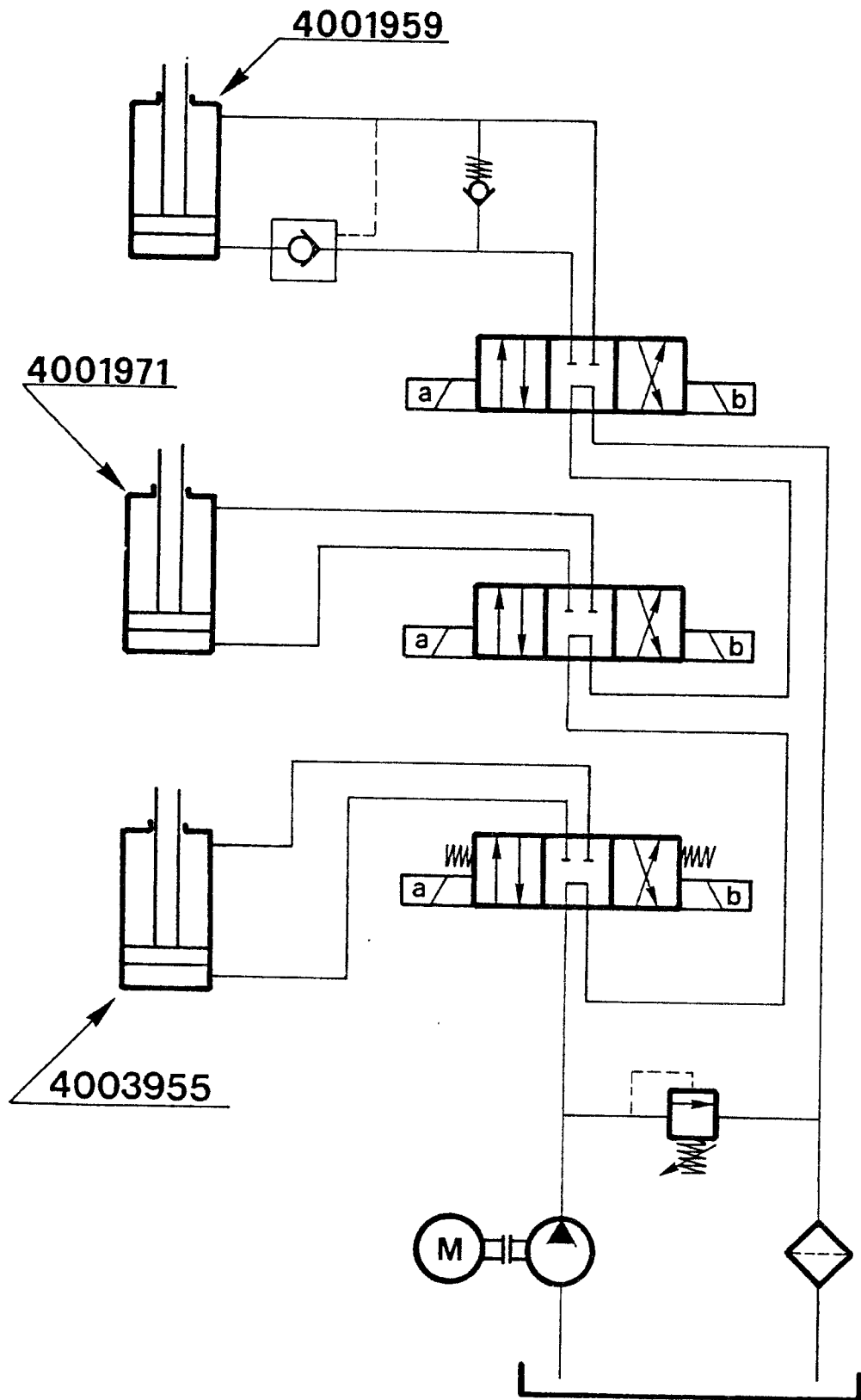

WARNING
 3 35 AT FUSES SHOULD BE MOUNTED
 ON POWER CONNECTION LINE
 BEFORE INPUT CORD.

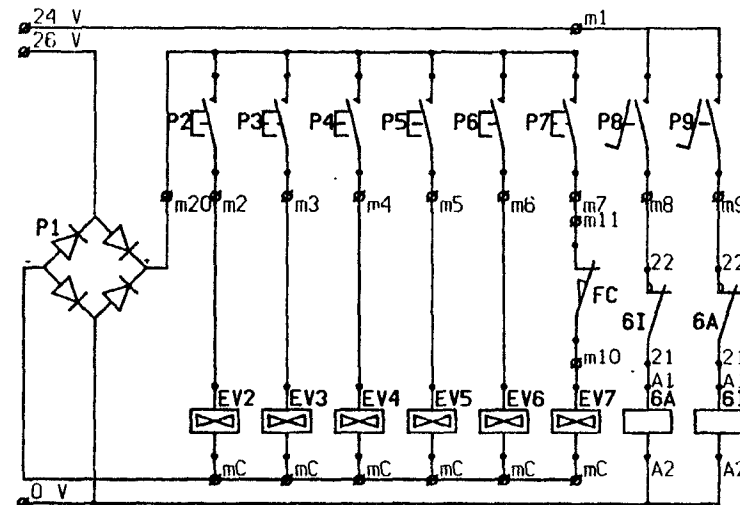
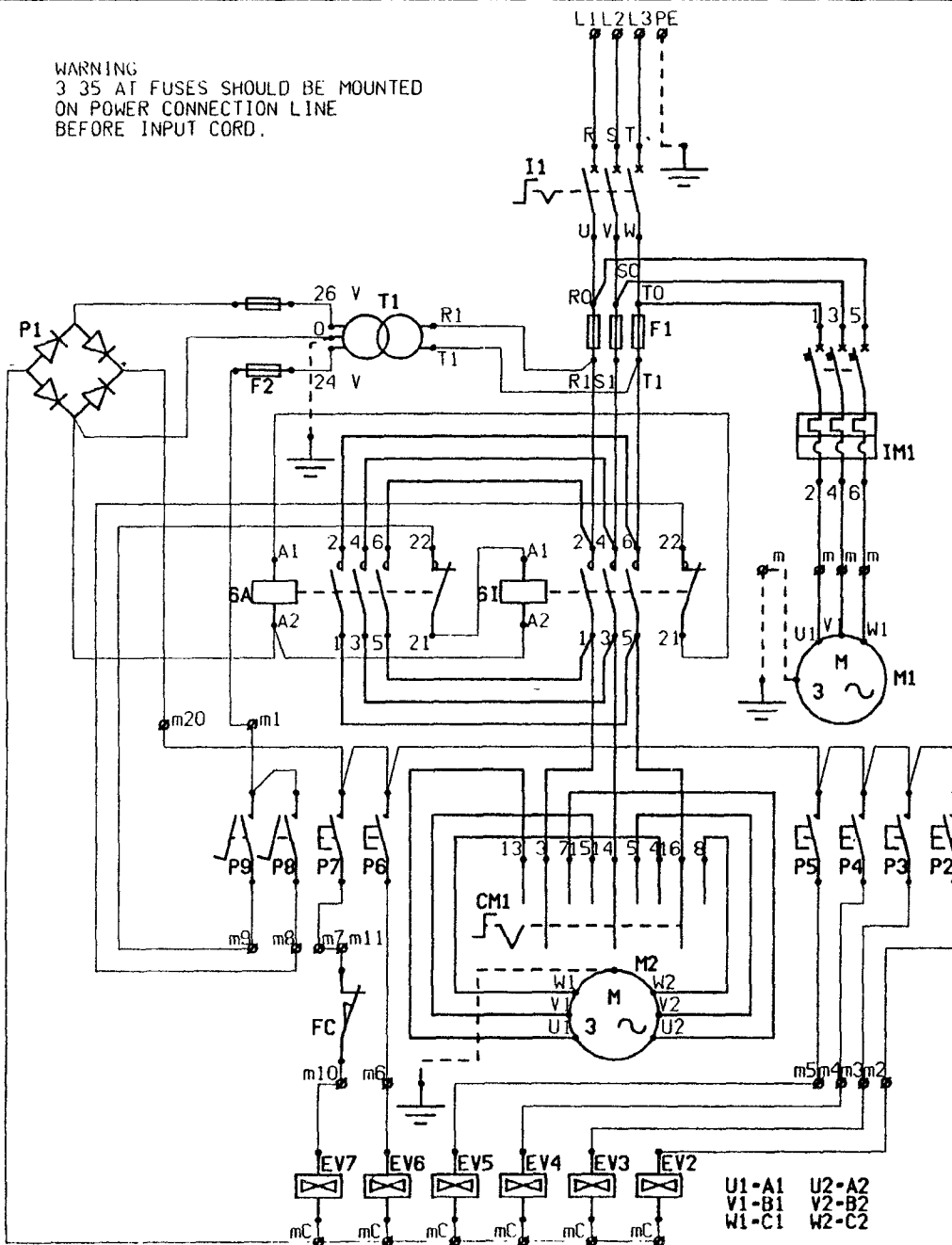

- CM1 polarity switch
- EV 2-7 electric valves
- FC position switch
- F1 main circuit fuses (25 A)
- F2 command circuit fuses (1,4 A)
- I1 main switch
- IM1 thermal and electromagnetic switch
- M1 pump motor
- M2 chuck motor
- mC 1-20 terminalblock
- P1 rectifier
- P 2-9 command switches
- T1 transformer
- 6A clockwise rotation contactor
- 6I counterclockwise rotation contactor

VERSION AT 24VDC

U1-A1 U2-A2
 V1-B1 V2-B2
 W1-C1 W2-C2

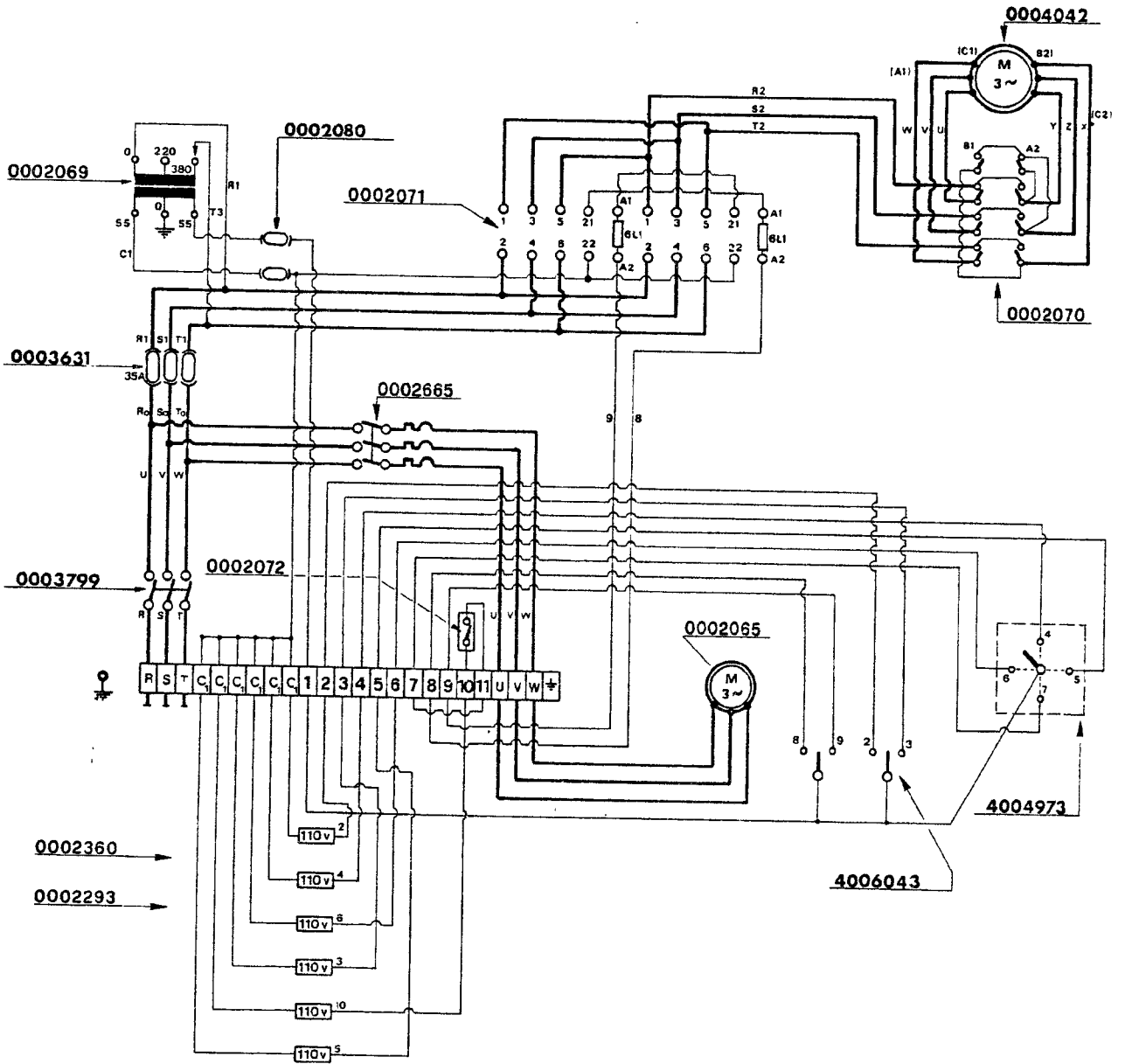

ACCU model 4440

Catalogo ricambi

Spare parts

Pieces detachées

Ersatzteile

Repuestos

* All'ordine specificare: tipo macchina e matricola codice e quantità del particolare.

* On order specify: type of machine and serial number item code and quantity.

* A la commande: bien préciser le type de la machine, le n de serie, la référence de pièce, la quantité.

* Bei Auftragserteilung anzugeben: Maschinentype, Seriennummer, Artikel-Code, Menge.

* En cada pedido hay que especificar : el tipo de máquina y su número de matrícula, el número de código de la pieza requerida y su cantidad.

120

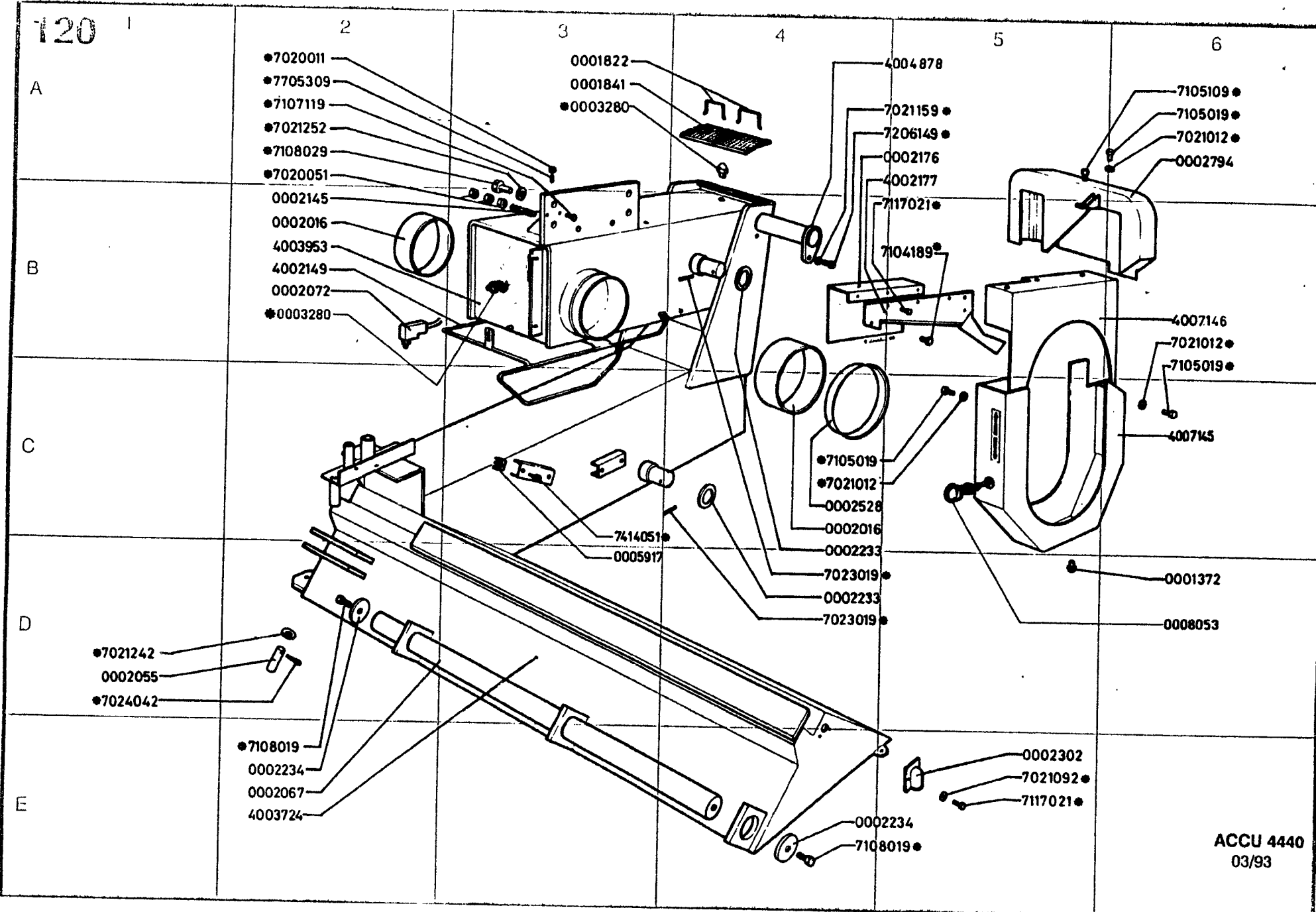

- 7020011
- 7705309
- 7107119
- 7021252
- 7108029
- 7020051

- 0001822
- 0001841
- 0003280

- 4004878
- 7021159
- 7206149
- 0002176
- 4002177
- 7117021

- 7105109 ●
- 7105019 ●
- 7021012 ●
- 0002794

- 0002145
- 0002016
- 4003953
- 4002149
- 0002072
- 0003280

- 7104189 ●

- 4007146
- 7021012 ●
- 7105019 ●

- 7105019
- 7021012

- 400745

- 7414051 ●
- 0005917

- 0002528
- 0002016
- 0002233
- 7023019 ●
- 0002233
- 7023019 ●

- 0001372

- 0008053

- 7021242
- 0002055
- 7024042

- 7108019
- 0002234
- 0002067
- 4003724

- 0002234
- 7108019 ●

- 0002302
- 7021092 ●
- 7117021 ●

ACCU 4440
03/93

121

2

3

4

5

6

A

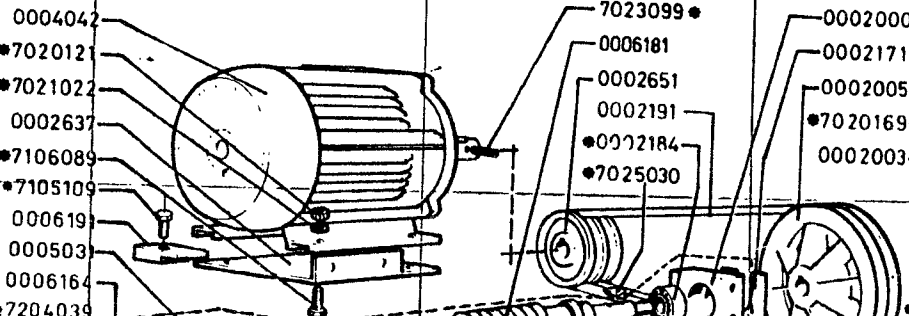

B

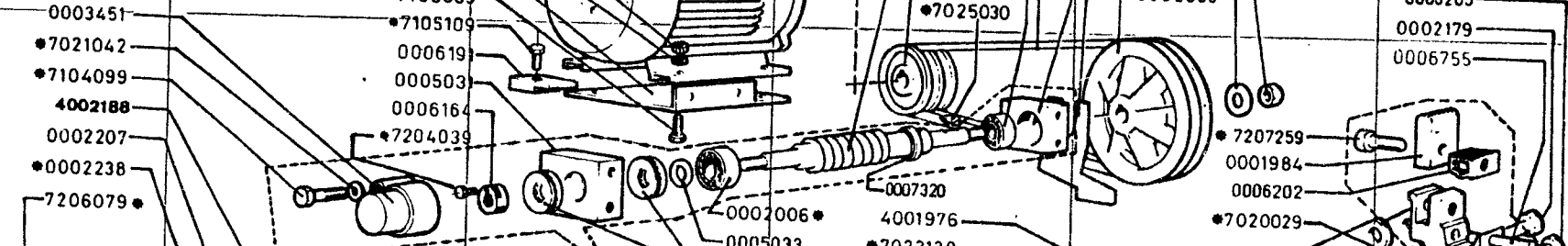

C

*Wisher
200 U 2238*

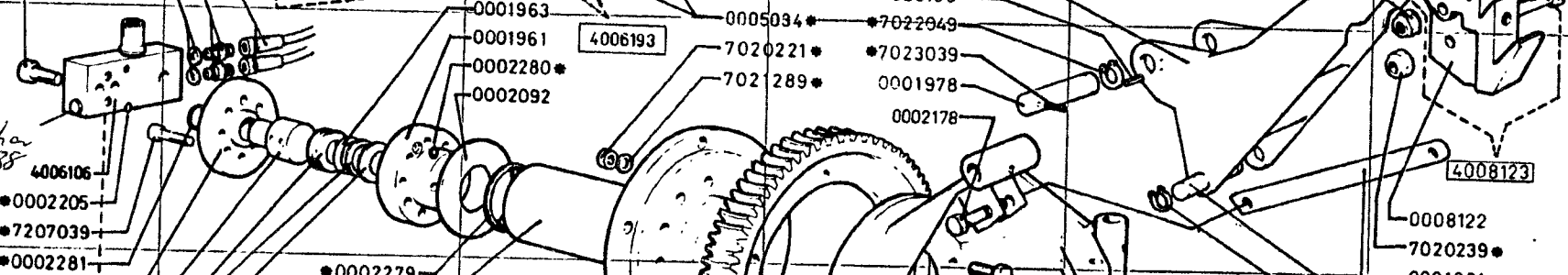

D

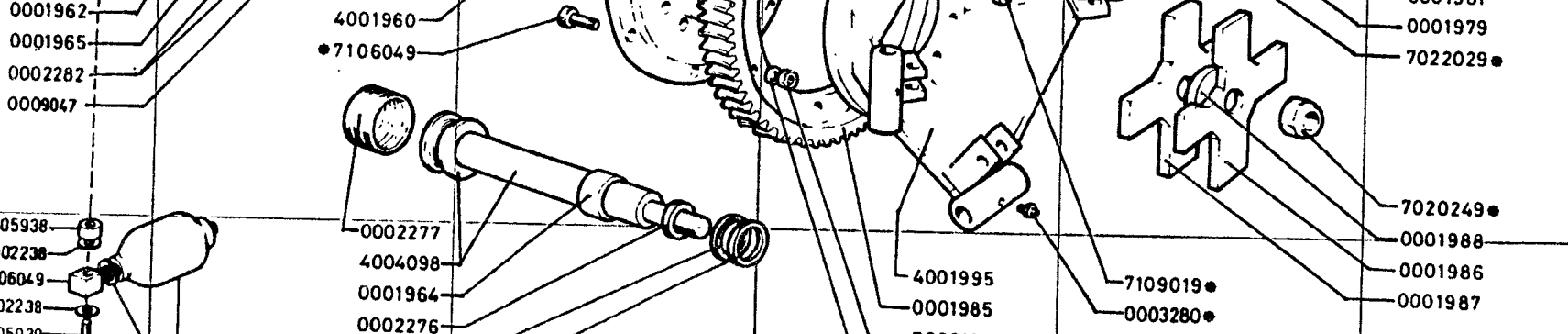

E

ACCU 4440
03/93

122 1

2

3

4

5

6

A

B

C

D

E

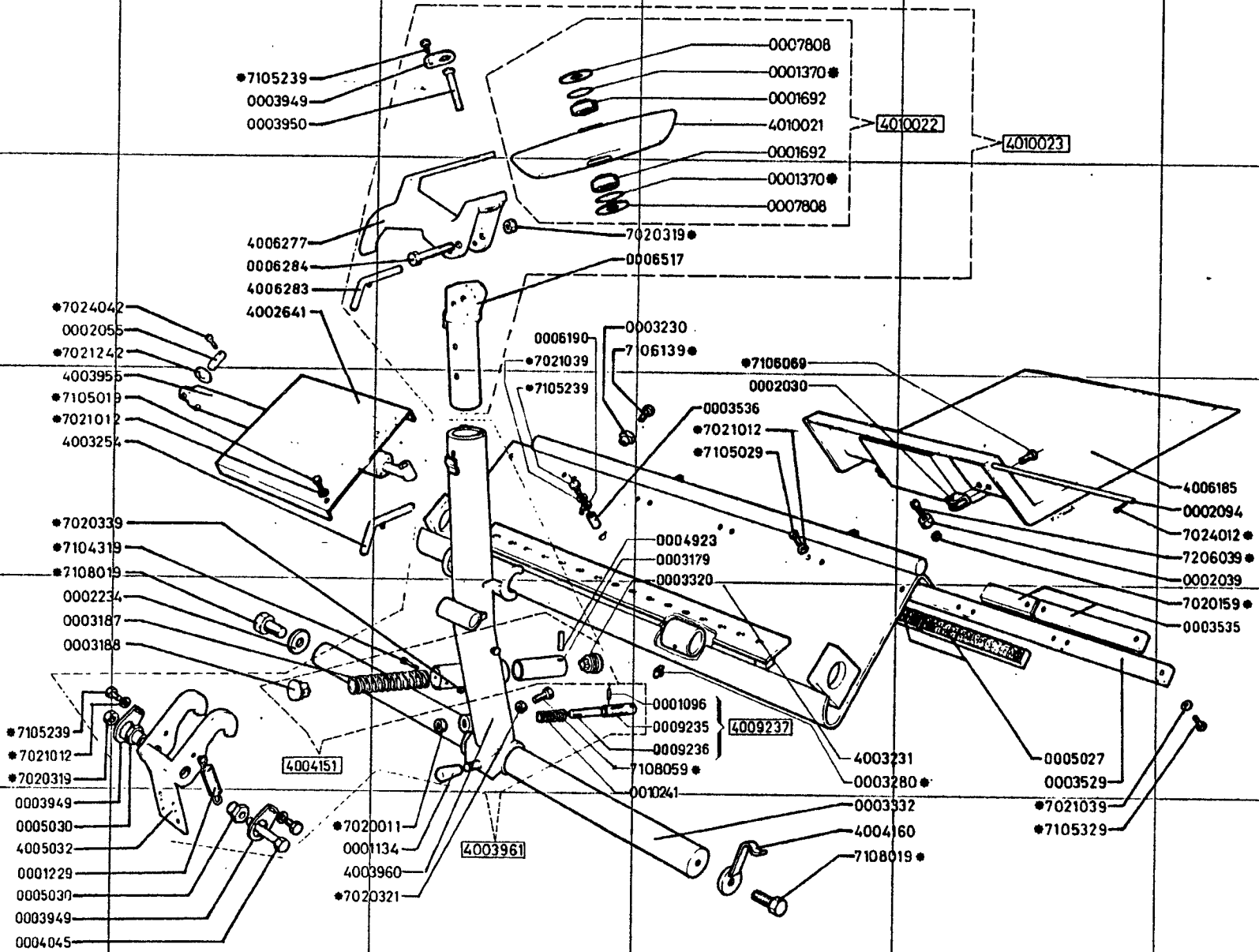

ACCU 4440
03/93

123

A

B

C

D

E

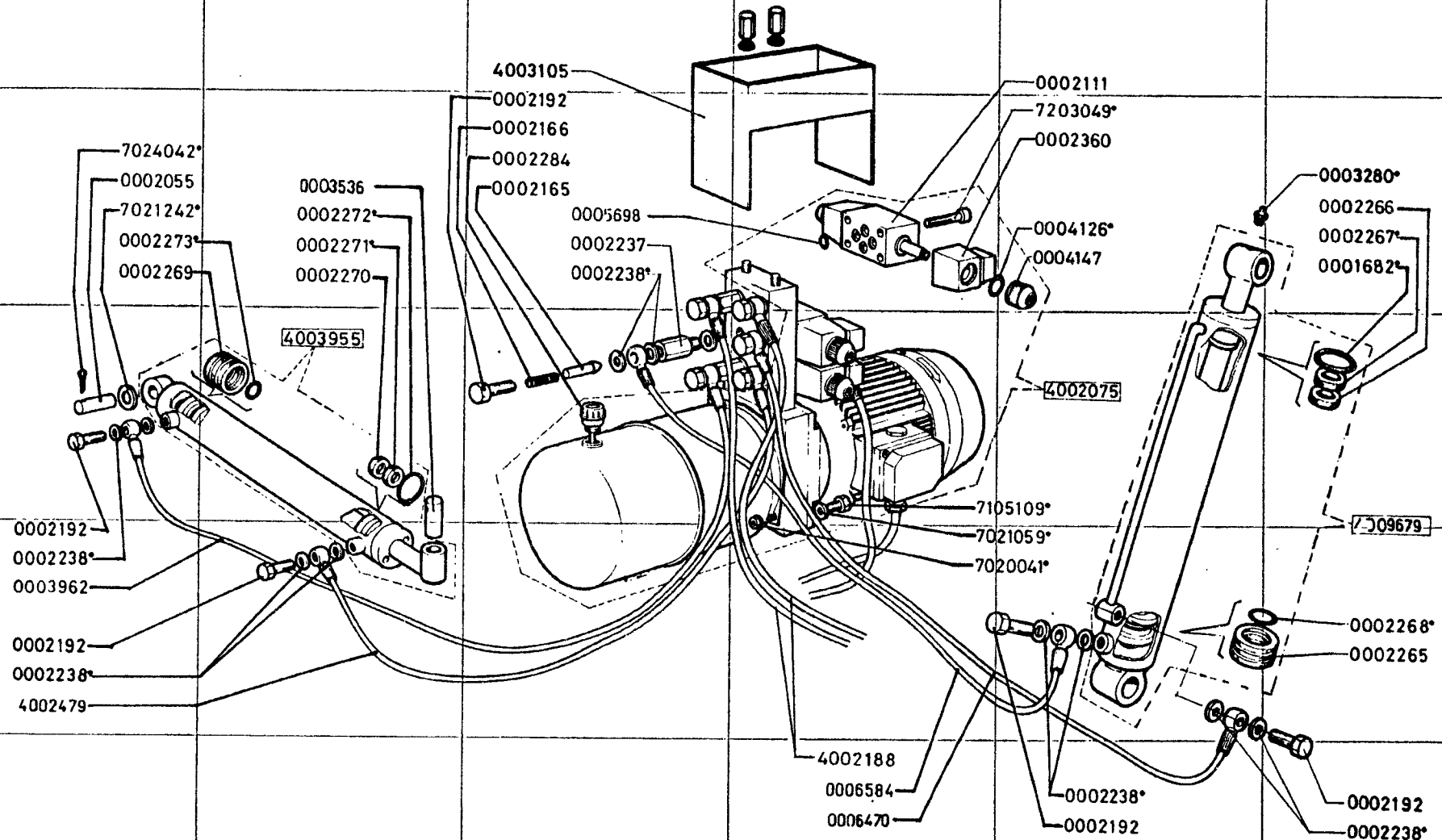

ACCU 4440
03/93

124

A

B

C

D

E

2

3

4

5

6

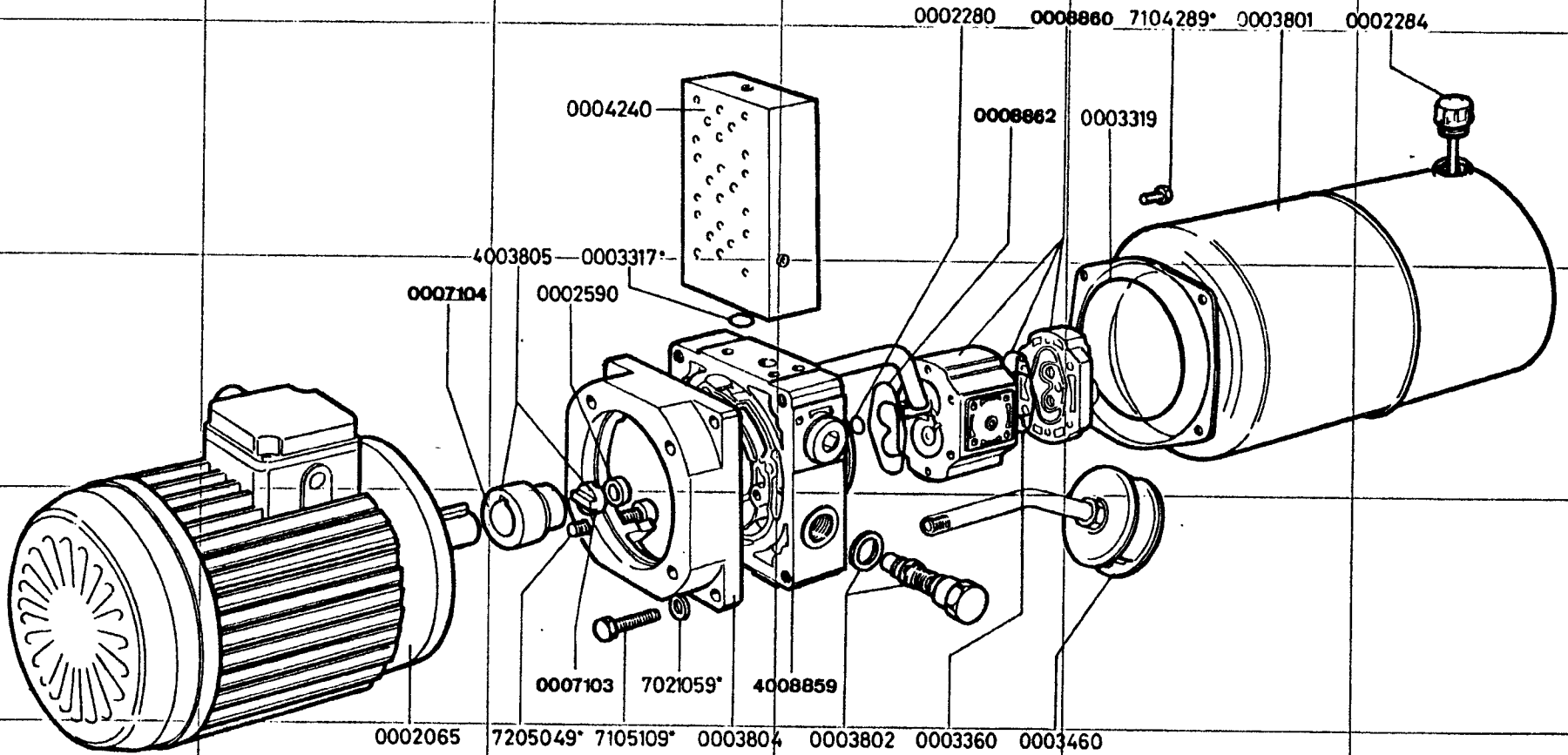

ACCU 4440
03/93

23

1 2 3 4 5 6 7 8 9

A

B

C

D

E





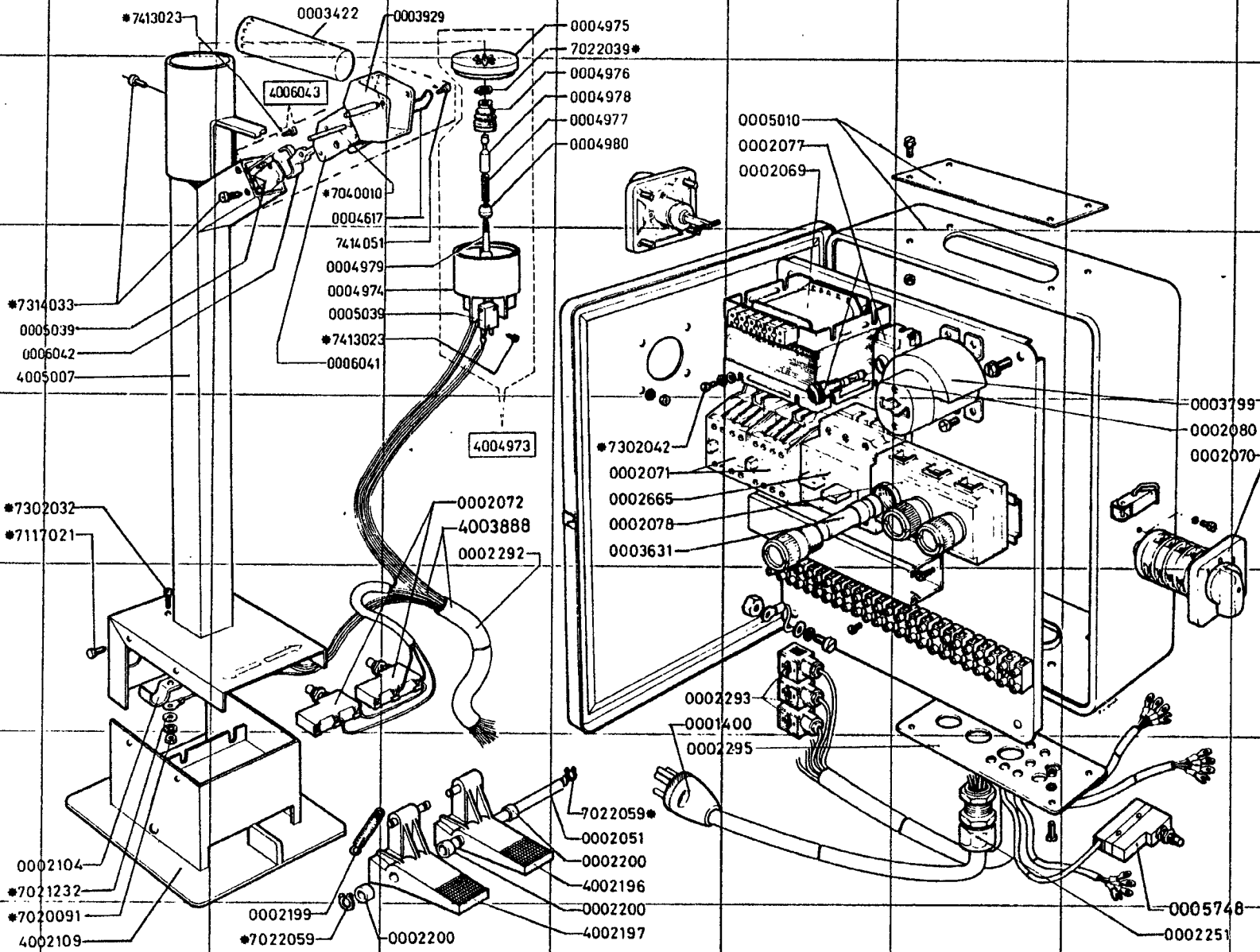















F

G



ACCU 4440
03/93

COMMERCIAL SPARE PARTS

	7117021 = 10E x 13 DIN 7976/B2		7203049 = 5x30 8G 7204039 = 6x16 8G 7206039 = 10 x 60 8G 7206079 = 10 x 35 8G 7206149 = 10 x 25 8G 7207039 = 12 x 50 8G 7205049 = 8 x 25 8G 7207259 = 12x45 8G		0002267 = D35 WRM 137169 0002271 = D25
	7413023 = 4P x 16 DIN 7981 7314033 = 6P x 9,5 DIN 7981 7414051 = 6P x 6,5 DIN 7981		7705309 = 8 x 30 8G		7025030 = 8 x 11
	7020011 = M8 6S 7020041 = M6 6S 7020051 = M12 6S 7020091 = M4 6S 7020121 = M10 6S 7020221 = M18 6S 7020321 = M14 6S		7302032 = 4 x 16 6S 7302042 = 4 x 10 6S		7021039 = D8 DIN 6798/A 7021159 = D10 DIN 6798/A
	7020029 = M14 5S I 7020159 = M10 6S I 7020169 = M8 16 x 1,5 5S I 7020239 = M12 5S I 7020249 = M8 27 x 2 5S I 7020319 = M20 5S I 7020339 = M6 5S I		0001566 = D12,8x9,25x1,78 OR 2037 GACO 0001682 = D75,32x68,26x3,53 OR 171 GACO 0002205 = D8,84x5,28x1,78 OR 2021 GACO 0002268 = D29,05x23,81x2,62 OR 132 GACO 0002272 = D56,27x49,21x3,53 OR 153 GACO 0002273 = D21,12x15,88x2,62 OR 121 GACO 0002279 = D92,38x85,32x3,53 OR 4337 GACO 0002280 = D11,22x7,66x1,78 OR 2031 GACO 0002281 = D46,75x39,69x3,53 OR 144 GACO 0003317 = D14,43x9,19x2,62 OR 3037 GACO 0004126 = D25,7x18,64x3,53 OR 4075 GACO		0002238 = 1/4
	7021012 = D8 7021022 = D10 7021042 = D6 7021232 = D4 7021242 = D20 7021252 = D14		0002006 = 25 x 52 x 15 CFC 6205-2Z 0002184 = 25 x 52 x 15 CFC 6205-2RS		7023019 = 6 x 50 DIN 1481 7023039 = 6 x 40 DIN 1481 7023099 = 4 x 40 DIN 1481 7023139 = 6 x 20 DIN 1481
	7104099 = 6x35 8G 7104189 = 6x12 8G 7104319 = 6x55 8G 7105029 = 8 x 25 8G 7105019 = 8 x 16 8G 7105109 = 8 x 20 8G 7105239 = 8 x 12 8G 7105329 = 8 x 40 8G 7106049 = 10 x 40 8G 7106069 = 10x20 8G 7106089 = 10x35 8G 7106139 = 10x50 8G 7107119 = 12 x 16 8G 7108019 = 14 x 20 8G 7108029 = 14 x 35 8G 7108059 = 14 x 25 8G 7109019 = 16 x 80 8G		0005034 = SKF 51305		7022029 = D16 7022049 = D25 7022059 = D12 7022039 = D10
					0003280 = M8
					7024042 = 4 x 40 7024012 = 3 x 25