

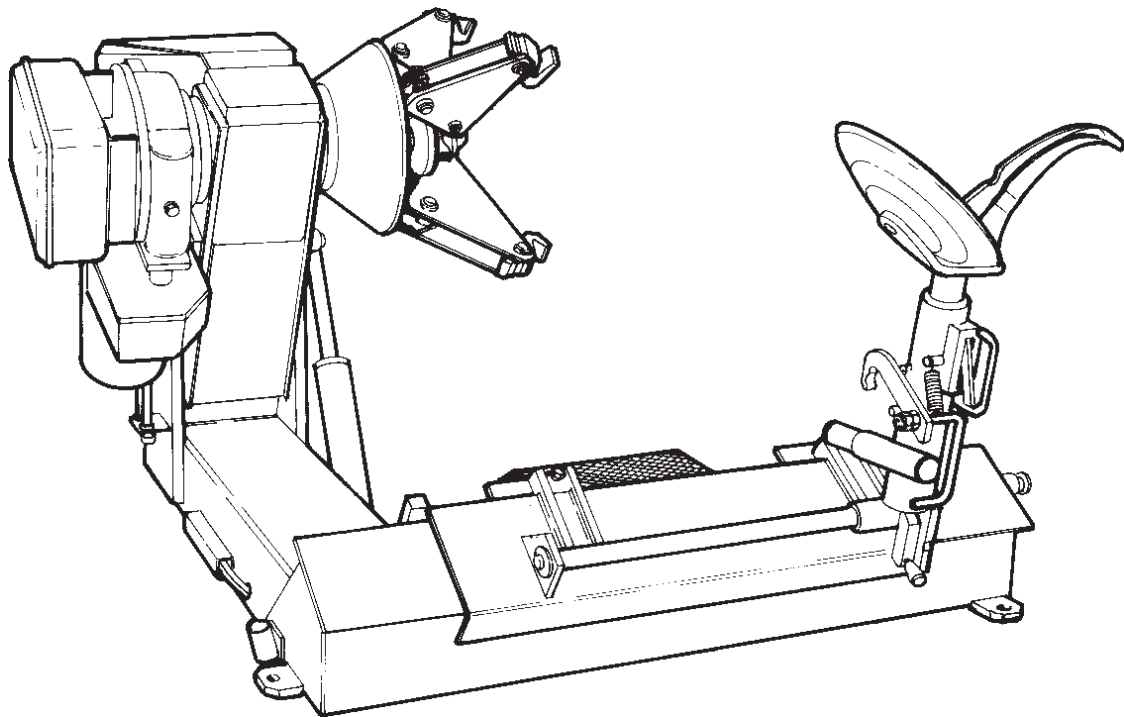

OPERATOR'S MANUAL - SPARE PARTS EXPLODED VIEWS



Electric-Hydraulic Tire Changer
for Truck Wheels

ACCU 4260

Rev.:B

DISCLAIMER OF WARRANTIES AND LIMITATIONS OF LIABILITIES

While the authors have taken care in the preparation of this manual, nothing contained herein:

- modifies or alters in any way the standard terms and conditions of the purchase, lease or rental agreement under the terms of which the equipment to which this manual relates was acquired,
- increases in any way the liability to the customer or to third parties.

TO THE READER

While every effort has been made to ensure that the information contained in this manual is correct, complete and up-to date, the right to change any part of this document at any time without prior notice is reserved.

Before installing, maintaining or operating this unit, please read this manual carefully, paying extra attention to the safety warnings and precautions.

All Information in this manual has been supplied by the producer of the equipment to:



Accu Industries, Inc.
P.O. BOX 15540 / RICHMOND, VA 23227
11126 AIR PARK ROAD / ASHLAND, VA 23005
804-798-8922 FAX 804-798-6742
www.accu-turn.com

1.0 Introduction

Congratulations on purchasing the **ACCU model 4260** tire changer!

The **ACCU model 4260** is an electric-hydraulic machine designed to mount and demount tubeless and tube-type truck tires.

Read this manual thoroughly before installing and operating the machine.

If any of the directions in this manual are not perfectly clear you should contact your immediate supervisor or your authorized ACCU distributor for clarification.

1. 8 position switch
2. Chuck switch
3. Toolholder arm
4. ON/OFF switch
5. Pedal toolholder release
6. Toolholder Carriage
7. Ramp
8. Jaws
9. Self-centering chuck
10. Chuck arm
11. Chuck rotation control pedal
12. Mount/demounting tool
13. Electric cabinet

1.1 Nomenclature

Before installing and using the **ACCU model 4260** you should become familiar with the proper nomenclature of it's components (Fig.1).

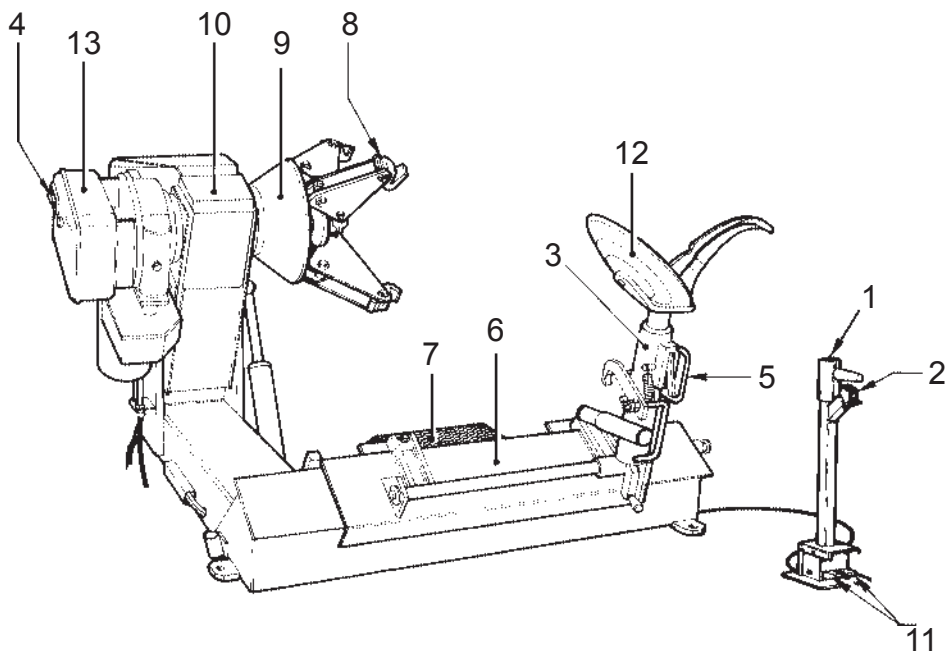

Fig.1

1.2 Specifications

Electric/hydraulic tire changer for tubeless and tube-type truck tires.

Weight	1210 lbs (kg 550)
Hydraulic system motor	3phase 1.5 kW (2 HP)
Chuck rotation motor	3phase 1.5 kW (2 HP)
Chuck capacity	14" - 26"
Max. tire diameter	59" (mm 1500)
Max. tire width	27" 1/2 (mm 700)
Max. torque	ftxlbs 1100 (Nm 1500)
Clamping power	lbs 17200 (76.5 kN)
Chuck rotation speed	7 rpm

1.3 Dimensions of the Machine

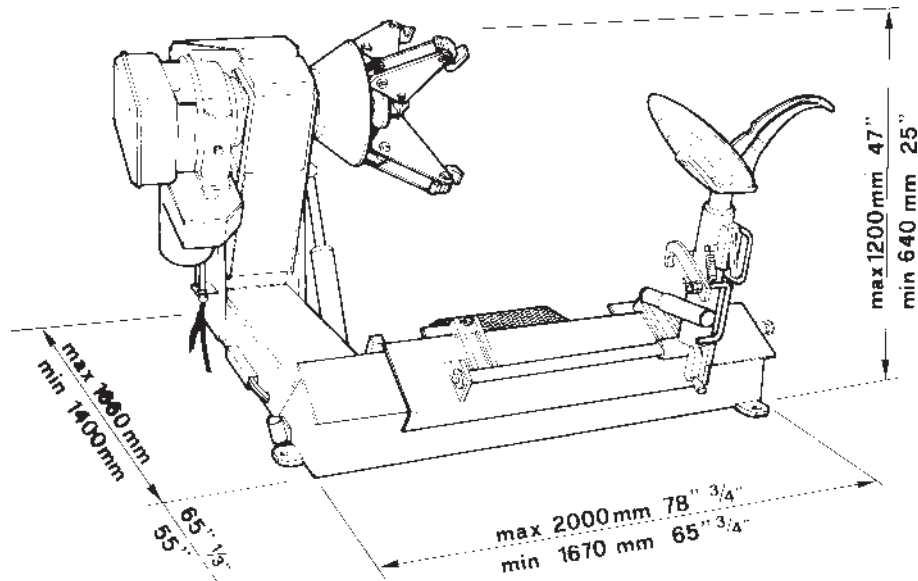

Fig.2

1.4 Standard Accessories

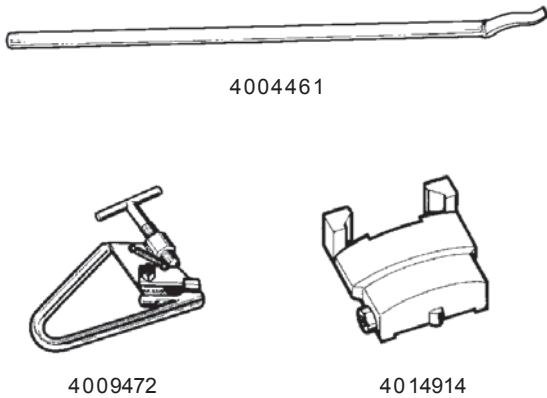

Fig. 3

- #4004461 Long tire tool
- #4009472 Mounting clamp
- #4014914 Protectors for alloy rims

393 - 295 - 558

1.6 General Precautions

A. BEFORE SERVICING ANY TRUCK TIRES, WHEELS OR RIMS, ALL PERSONNEL SHOULD RECEIVE THOROUGH TRAINING FOR THE PROPER SERVICING OF TRUCK TIRES, WHEELS AND RIMS. CONSULT WITH YOUR LOCAL CITY, COUNTRY STATE, AND COUNTRY SAFETY AND HEALTH ADMISTRATIONS TO RECEIVE CLARIFICATION OF ANY PUBLICATIONS AVAILABLE GOVERNING THIS SERIOUS MATTER (IN THE UNITED STATES OF AMERICA CONSULT O.S.H.A. REGULATION29 CFR 1910.177).

B. DURING THE INSTALLATION, USE AND MAINTENANCE OF THE MACHINE IT IS MANDATORY TO COMPLY WITH ALL LAWS AND REGULATIONS FOR ACCIDENT PREVENTION.

C. BEFORE ANY MAINTENANCE OR REPAIRS ARE ACCOMPLISHED THE MACHINE MUST BE DISCONNECTED FROM THE ELECTRIC SUPPLY.

D. NEVER WEAR TIES, CHAINS OR OTHER LOOSE ARTICLES WHEN USING, MAINTAINING OR REPAIRING THE MACHINE. LONG HAIR IS ALSO DANGEROUS AND SHOULD BE KEPT UNDER A HAT OR SIMILAR. THE USER MUST WEAR PROPER SAFETY ATTIRE, I.E. GLOVES, SAFETY SHOES AND GLASSES.

E. NOBODY SHOULD BE ALLOWED TO STAND NEXT TO THE WHEEL, WHEN MOUNTING/ DEMOUNTING A TIRE OR CLAMPING A WHEEL.

F. PROPERLY ATTACH THE MACHINE TO THE FLOOR.

1.5 Optional Accessories

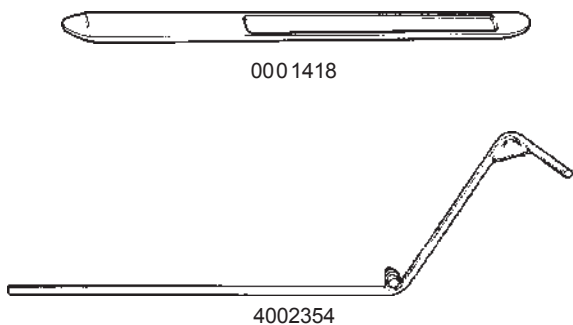

Fig. 4

- #4001418 Short tire tool
- #4002354 Bead pushing lever

294 - 557

2.0 Installation

The machine must be installed in a covered area, preferably completely closed.

The floor must be in good condition and must have the structural integrity necessary to support the weight of the machine and of the assembly being serviced.

Ensure enough space to operate the machine correctly (chapter 1.3).

Before lifting the machine be sure that the chuck is closed, the chuck arm lowered, and the toolholder carriage is in all the way.

If the machine is crated, remove the screws that hold it to the pallet.

Lift the machine by the chuck arm only (Fig. 5).

This should be accomplished by wrapping a chain or strap of adequate strength around the chuck arm so it can be hooked by crane or forklift.

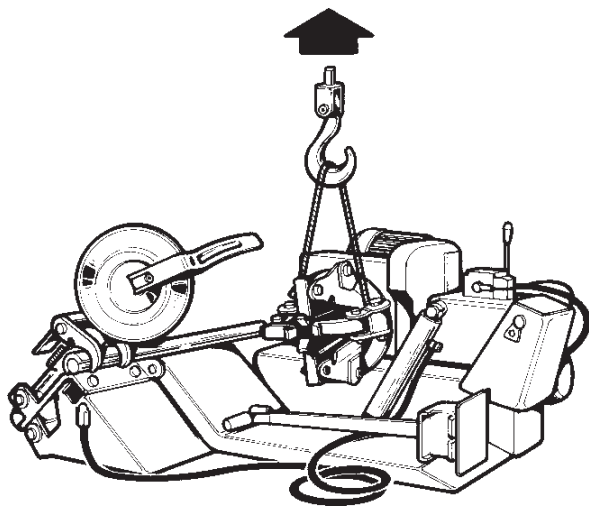

Fig. 5

832

WARNING!

**DO NOT SWING THE MACHINE WHEN LIFTED.
DO NOT CUT THE REMOTE UNIT CORD WHEN LOWERING THE MACHINE TO THE GROUND.**

2.1 Electric Installation

WARNING!

THE ELECTRIC HOOK-UP MUST BE MADE BY A LICENSED ELECTRICIAN.

GROUND IS YELLOW WITH GREEN STRIPE.

USE AN APPROVED PLUG.

Ensure that the electric specifications of the work area are the same as the machine.

Once the machine is hooked-up, turn the machine on using the ON/OFF switch.

Ensure that the rotation direction of the pump is the same as indicated by the arrow on the motor cover.

If not, reverse any two-phase cables on the plug (i.e. reverse the brown and the blue cable).

WARNING!

IF THE PUMP TURNS IN THE WRONG DIRECTION, THE HYDRAULIC CYLINDERS DO NOT MOVE SMOOTHLY AND THE PUMP MAY BE SERIOUSLY DAMAGED.

3.0 Controls

Before operating the machine it is necessary to become familiar with the controls located on the remote control unit and on the electric cabinet.

A. To turn the machine on, rotate the ON/OFF switch (#4 Fig.1) to position "1": the pump motor starts turning and remains in operation until which time the machine is turned off. The power required is minimum when the hydraulic cylinders are not in use.

NOTE:

IT IS SUGGESTED TO TURN THE MACHINE OFF AFTER EVERY MOUNTING OR DEMOUNTING OPERATION, IF THE TIME BEFORE THE NEXT OPERATION IS LONGER THAN 5 MINUTES.

B. Press chuck rotation pedal (#11 Fig.1) identified by a black arrow: the chuck turns clockwise. Press the opposite pedal to turn the chuck counter clockwise.

C. Operate the 8-position switch as shown in Fig. 6: the chuck arm moves up. Operate the switch in the opposite way to lower the chuck arm.

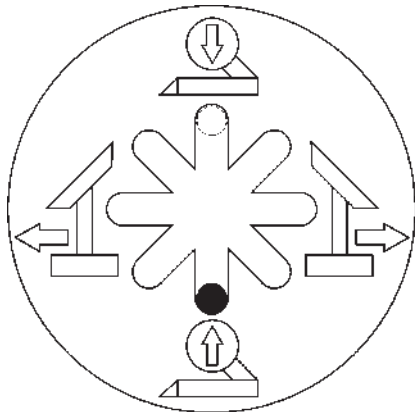

Fig. 6

1083

D. Move the 8-position switch to the right (Fig. 7) to move the tool holder carriage to the outside. Operate the switch to the left to move the carriage towards the inside.

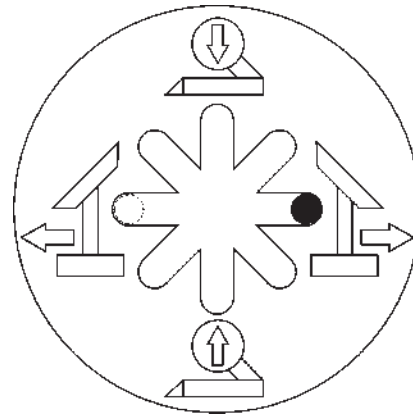

Fig. 7

1084

E. Move the switch to a diagonal positions, to operate the two movements simultaneously. This operation allow for substantial time saved but requires a little practice.

NOTE:

IF ONE OF TWO HYDRAULIC MOVEMENTS ACTIVATED GETS TO THE END OF THE STROKE THE SPEED OF THE OTHER MOVEMENT WILL CONSIDERABLY DIMINUIH.

STOP THE COMBINED CONTROL AND ACTIVATE ONLY ONE MOVEMENT TO OBTAIN A NORMAL SPEED.

F. To lift the tool holder arm, depress the pedal (#1 Fig.8) and hold handle (#2 Fig.8).

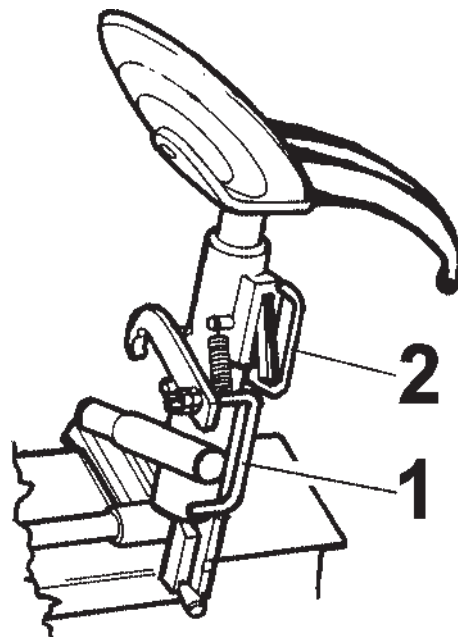

Fig. 8

608

The arm is balanced by a spring-loaded mechanism and the effort required is minimum.

When locking the arm into working position be sure to use enough force to ensure a proper lock. The heavy metal construction can easily absorb the force.

WARNING!

IF THE TOOLHOLDER ARM IS NOT CORRECTLY LOCKED IN THE WORKING POSITION SERIOUS INJURY MAY RESULT TO THE OPERATOR AND TO THE MACHINE.

G. To turn the tool depress the handle (#1 Fig.9). Release the handle to lock the tool.

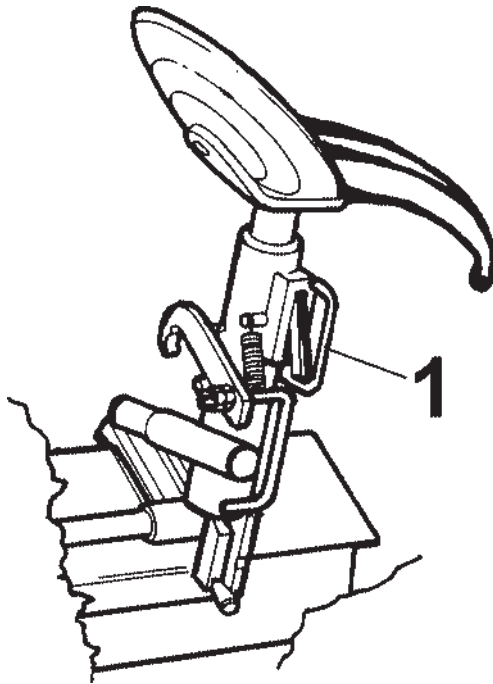

Fig.9

609

WARNING!

BE SURE THAT THE LOCK PIN IS PROPERLY FITTED.

H. To open and close the chuck, operate the chuck switch (Fig.10).

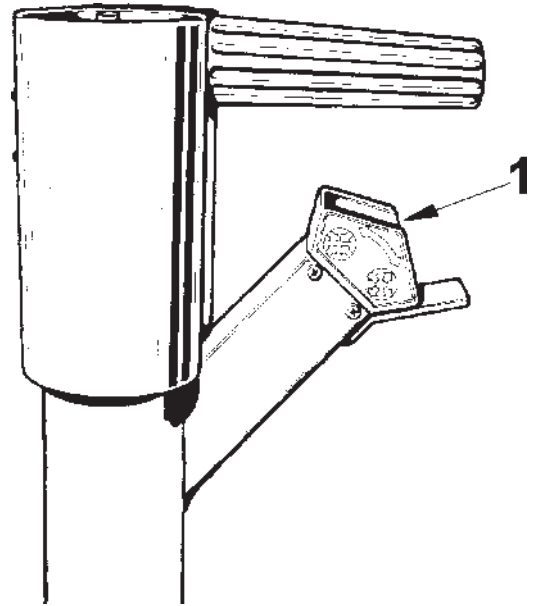

Fig. 10

577

WARNING!

BEFORE LIFTING THE TOOL HOLDER ARM BE SURE THAT NOBODY IS STANDING IN THE OPERATION AREA.

4.0 Rim Clamping

Move the footboard (#7 Fig.1) and the tool holder carriage (#6 Fig.1) all the way out. Put the wheel in vertically and roll it on the footboard. Be sure to use alloy adapters when applicable.

ATTENTION!

THE DROP CENTER OF THE RIM (WHEN IT EXISTS) MUST BE KEPT TOWARDS THE OUTSIDE OF THE MACHINE (Fig.11).

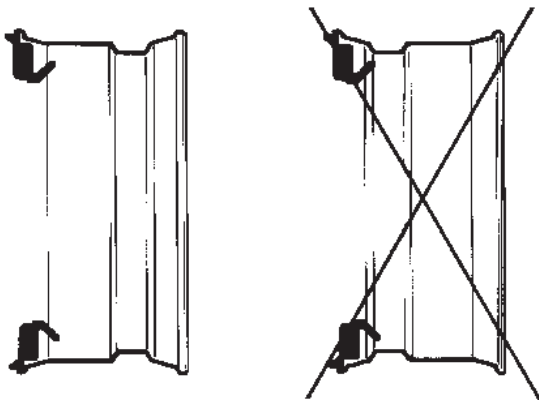

(Fig.11)

402

WARNING!

IF THE WHEEL IS VERY HEAVY BE SURE TO USE A SUITABLE EXTERNAL LIFTING DEVICE (I.E. FORK LIFT, CRANE ETC.).

Close the jaws of the chuck (#8 Fig.1) and move the chuck approximately to the center of the rim. Move the footboard toward the chuck and move the chuck up-down while opening the chuck arms until the rim is clamped properly (Fig.12).

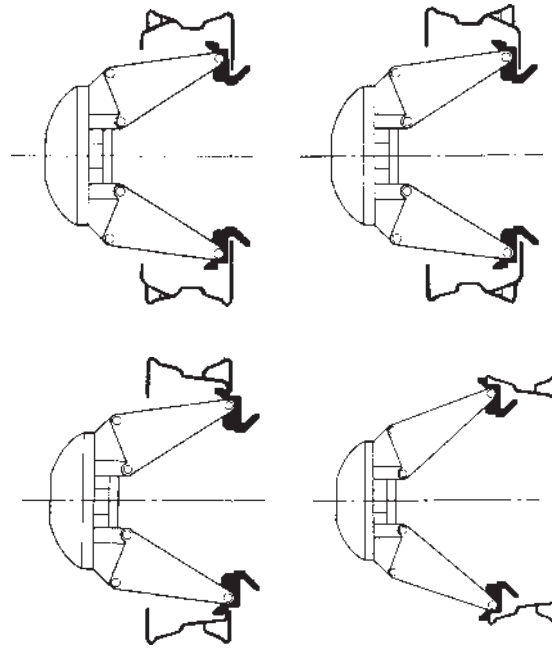

(Fig.12)

600 - 601 - 602 - 603

5.0 Demounting Tubeless Truck Tires (Up to 13" Wide)

The tubeless truck tires are mounted on drop-center rims with a conical base. It is possible to demount these tires simply by pressure, with a proper lubrication (Fig.13).

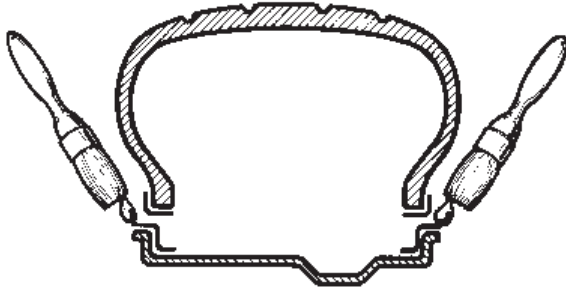

Fig. 13

1. Position the bead breaker disc as shown in Fig.14.

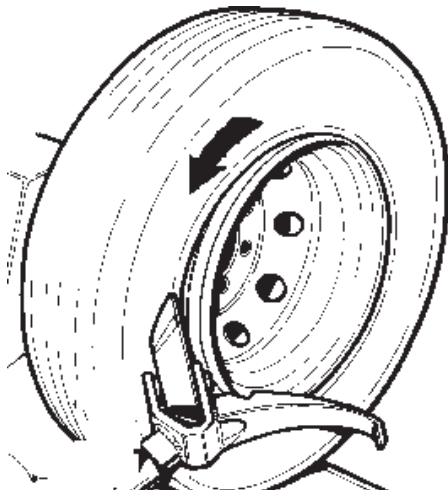

Fig. 14

2. Lift or lower the chuck so that the bead breaker disc remains close to the rim edge. Turn the chuck counter-clockwise and at the same time move the tool holder carriage step-by-step towards the inside to break the bead. Continue to turn the chuck and lubricate the bead and the rim liberally with an approved lubricant.

WARNING!

USE ONLY SPECIFIC LUBRICANTS FOR TIRES AND WHEELS.

APPROVED LUBRICANTS DO NOT CONTAIN WATER, PETROLEUM PRODUCTS/ HYDROCARBONS, OR SILICONE.

3. Lift the tool holder arm to idle position. Rotate the tool 180 degrees until locked.

4. Move the tool holder arm all the way in. Lower the tool holder arm and lock it down. Move the tool holder carriage until the disc is in contact with the inner bead.

5. Break the inner bead as described in #2.

6. Continue to rotate the chuck while moving the tool holder carriage towards the outside until both beads are demounted from the rim (Fig.15).

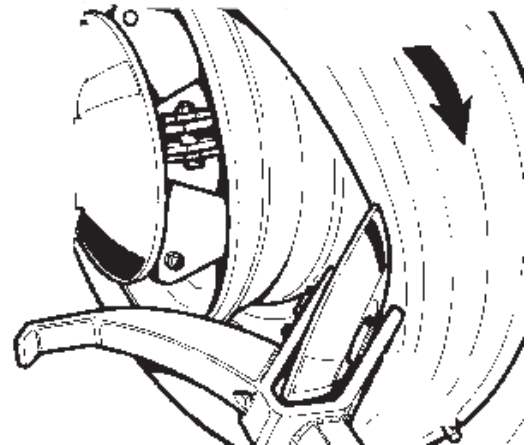
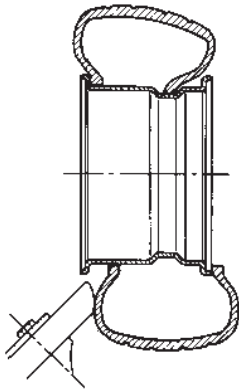

Fig.15

WARNING!

ENSURE THAT THE OUTER BEAD SLIDES INTO THE DROP CENTER OPPOSITE TO THE TOOL, OTHERWISE THE DEMOUNTING OPERATION IS IMPOSSIBLE.



7. Move to the front of the tire and hold it with both hands in the last part of demounting operation to prevent the tire from falling or rolling away out of control (Fig.16).

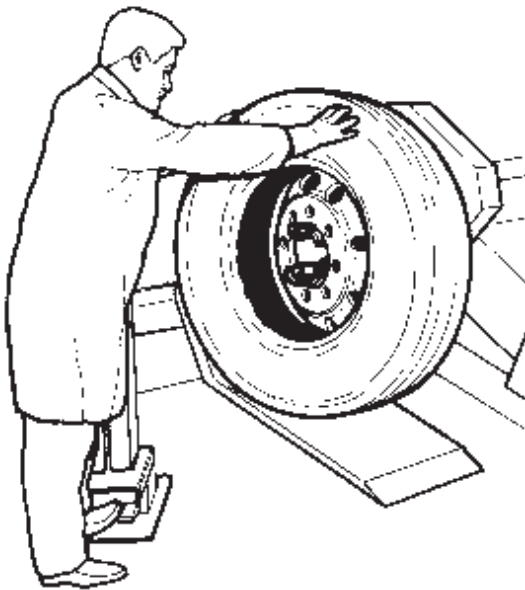

Fig.16

5.1 Mounting Tubeless Truck Tires (Up to 13" Wide)

1. Liberally lubricate the entire inner surface of the rim and the tire beads. Attach the mounting clamp #4009472 (#1 Fig.17) to the outer rim flange with the valve at 11 o'clock and the clamp at 12 o'clock.

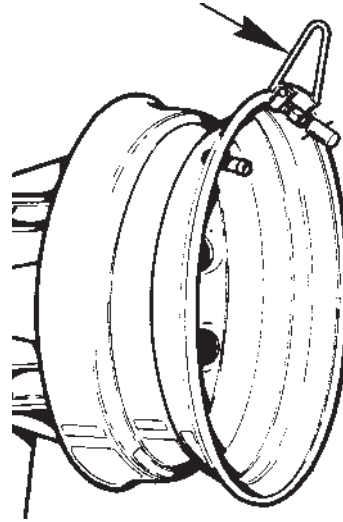

Fig.17

If the rim is made of a light-alloy, the rim edge shape will not allow you to attach a mounting clamp. In such a case do not use a clamp.

2. Move the chuck arm all the way down. Roll the tire on the footboard and hang it onto the mounting clamp (Fig.18).

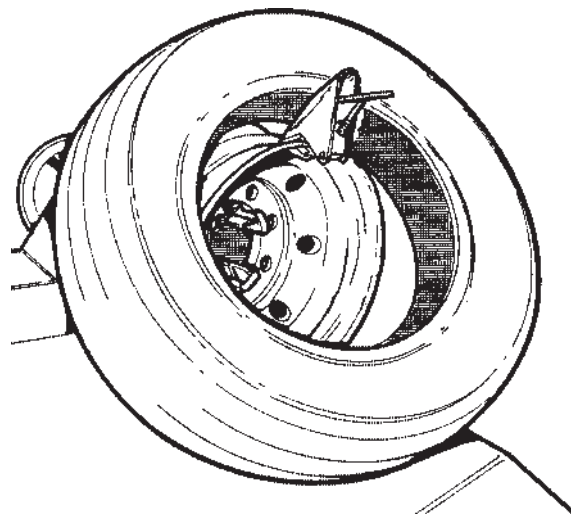

Fig.18

3. Lift the chuck arm and position the mounting hook approximately 1/2" (1.5 cm) to the inside of the rim edge and approximately 1/2" (1.5 cm) away from the rim edge. The mounting clamp is at 11 approximately o'clock.

WARNING!

NEVER USE HAND PRESSURE TO HOLD THE TIRE ONTO THE RIM.

4. Turn the chuck *clockwise* until the tire is completely mounted (Fig.20).

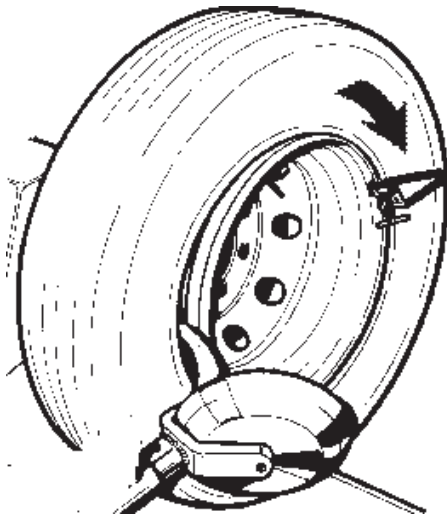

Fig.20

Ensure that the outer bead descends into the drop centre when the clamp is opposite to the tool.

WARNING!

STOP THE CHUCK BEFORE ONE COMPLETE TURN IS MADE TO AVOID SERIOUS DAMAGE TO THE MOUNTING CLAMP AND TO THE RIM.

WARNING!

RECOMMENDED PROCEDURES REQUIRE THAT TRUCK TIRES BE INFLATED TO NO MORE THAN 3-5 PSI FOR BEAD SEATING PURPOSES, OF MULTI-PIECE AND SINGLE PIECE ASSEMBLY RESPECTIVELY. FOR CONTINUED INFLATION THE ASSEMBLY MUST BE PLACED IN AN APPROVED INFLATION RESTRAINT DEVICE (IN THE UNITED STATES OF AMERICA CONSULT O.S.H.A. REGULATIONS CONCERNING THE PROPER SERVICING OF TRUCK WHEELS AND RIMS).

5.2 Demounting Duplex and Supersingle Tubeless Truck Tires (Over 13" Wide)

1. Break bead of the tire is described in chapter 5.0.1 & 5.0.5

2. For this type of tires it is not possible to demount both beads at the same time as described in chapter 5.0.6.

Engage the hook of the tool between the bead and the rim.

3. Lift the chuck arm enough to clear the hook 1"-1 1/2 (2-3 cm) from the rim flange. Move the tool towards the outside. This will allow you order to place the long bar in between the bead and the rim flange for necessary prying (Fig.22).

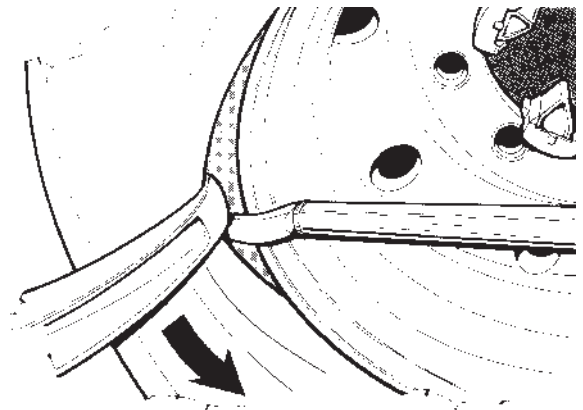

(Fig.22)

4. Rotate the chuck counter clockwise until the outer bead is completely demounted.

5. Demount the inner bead with the bead breaker disc, as described in chapter 5.0.6. (Fig.24).

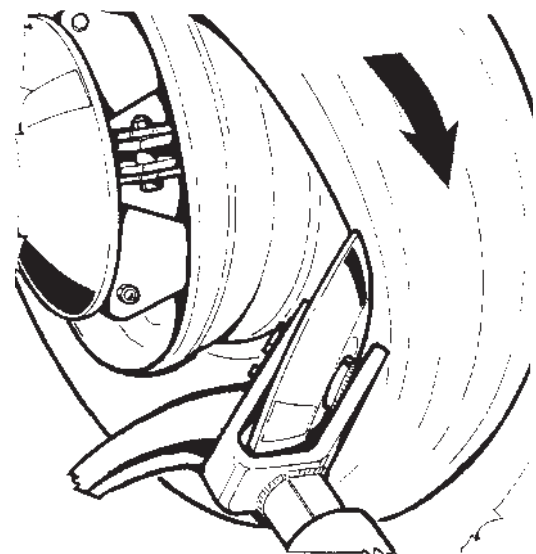

Fig.24

5.3 Mounting Duplex and Supersingle Tubeless Truck Tires (Over 13" Wide)

1. Hang the inner bead of the tire on the mounting clamp (Fig.25).

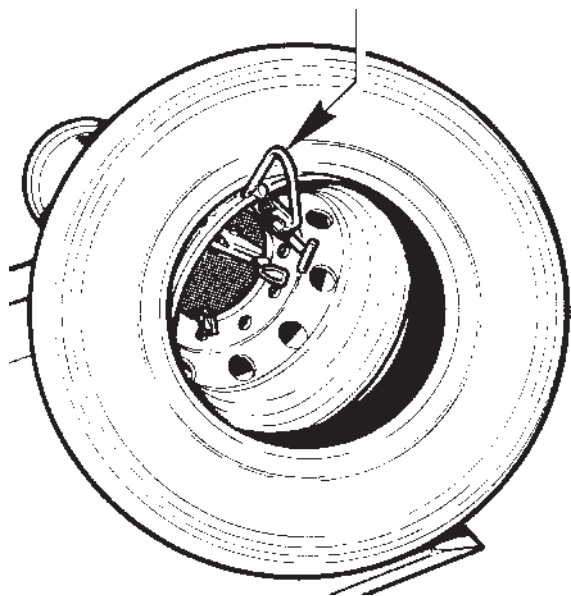

Fig.25

415

2. Position the mounting hook about 3/4" (1.5 cm) to the inside of the rim edge and 1/2" (1 cm) away radially. Rotate the chuck clockwise. Normally less than 1/4 of a revolution is sufficient to mount the first bead (Fig.26).

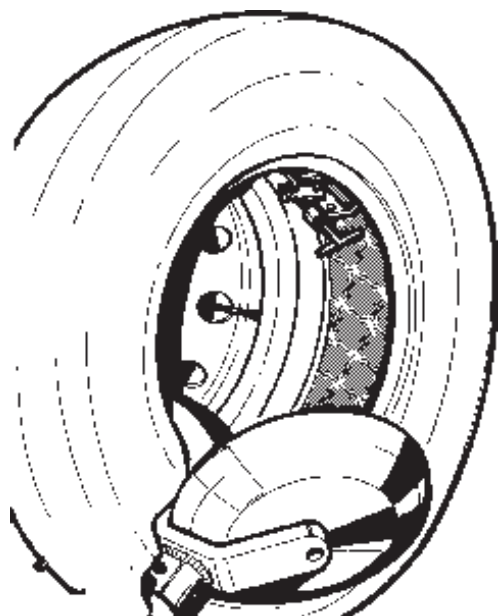

Fig.26

841

3. Reattach the mounting clamp to the rim flange with the valve after the mounting clamp, following the rotation direction (Fig.27).

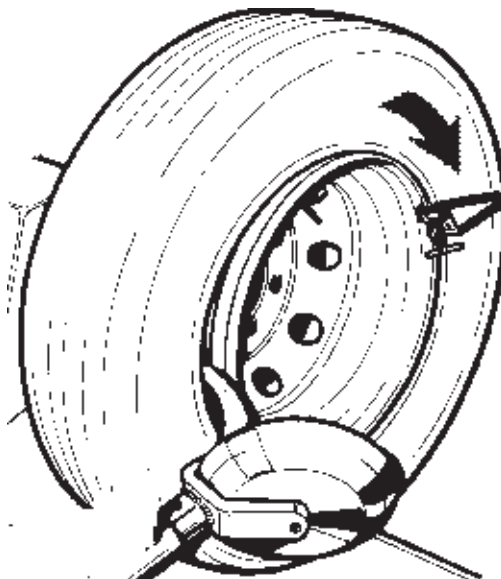

Fig.27

837

4. Rotate the chuck clockwise until the tire is completely mounted. Ensure that outer bead descends into the drop centre when the clamp is opposite to the tool.

WARNING!

NEVER USE HAND PRESSURE TO HOLD THE TIRE INTO THE RIM.

WARNING!

STOP THE CHUCK BEFORE ONE COMPLETE TURN IS MADE TO AVOID SERIOUS DAMAGES TO THE MOUNTING CLAMP AND TO THE RIM.

WARNING!

RECOMMENDED PROCEDURES REQUIRE THAT TRUCK TIRES BE INFLATED TO NO MORE THAN 3-5 PSI FOR BEAD SEATING PURPOSES, OF MULTI-PIECE AND SINGLE PIECE ASSEMBLY RESPECTIVELY. FOR CONTINUED INFLATION THE ASSEMBLY MUST BE PLACED IN AN APPROVED INFLATION RESTRAINT DEVICE (IN THE UNITED STATES OF AMERICA CONSULT O.S.H.A. REGULATIONS CONCERNING THE PROPER SERVICING OF TRUCK WHEELS AND RIMS).

5.4 Demounting Tires from Multi-Pieces Rim/Wheel Assemblies

The multi-piece rim/wheel assembly can be in two or more pieces (Fig.29).

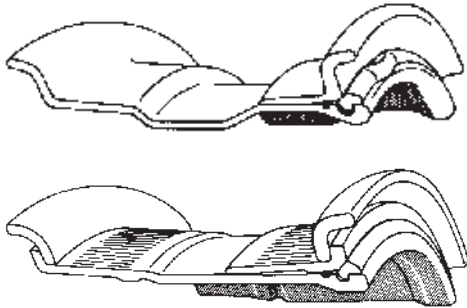

Fig.29

424 - 425

The truck wheels are normally in 2 pieces and are always tube-type.

In two piece assemblies the rim flange and the lock ring are one piece and the rim base is the other.

In three piece assemblies the lock ring rim flange and rim base are the effected components.

In this case the rim flange goes on after the tire and is held in place by the locking.

1. Position the bead-breaker disc close to the rim edge (Fig.30).

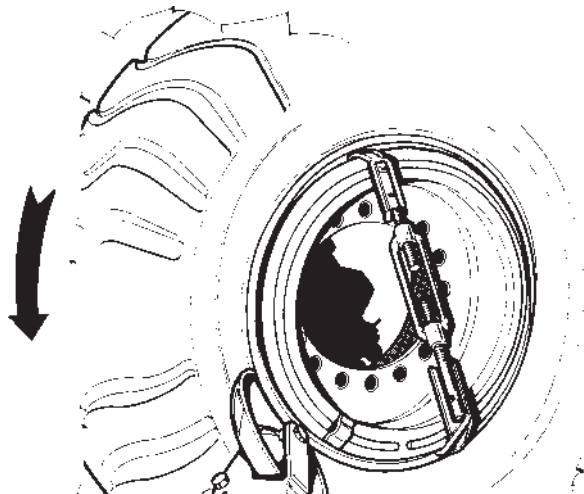

Fig.30

426

2. Turn the chuck counter-clockwise and the bead as described in chapter 5.0.1 - 5.0.2. Do not lubricate.

3. To remove the lock ring, squeeze one edge with the proper bar and place the bead breaker disc as shown in Fig.31.

Fig.31

587

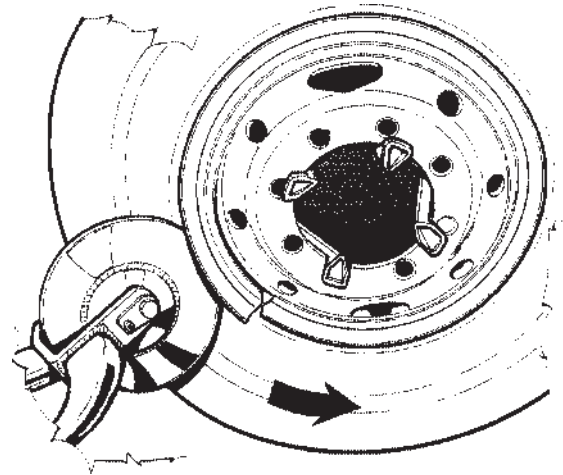

4. Turn the chuck clockwise (or counter-clockwise) until the lock ring is completely removed

WARNING!

NO ONE SHOULD STAND IN FRONT OF THE WHEEL WHEN REMOVING THE LOCK RING.

Continue to demount manually or with the bead breaker disc all components of the rim.

5. When breaking the inner bead be sure not to damage the valve stem (Fig.32).

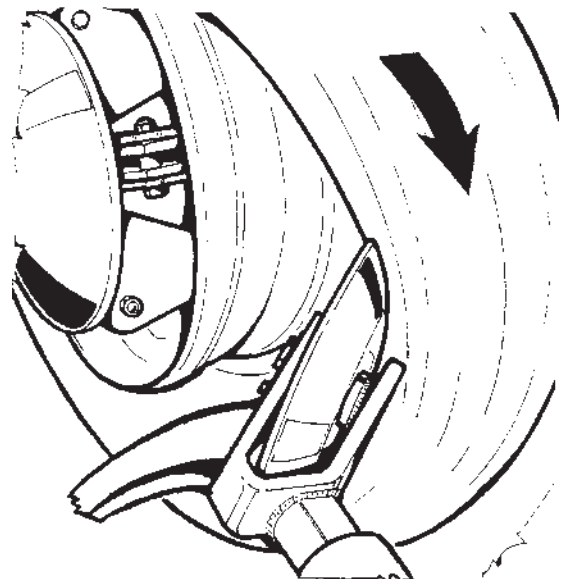

Fig.32

580

5.5 Mounting Tires onto Multi-Pieces Rim/Wheel Assemblies

1. Move the footboard all the way out. Roll the tire on the footboard (the tube and flap must be in place).

For tube type only the valve should be placed at 12 o'clock, for easier mounting.

2. Slide the tire onto the rim with the footboard or with the bead breaker disc, if necessary.

3. Mount all the assembly components (Fig.33).

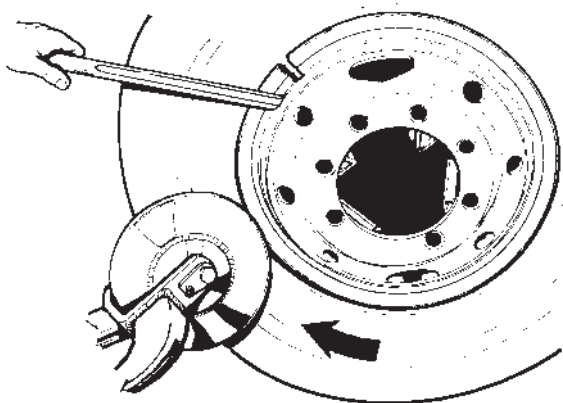

Fig.33

588

4. Engage one edge of the lock ring in its seat and complete the mounting process with the bead breaker disc.

In the initial mounting phase hold the rim edge in its seat with a bar.

WARNING!

RECOMMENDED PROCEDURES REQUIRE THAT TRUCK TIRES BE INFLATED TO NO MORE THAN 3-5 PSI FOR BEAD SEATING PURPOSES, OF MULTI-PIECE AND SINGLE PIECE ASSEMBLY RESPECTIVELY. FOR CONTINUED INFLATION THE ASSEMBLY MUST BE PLACED IN AN APPROVED INFLATION RESTRAINT DEVICE (IN THE UNITED STATES OF AMERICA CONSULT O.S.H.A. REGULATIONS CONCERNING THE PROPER SERVICING OF TRUCK WHEELS AND RIMS).

6.0 Maintenance

The ACCU model 4260 does not require any specific maintenance but the following precautions are necessary:

1. Lubricate all points provided with a greasing nipple once a month (Fig.35).

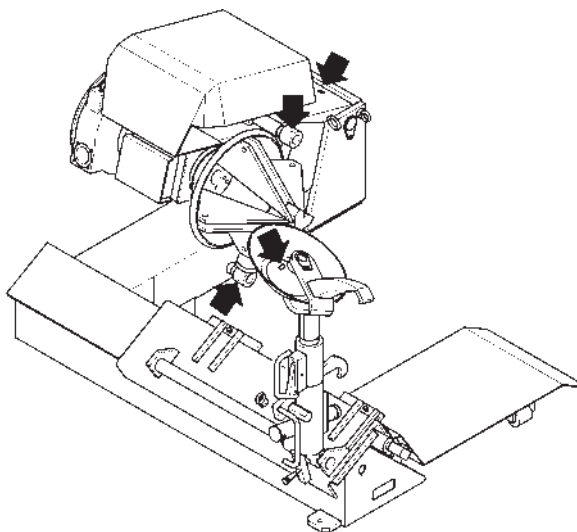

Fig.35

848

2. Check gear oil once a week (Fig. 36). The chuck arm should be completely lowered when the check is performed.

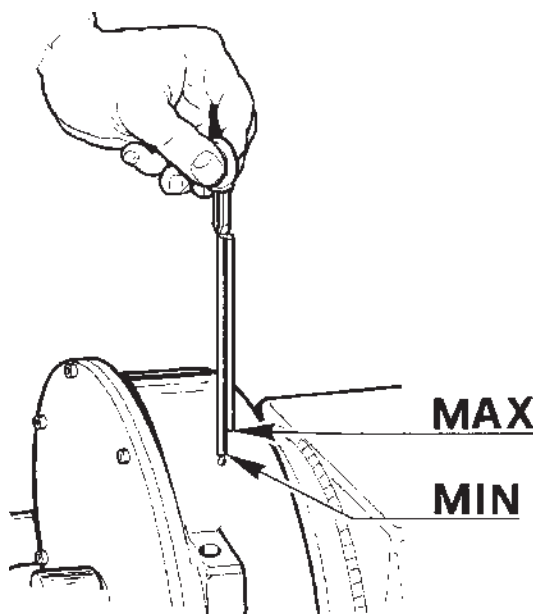

Fig. 36

597

If necessary add:

ESSO: Gear Oil gx 85 W 90 (or 80 W 90)
 SHELL : Spirax HP 85 W 90
 TOTAL : EP SAE 85 W 90

Change gear oil once a year. Oil sump capacity is 0.3 gal (1.5 lt). Add 5% of disulphide of molybdenum (UNIMOLY S6).

3. Check hydraulic oil level once a month.

NOTE:

BEFORE CHECKING, ALL CYLINDERS MUST BE COMPLETELY RETRACTED.

If necessary add:

ESSO: Nuto H 46
 SHELL : Tellus oil 46
 TOTAL : Azolla 46

Oil change is not required.

4. Clean and grease the tool holder slide cylinder once a month (Fig. 37).

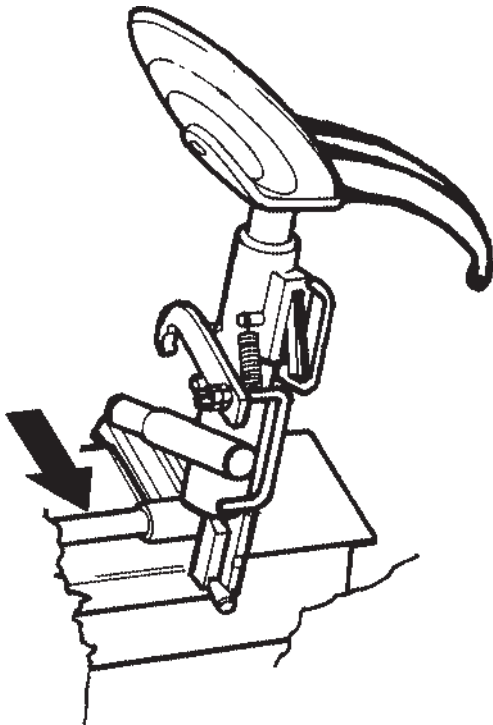

Fig. 37

611

5. Clean the jaws once a month with a steel brush.

7.0 Trouble Shooting

WARNING!

BEFORE ANY REPAIRS ARE PERFORMED YOU MUST ENSURE THAT NO WHEEL IS MOUNTED ON THE CHUCK AND THAT THE MACHINE IS DISCONNECTED FROM THE ELECTRIC SUPPLY.

TROUBLE

POSSIBLE CAUSE

- | | |
|--|---|
| 1. Pump motor turns but none of the hydraulic movements works. | Check automatic switch.
Check the phuses.
Check the terminal switch. |
| 2. Pump motor does not turn but the chuck motor operates normally. | Check the terminal switch that protects the pump motor. |
| 3. The thermal switch that protects the pump motor is very easily activated. | Check the input voltage under load. |
| 4. The automatic switch blows very often. | Check if the machine is stable on the floor. Check that the electronic box is firmly fitted and does not vibrate. |
| 5. The transformer protection phuses (4A) easily blow. | Check that the cord between the machine and the remote control is not interrupted. |
| 6. The wheel falls while bead breaking. | Check the wear status of the jaws. Check that there is no oil leak in the bottom of the self-centering chuck. |



SPARE PARTS EXPLODED VIEWS

Electric-Hydraulic Tire Changer
for Truck Wheels

ACCU 4260

Rev.:B

- **On order specify:** type of machine and serial number item code and quantity.
- **A la commande:** bien préciser le type de la machine, le n° de série, la référence de pièce, la quantité.
- **En cada pedido hay que especificar:** el tipo de maquina y su numero de matricula, el numero de código de la pieza requerida y su cantidad.
- **All'ordine specificare:** tipo macchina e matricola, codice e quantità del particolare.
- **Bei Auftragserteilung anzugeben:** Maschinentype, Serinnummer, Artikelcode, Menge.
- **En cada pedido hay que especificar:** el tipo de màquina y su nùmero de matrícula, el nùmero de còdigo de la pieza requerida y su cantidad.
- **Specificeer op een order:** machine type en serienummer, artikelnummer en aantal.
- **Vid order specificisera:** Maskin typ och serie nr reservdels nr ochantal.



THIS PART IS FOR EXCLUSIVE USE OF QUALIFIED PERSONNEL FOR MAINTENANCE AND SERVICE PURPOSES.

CETTE PARTIE EST RESERVEE AU PERSONNEL QUALIFIE ET AUTORISE A LA MAINTENANCE ET AU SERVICE APRES-VENTE.

ESTA PARTE ES PARA USO EXCLUSIVO DEL PERSONAL CALIFICADO Y AUTORIZADO PARA EL MANTENIMIENTO Y LA ASISTENCIA.
QUESTA PARTE È AD USO ESCLUSIVO DEL PERSONALE QUALIFICATO ED AUTORIZZATO ALLA MANUTENZIONE ED ASSISTENZA.

ESTA PARTE ES PARA USO EXCLUSIVO POR PESSOAL ESPECIALIZADO ED AUTORIZADO A LA MANUTENÇÃO

DIESER ABSCHNITT IST AUSSCHLISSLICH DEM WARTUNGSFACH-UND KUNDENDIENSTPERSONAL VORBEHALTEN

DENNE DEL ER BEREGNET TIL BRUK FOR KVALIFISERT PERSONALE FOR VEDLIKEHOLD OG SERVICE
DIT GEDEELTE IS ALLEEN BESTEMD VOOR BEVOEGDE PERSONEN VOOR ONDERHOUD EN SERVICE DOELEINDEN

DENNA DEL ÄR ENBART TILL FÖR UTBILDAD PERSONAL VID UNDERHÅLLS- OCH SERVICEARBETEN DENNE DEL ER KUN BEREGNET TIL BRUG FOR FAGLÆRTE OG FOLK SOM ER KVALIFICERET OG AUTORISERET TIL VEDLIGEHOELSE OG SERVICE

TÄMÄ OSA ON TARKOITETTU AINOASTAAN VALTUUTETUN HUOLTOHENKILÖSTÖN KÄYTTÖÖN HUOLTOTARKOITUKSIIN

ΑΥΤΟ ΤΟ ΜΕΡΟΣ ΕΙΝΑΙ ΓΙΑ ΤΗΝ ΑΠΟΚΛΕΙΣΤΙΚΗ ΧΡΗΣΗ ΕΚ ΜΕΡΟΥΣ ΕΞΟΥΣΙΟΔΟΤΗΜΕΝΟΥ ΙΚΑΝΟΥ ΠΡΟΣΩΠΙΚΟΥ ΓΙΑ ΕΡΓΑΣΙΕΣ ΣΥΝΤΗΡΗΣΗΣ ΚΑΙ ΕΠΙΣΚΕΥΗΣ

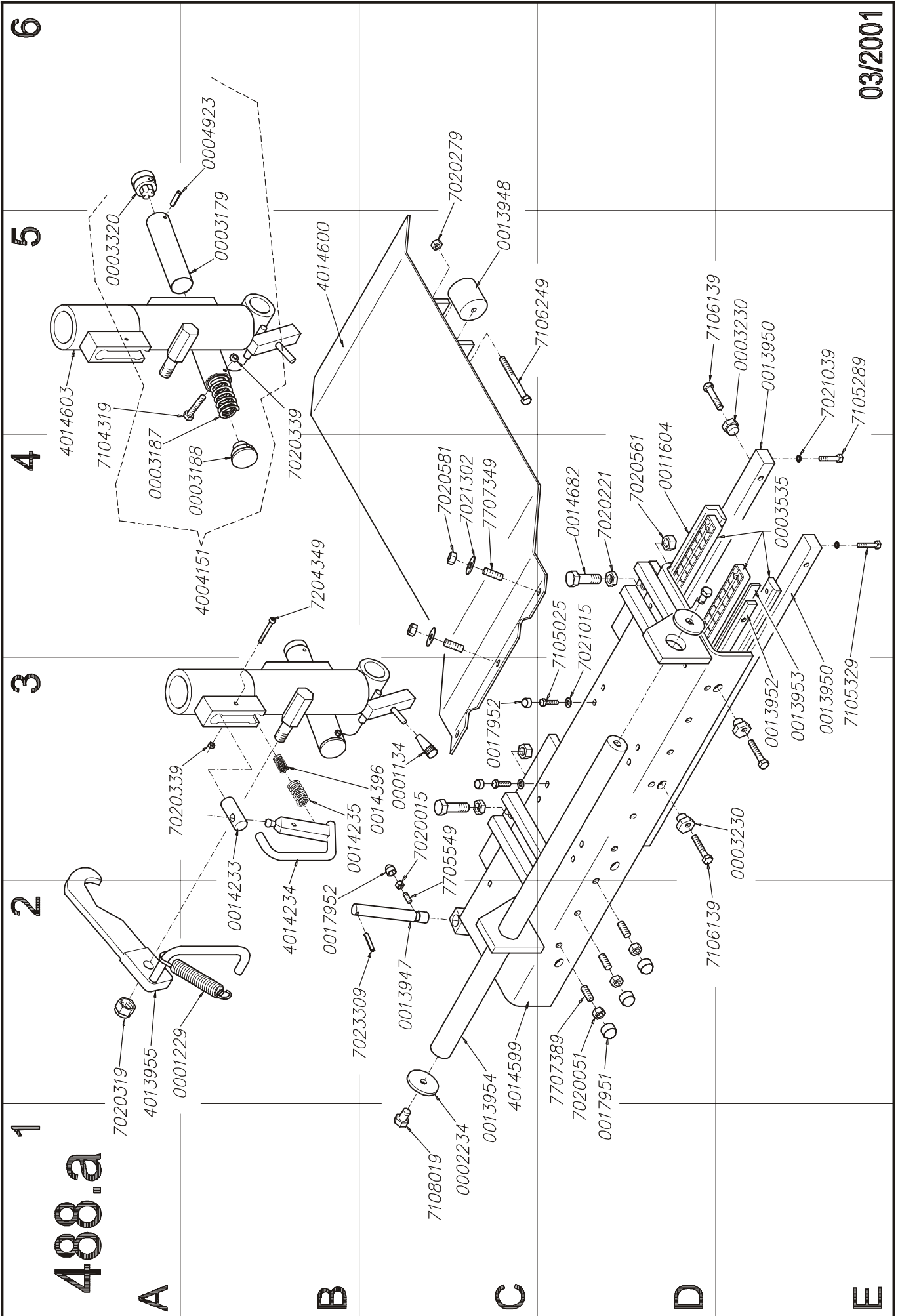

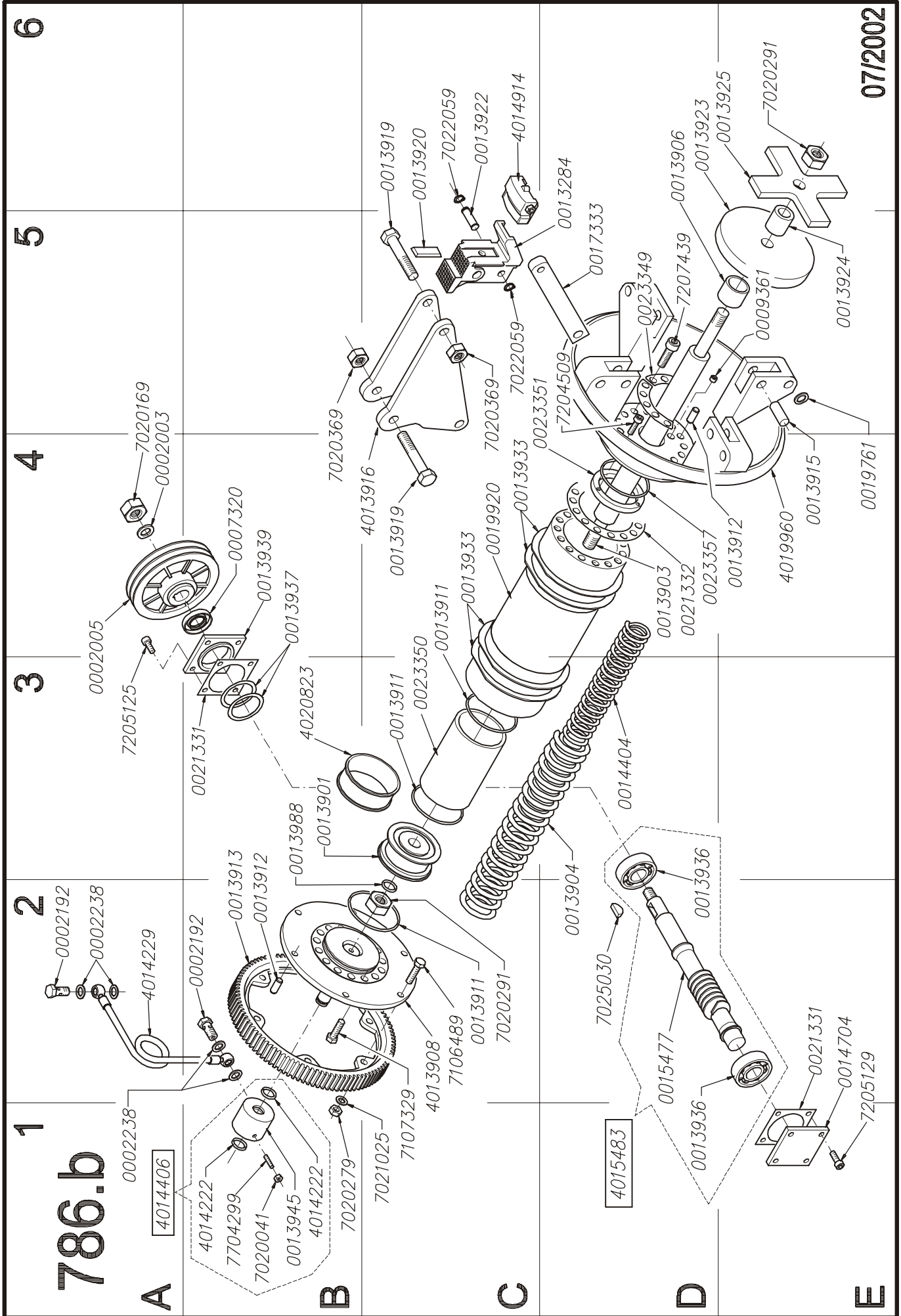

07/2002

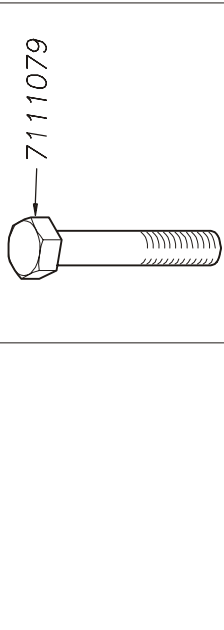
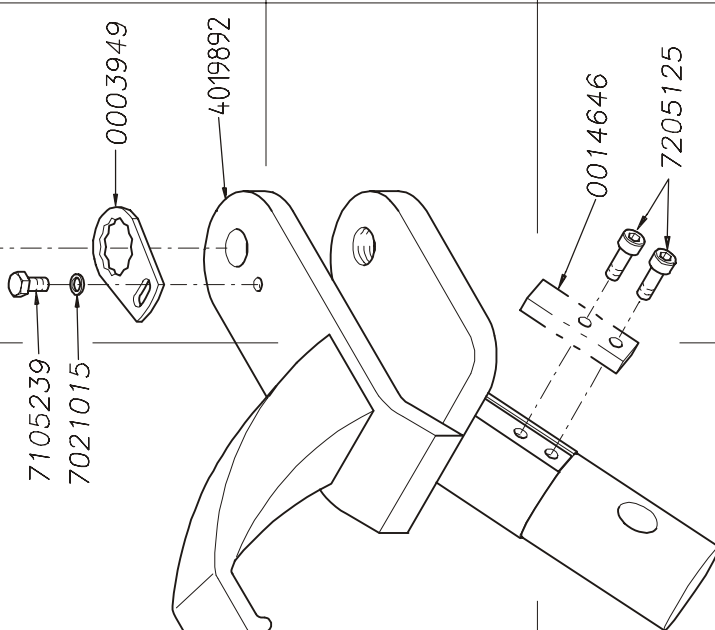
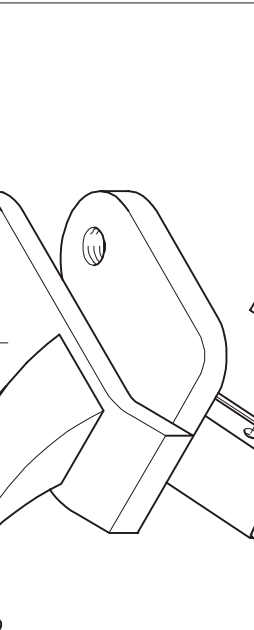
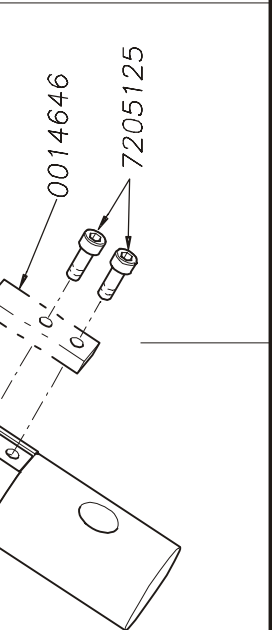
<p>1 490.a A</p>	<p>2</p>	<p>3</p>	<p>4</p>	<p>5 6</p>
<p>1</p>	 <p>7111079 7105239 7021015 4019892</p>	 <p>0003949 4019892 0014646 7205125</p>	 <p>4018934 0018936 0007808</p>	 <p>0007808 0018936 0004918 0003280 0018936 0007808</p>
<p>490.a</p>	<p>490.a</p>	<p>490.a</p>	<p>490.a</p>	<p>490.a</p>
<p>490.a</p>	<p>490.a</p>	<p>490.a</p>	<p>490.a</p>	<p>490.a</p>

4019891

03/2001

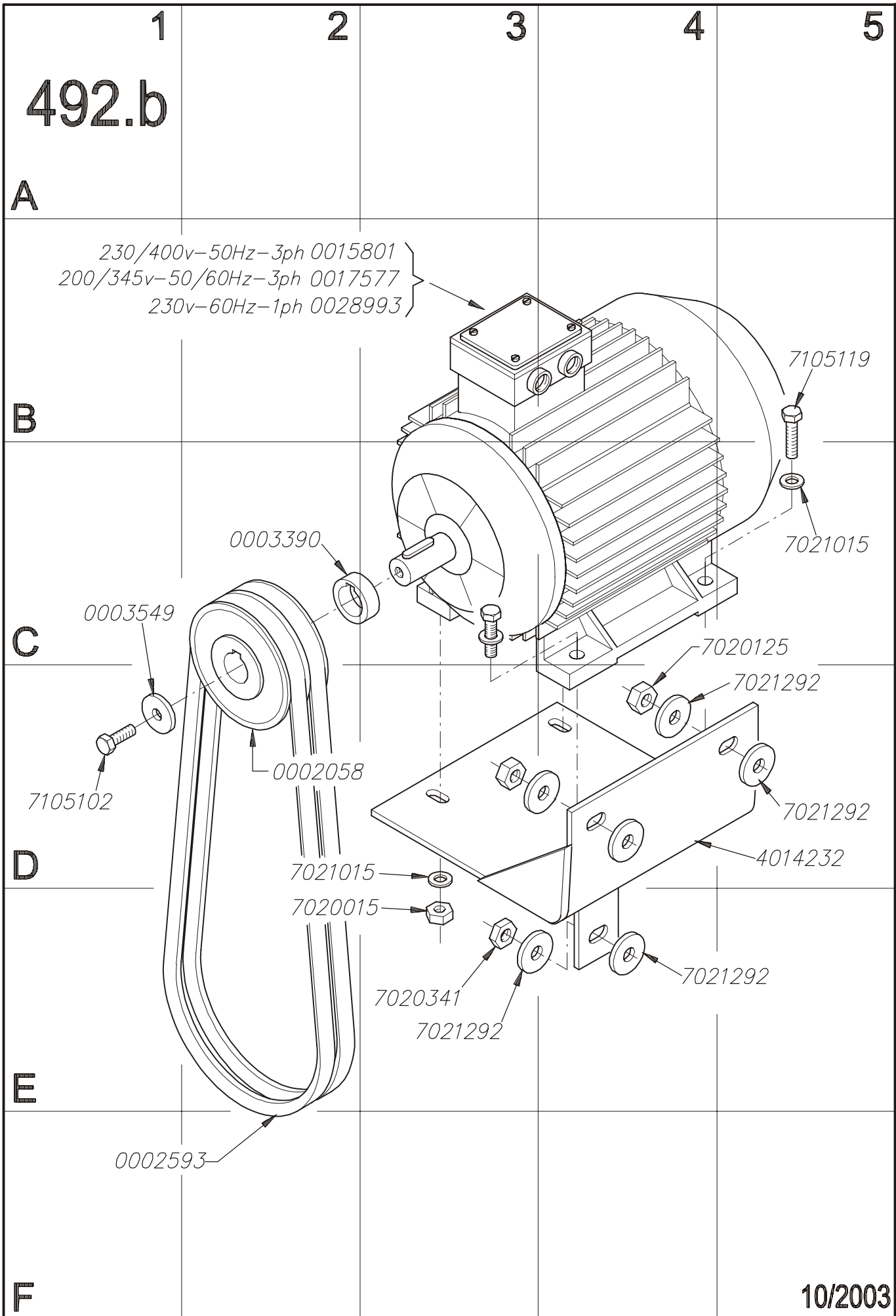

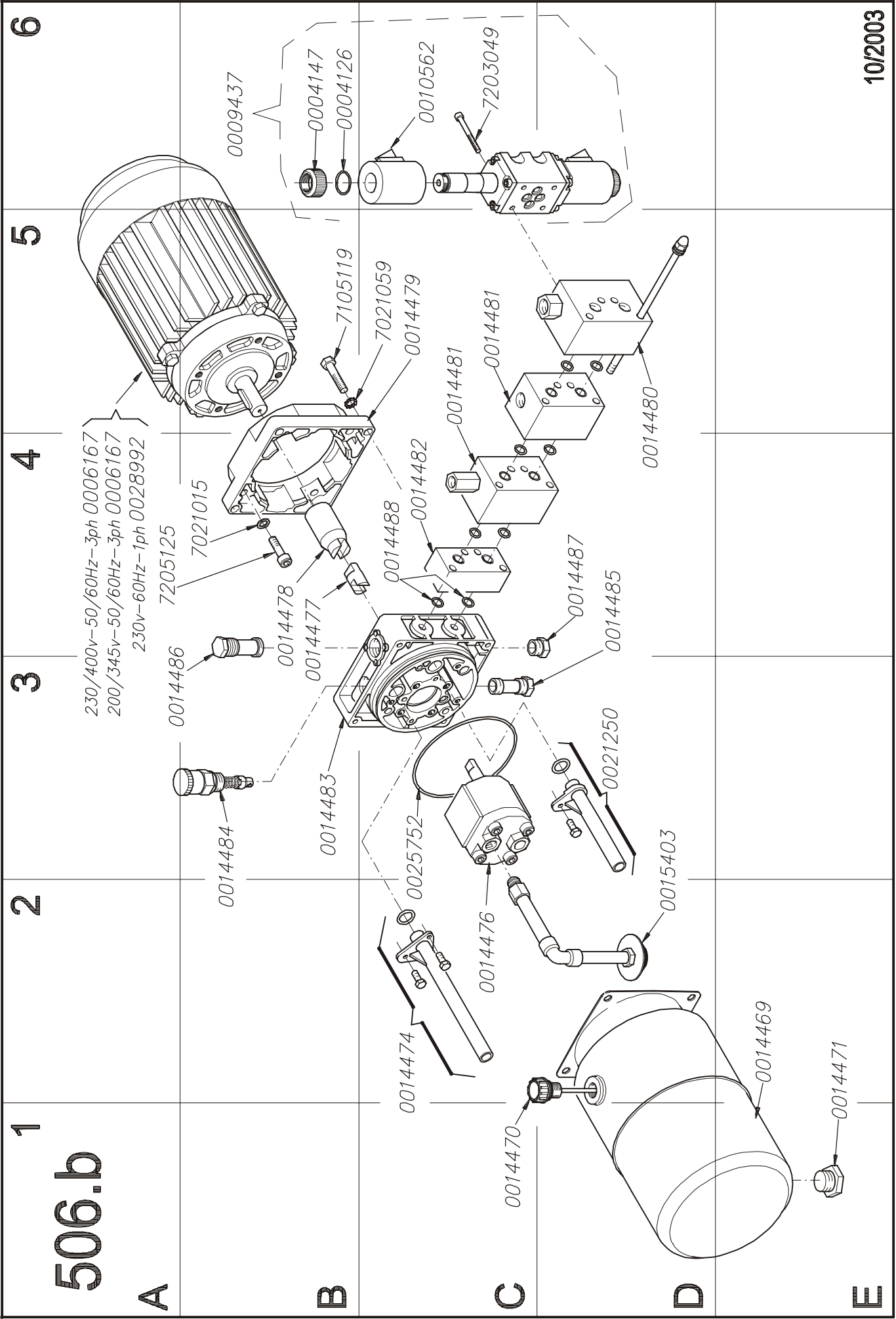

10/2003

155-b-Oct-03

1329

1

2

3

4

5

A

B

C

D

E

F

4015712

7413023

0005039

7414043

0003422

4006043

0005039

7414051

0004617

7413023

4014408

7021119

7104119

7021119

7104119

0002562

4014585

4002196

0002199

0002200

0002072

7302032

0022435

7020091

7022059

0002051

7022059

4013119

4002197

4014604

10/2003

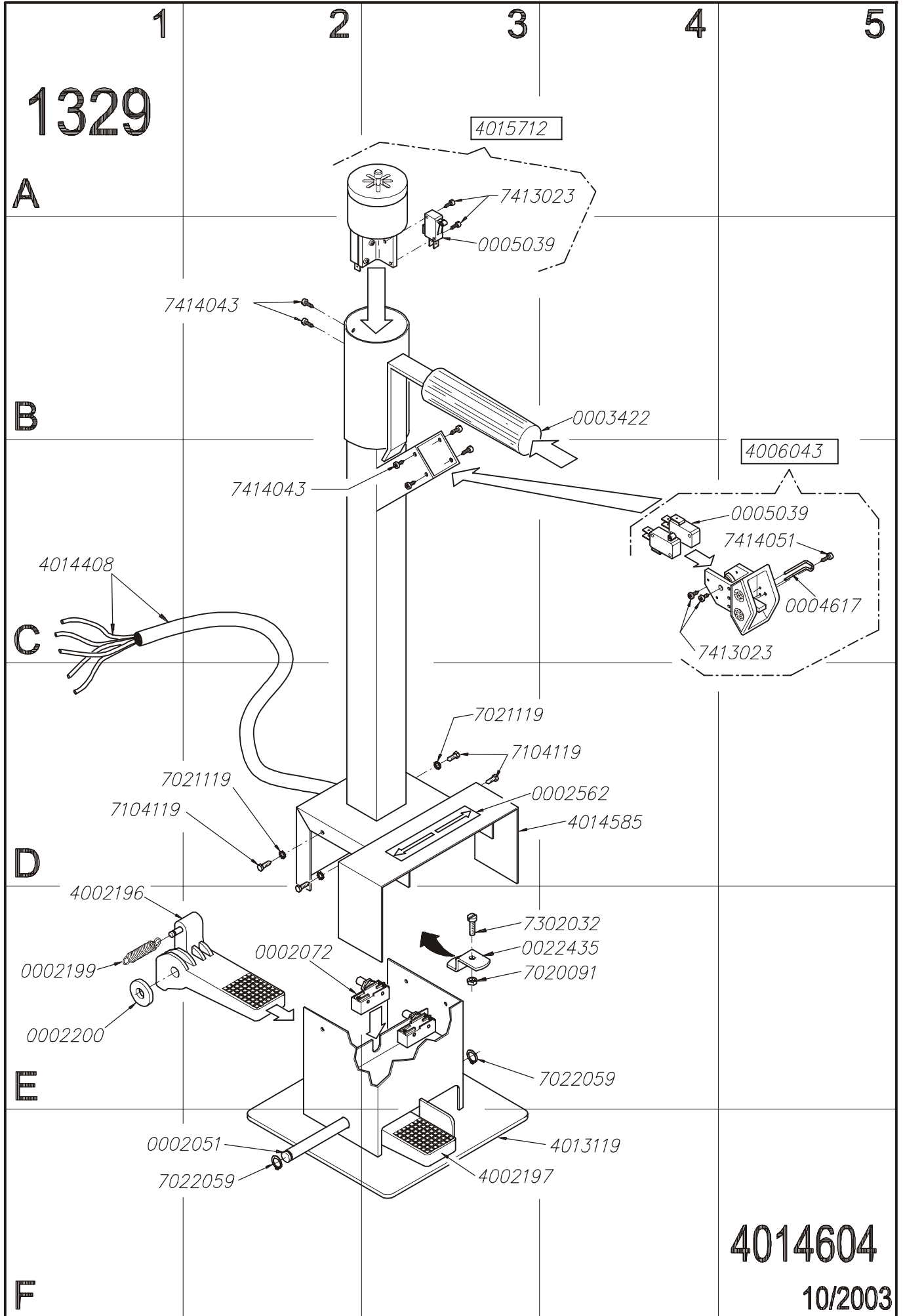

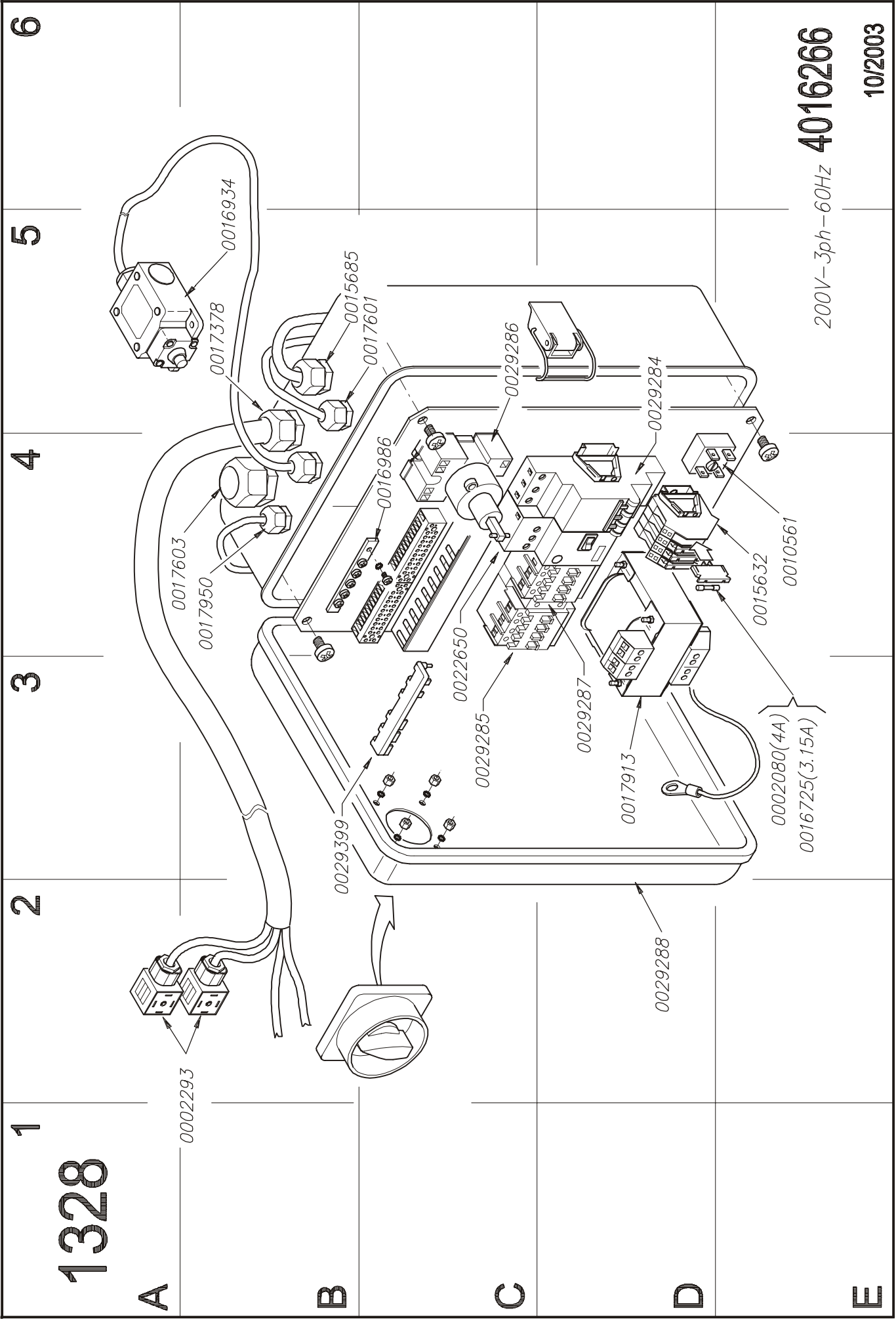

200V-3ph-60Hz **4016266**

10/2003

RIFERIMENTO QUERVENNIS REFERENCE	
IDRAULICO HYDRAULIK HYDRAULIQUE	ELETTTRICO ELEKTRIK ELECTRIQUE
1.1	Y3B / Y3N
2.1	Y2B / Y2N
3.1	Y1B / Y1N

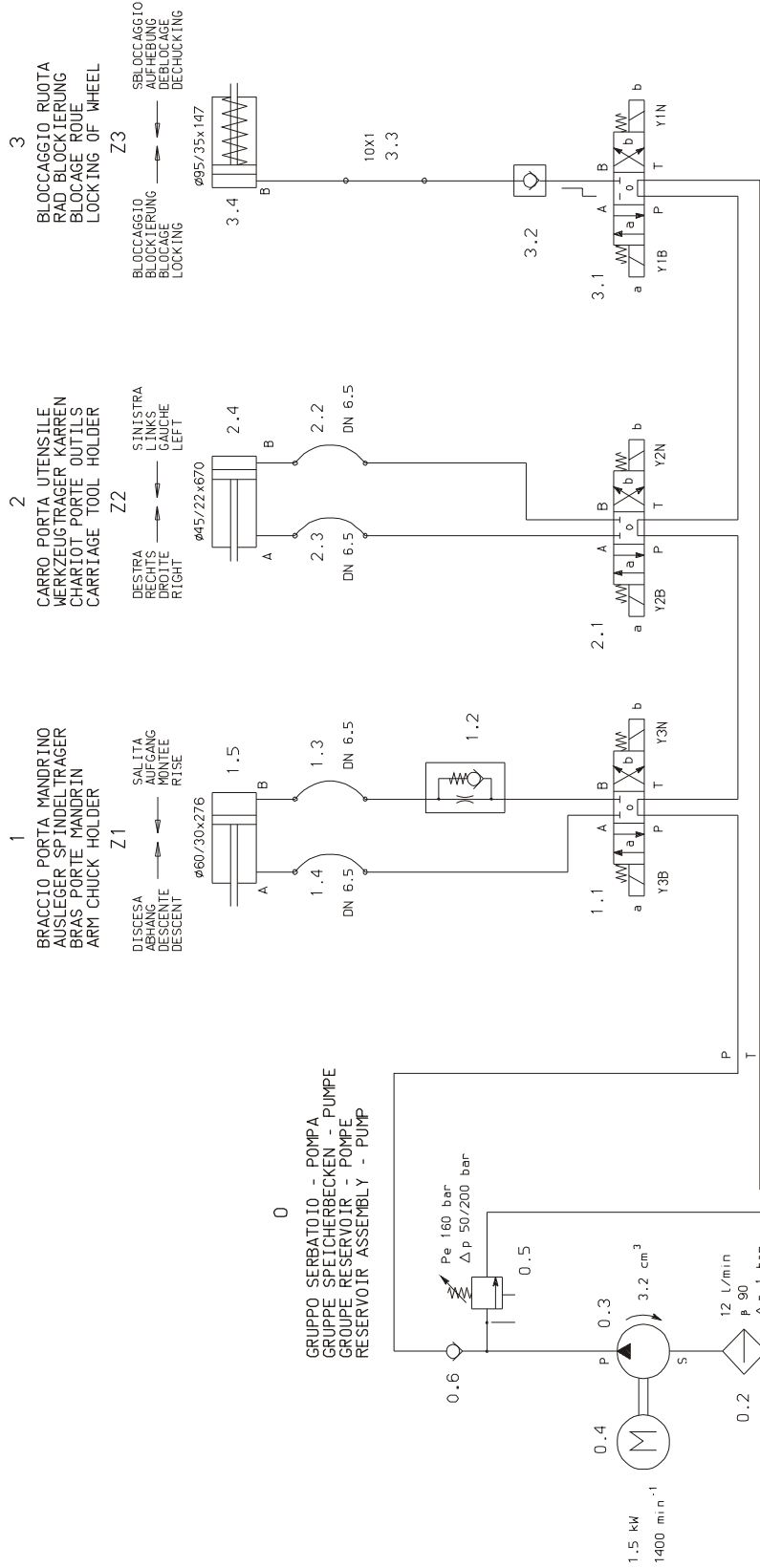

GRUPPO GRUPPE GROUPE GROUP	PAGINA BLATT PAGE PAGE	N°. N°. N°. N°.	PAGINE BLATT DE DE PAGES PAGES	CLIENTE BESTELLER CLIENT CUSTOMER	FIRMA GEZ. SIGNATURE	COMPAGNI D.	DATA DATUM DATE	VISTO GEPRÜFT CONTROLÉ PAR	SCHEMA HYDRAULISCHEN EINRICHTUNG BK 2600 SCHEMA INSTALLATION HYDRAULIQUE BK 2600 SCHEMA HYDRAULIC INSTALLATION BK 2600
					CONSTRUITO IN FABRIKAT IN MADE	ITALY	TIPO MODEL	2600	DATA DATUM DATE
N°.				MODIFICA ÄNDERUNG	MODIFICATION	CHANGE	DATA DATUM DATE	NOME NAME	

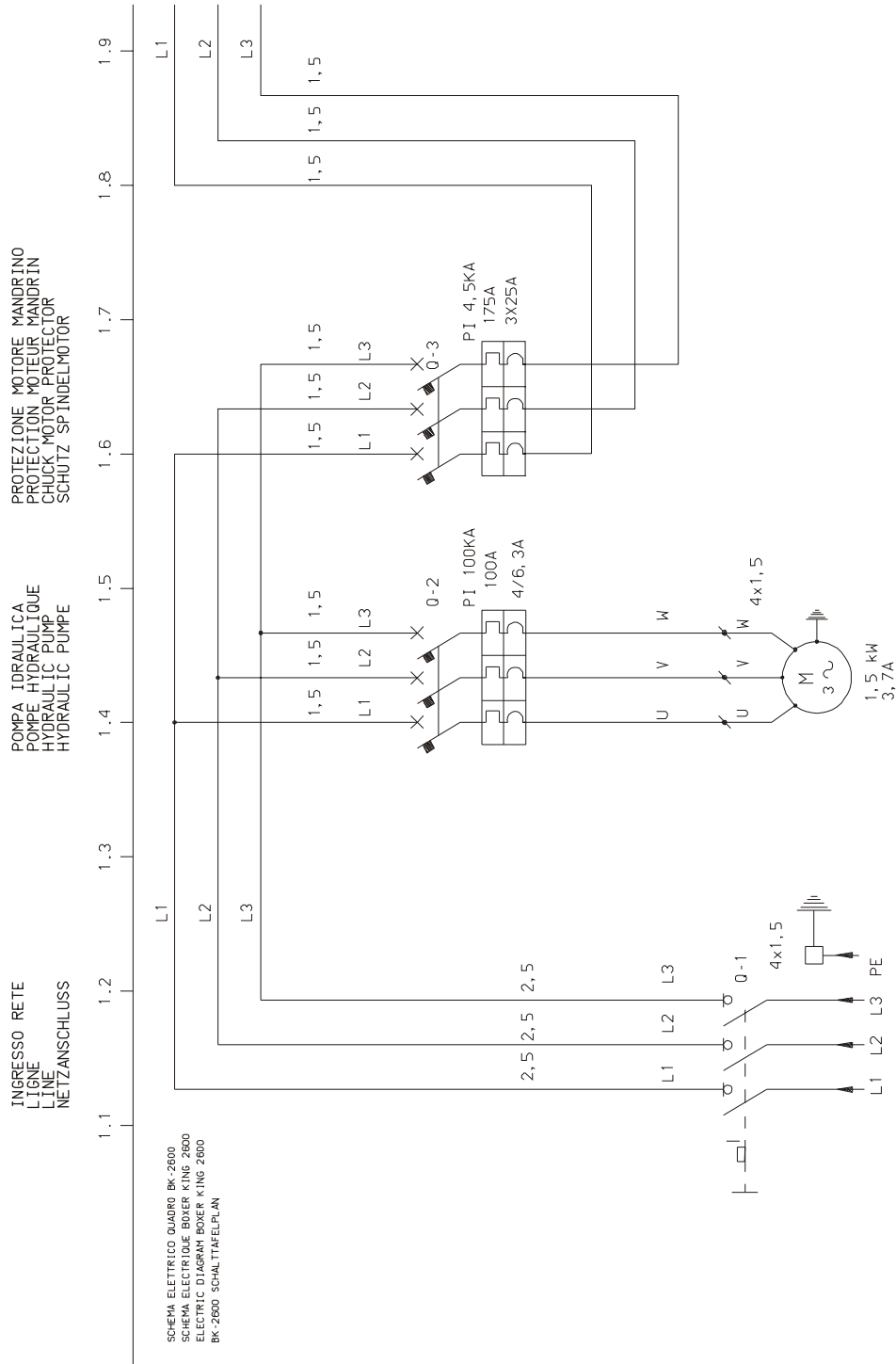

ORIGINE : CODICE NT 941301	
GRUPPO PARTI GROUPE GROUP	PAGINA PARTI PAGE PAGE
1	6
CLIENTE BESTELLER CLIENT CUSTOMER	
FIRMA GEZ. SIGNATURE COMPAGNI D.	
DATA DATUM DATE 17-03-94	
COSTRUITO IN FABRIQUE EN ITALY	
TIPO TYP MODELE MODEL 2600	
CODICE MACCHINA INVENTAR N°. MACHINE REF. CODE MACHINE	
05-09-97	FUSARI
DATA DATUM DATE	NOME NAME
VEDI TABELLA	
MODIFICA AENDERUNG MODIFICATION CHANGE	
1	SCHEMA ELETTRICO BK 2600 SCHEMA ELECTRIQUE BK 2600 ELECTRIC DIAGRAM BK 2600 SCHALTAFELPLAN BK 2600
N°.	FAMIGLIA 824
	ZEICHNUNGS N°. 0016637

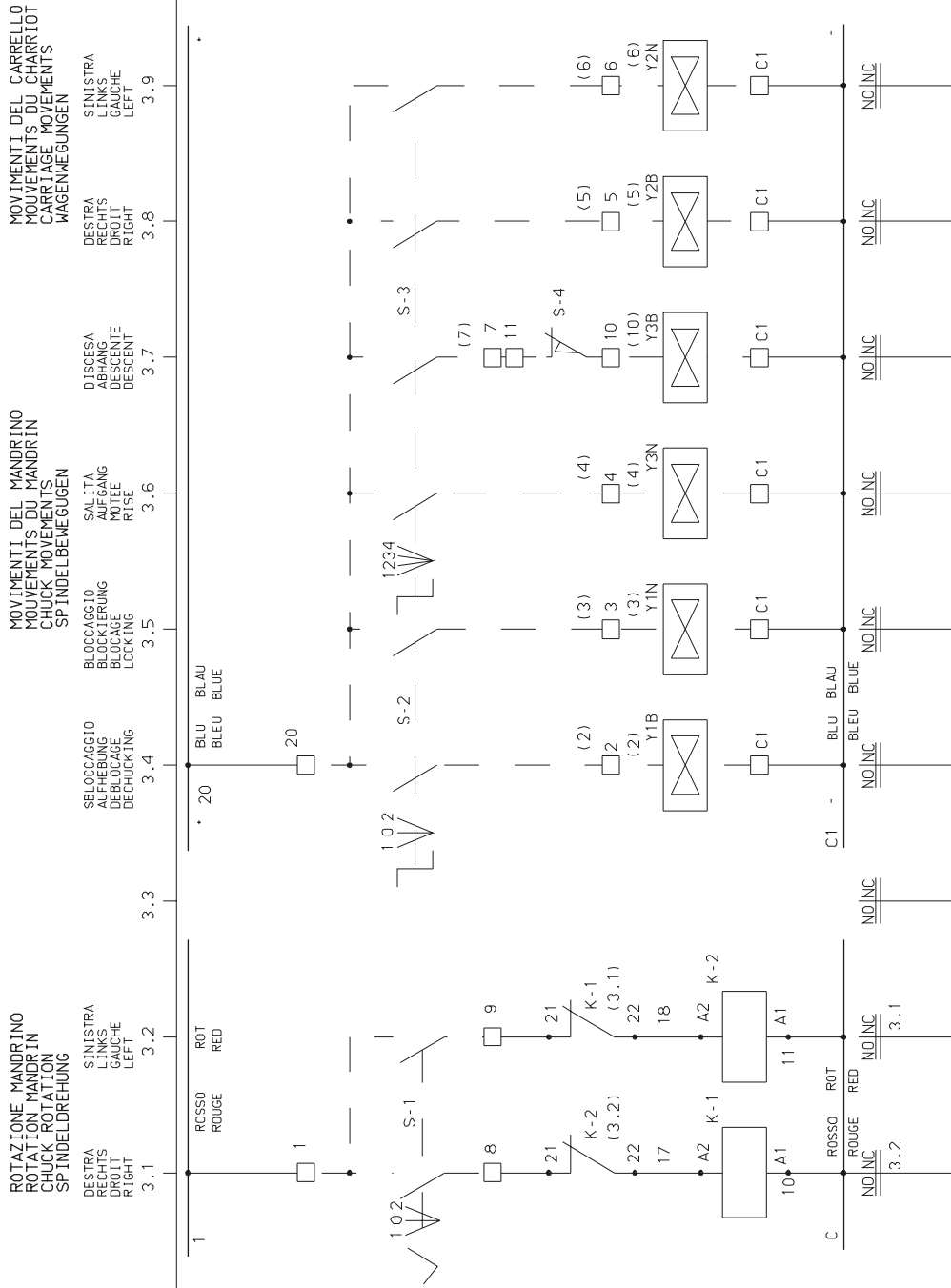

ROTAZIONE MANDRINO
 ROTATION MANDRIN
 CHUCK ROTATION
 SPINDELDREHUNG
 DESTRA RECHTS DROIT RIGHT 3.1
 SINISTRA LINKS GAUCHE LEFT 3.2
 ROSSO ROT RED 3.2
 BLU BLAU BLEU BLUE 3.3

MOVIMENTI DEL MANDRINO
 MOVEMENTS DU MANDRIN
 CHUCK MOVEMENTS
 SPINDELBEWEGUNG
 SBLOCCAGGIO UNLOCKING 3.4
 BLOCCAGGIO LOCKING 3.5
 SALITA AUFGANG RISE 3.6
 DISCESA ABHANG DESCENT 3.7
 DESTRA RECHTS DROIT RIGHT 3.8
 SINISTRA LINKS GAUCHE LEFT 3.9

MOVIMENTI DEL CARRELLO
 MOVEMENTS DU CHARRIOT
 CARRIAGE MOVEMENTS
 WAGENBEWEGUNG
 DESTRA RECHTS DROIT RIGHT 3.8
 SINISTRA LINKS GAUCHE LEFT 3.9

GRUPPO PAGINA PARTI PAGE GROUPE DE PAGES GROUP Nr. OF PAGES 3		ORIGINE : CODICE NT 941303	
CLIENTE BESTELLER CLIENT CUSTOMER NF. ORDINE AUFTRAG-Nr. COMMANDE Nr. P.D. NUMBER		CODICE Nr. ZEICHNUNGS Nr. CODE 0016637	
FIRMA GEZ. SIGNATURE COMPAGNI D. DATA DATUM DATE 17-03-94		SCHEMA ELETTRICO BK 2600 SCHEMA ELECTRIQUE BK 2600 ELECTRIC DIAGRAM BK 2600 SCHALT TAFELPLAN BK 2600	
COSTRUITO IN FABRIKAT IN FABRIQUE EN MADE ITALY		TIPO MODELLO MODEL 2600	
CODICE MACCHINA INVENTAR Nr. MACHINE REF. CODE MACHINE		DATA DATUM DATE 05-09-97	
VISTO GEPRUFT CONTROLLE PAR TESTED BY FUSARI		NOMI NOME NAME DATE	
MODIFICA AENDERUNG MODIFICATION CHANGE		VEDI TABELLA	

MORSETTIERA QUADRO ELETRICO BK-2600
 BLOC TERMINAL ARMOIRE ELECTRIQUE BX 2600
 TERMINAL BLOC-ELECTRIC CABINET BX 2600
 BOXER KING 2600 KLEMMLEISTE SCHALTPLAN

5.1 5.2 5.3 5.4 5.5 5.6 5.7 5.8 5.9

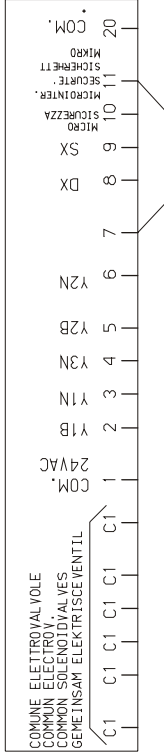

NO/NC	NO/NC	NO/NC	NO/NC	NO/NC	NO/NC	NO/NC	NO/NC	NO/NC	NO/NC
-------	-------	-------	-------	-------	-------	-------	-------	-------	-------

GRUPPO PARTI GROUPE GROUP		PAGINA PARTI PAGE PAGE		ORIGINE : CODICE NT 941305	
N° . PARTI N° . DE PAGES N° . OF PAGES		5		6	
CLIENTE BESTELLER CLIENT CUSTOMER		FIRMA GEZ. SIGNATURE COMPAGNI D.		N° . ORDINE AUFTRAG-N° . COMMANDE N° . P.D.NUMBER	
N° . ORDINE AUFTRAG-N° . COMMANDE N° . P.D.NUMBER		DATA DATUM DATE 17 - 03 - 94		SCHEMA ELETRICO BK 2600 SCHEMA ELECTRIQUE BK 2600 ELECTRIC DIAGRAM BK 2600 SCHALT TAFELPLAN BK 2600	
CODICE N° . FAMIGLIA		VISITO GEPRIIFT CONTROLE PAR TESTED BY		CODICE N° . ZEICHNUNGS N° . FAMIGLIA	
824		FUSARI		0016637	
MODIFICA AENDERUNG MODIFICATION CHANGE		DATA DATUM DATE 05-09-97		NOME NAME FUSARI	
VEDI TABELLA		TIPO TYP MODELE MODEL 2600		CODICE MACCHINA INVENTAR N° . MACHINE REF . CODE MACHINE	
1		ITALY		COSTRUITO IN FABRIKAT IN FABRIQUE EN MADE	
N° .		COMPAGNI D.		FIRMA GEZ. SIGNATURE COMPAGNI D.	

Revision B		Differences on previous version.
OPERATOR'S MANUAL		
<ul style="list-style-type: none"> - New document layout. - Updated pictures near the text 		
SPARE PARTS:		
<ul style="list-style-type: none"> - Tables (Exploded view) 		
OLD	UPDATED	ADDED
- 266	- 496	- 492.b
- 267	- 488.a	- 535
- 268	- 786.b	- Electric Diagram 16637
- 269	- 506.a	- Hydraulic Diagram 15881
- 270	- 490.a	
- 271	- 1328	
- 272	- 1329	

USA

Accu Industries, Inc

P.O. Box 15540 / Richmond, Va. 23227
11126 Air Park Road / Ashland, Va. 23005
phone: 804.798.8922
toll free: 1.800.551.2228
fax: 804.798.6742



Notice: The information contained in this document is subject to change without notice. **ACCU-TURN Company** shall not be liable for errors contained herein or for incidental consequential damages in connection with furnishings, performance, or use of this material.

This document contains proprietary information which is protected by copyright and patents. All rights are reserved. No part of this document may be photocopied, reproduced, or translated without prior written consent of **ACCU-TURN Company**.

Updated...10/2003...copyright 2003 - gft...**Rev.B**

Printed in the USA



ACCU 4260