

Accu Industries, Inc.®

ACCU 3501

**ALL AIR TIRE CHANGER FOR
CAR, LIGHT TRUCK AND
MOTORCYCLE WHEELS.**

**OPERATOR'S MANUALSPARE PARTS
EXPLODED DRAWINGS**

TABLE OF CONTENTS

1.0 INTRODUCTION Page 4

1.1 NOMENCLATURE Page 4

1.2 SPECIFICATIONS Page 4

1.3 STANDARD ACCESSORIES Page 5

1.4 OPTIONAL ACCESSORIES Page 6

1.5 GENERAL PRECAUTIONS Page 6

2.0 INSTALLATION Page 7

2.1 AIR INSTALLATION Page 8

3.0 CONTROLS Page 8

4.0 MOUNTING AND DEMOUNTING TIPS Page 9

4.1 DEMOUNTING TUBELESS TIRES Page 9

4.2 MOUNTING TUBELESS TIRES Page 11

4.3 INFLATING TUBELESS TIRES Page 13

5.0 DEMOUNTING TUBE TYPE TIRES Page 14

5.1 MOUNTING TUBE TYPE TIRES Page 14

5.2 INFLATING TUBE TYPE TIRES Page 15

6.0 MOUNTING AND DEMOUNTING MOTORCYCLE TIRES Page 15

7.0 MAINTENANCE Page 16

1.0 INTRODUCTION

Congratulations on purchasing the ACCU Model 3501 air tire changer.

This tire changer is designed for ease of operation, safe handling of rims, reliability and speed. This combination of features means more profit and added versatility for your shop, enabling you to work with aluminum or magnesium alloy wheels without damaging a customer's rim.

With a minimum of maintenance and care your ACCU Model 3501 will provide many years of trouble-free operation.

Please read this manual thoroughly before operating the unit. Instructions on use, maintenance and operational requirements of the machine are covered in this manual.

1.1 NOMENCLATURE

Before installing and using the ACCU Model 3501 it is suggested that you become familiar with the nomenclatures of the machine's components.

- | | |
|-----------------------|--------------------------------|
| 1. Vertical slide | 9. Bead breaker arm |
| 2. Swing arm | 10. Bead breaker blade |
| 3. Adjustment knob | 11. Bead breaker pads |
| 4. Lock lever | 12. Foot pedal controls |
| 5. Mount/demount tool | 13. Inflation gauge |
| 6. Tower or column | 14. Bead seater/inflator pedal |
| 7. Turntable | 15. Air jets |
| 8. Jaw | |

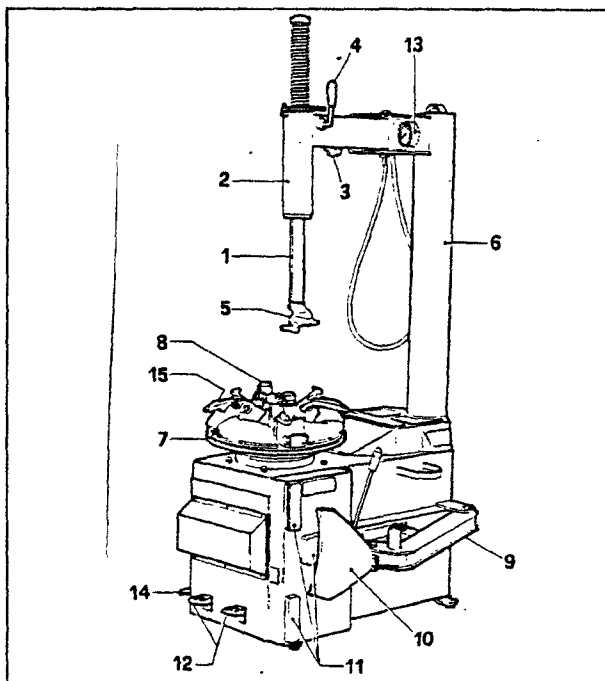

Fig.1

1.2 SPECIFICATIONS

All air tire changer for car, light commercial vehicle and motorcycle tires designed for one-piece rims.

- Weight lbs 484 (kg 220)
- Air pressure required psi 110-170 (bar 8-12)
- Bead breaker force lbs 3630 (kN 16.5)
- Max. turntable torque ftxlb 650 (Nm 900)
- Max. tire diameter 40" (mm 1015)
- Max. rim width 14" (mm 356)
- Rim diam. outside locking 10"-18"
- Rim diam. inside locking 12"-20"
- Rim diam. outside locking with adapters 8"-16"
- Motorcycle wheels with adapters 15"-23"

The maximum torque and speed of the turntable are influenced by the air pressure as shown in Fig.2.

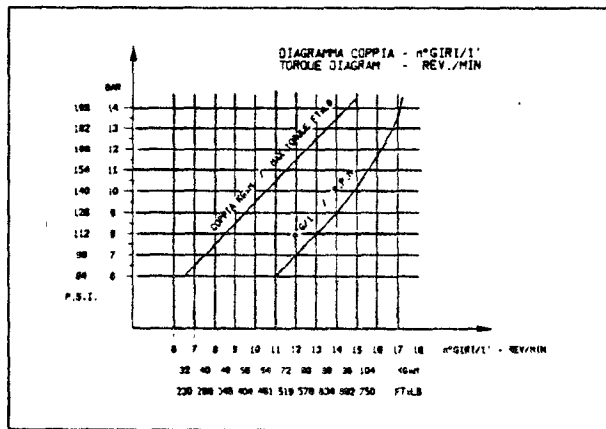

Fig.2

DIMENSIONS OF THE MACHINE:

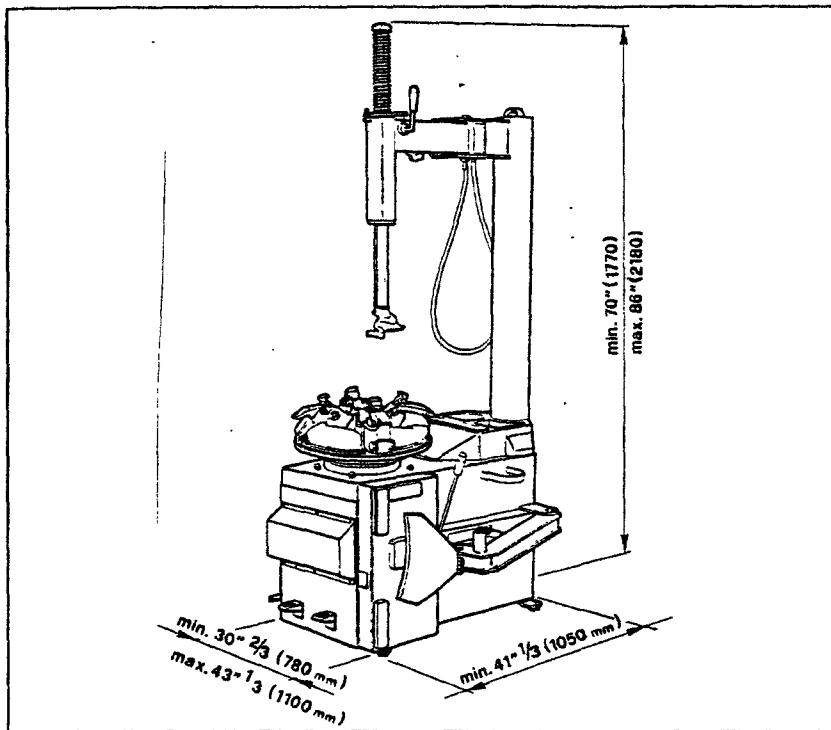

Fig.3

1.3 STANDARD ACCESSORIES

0001418 bead lifting tool

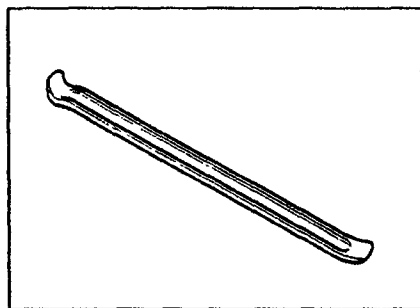

Fig.4

NOTE:
THE INFLATION GAUGE IS MOUNTED ON THE COLUMN.

1.4 OPTIONAL ACCESSORIES

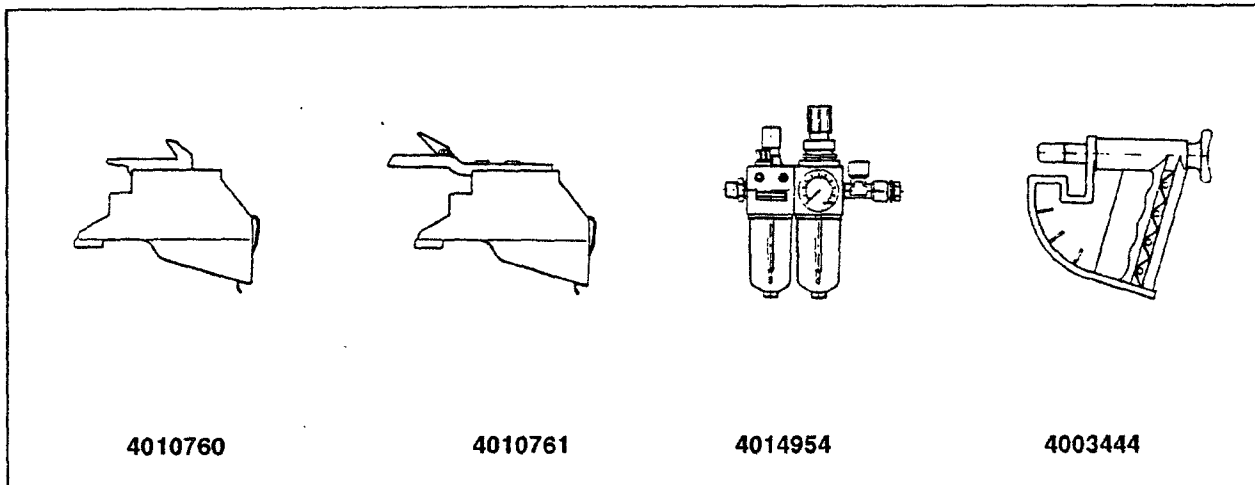

Fig.5

4010760 motorcycle adapter

4010761 8" adapter

4014954 air filter-lubricator and pressure regulator
with gauge

4003444 bead depressing tool

NOTE

INSTRUCTIONS FOR ASSEMBLING THE OPTIONAL ACCESSORIES ARE INCLUDED.

1.5 GENERAL PRECAUTIONS

A. DURING THE USE AND MAINTENANCE OF THE MACHINE IT IS MANDATORY TO COMPLY WITH ALL LAWS AND REGULATIONS FOR ACCIDENT PREVENTION.

B. BEFORE ANY MAINTENANCE OR REPAIRS ARE ACCOMPLISHED THE MACHINE MUST BE DISCONNECTED FROM THE AIR SUPPLY.

C. NEVER WEAR TIES, CHAINS OR OTHER LOOSE ARTICLES WHEN USING, MAINTAINING OR REPAIRING THE MACHINE. LONG HAIR IS ALSO DANGEROUS AND SHOULD BE KEPT UNDER A HAT. THE USER MUST WEAR PROPER SAFETY ATTIRE. IE; GLOVES, SAFETY SHOES AND GLASSES.

2.0 INSTALLATION

Install the machine in a covered and dry place. Operation temperature is +41/122 F (+5/50 C). The ACCU Model 3501 can work below 32 F, but some minor modifications are required: contact your ACCU distributor for detailed information.

A. Place all disassembled on the floor.

B. Attach the column #1 (Fig.6) to the cabinet #2 with the screws #4 and washers #3. The screws must be firmly tightened.

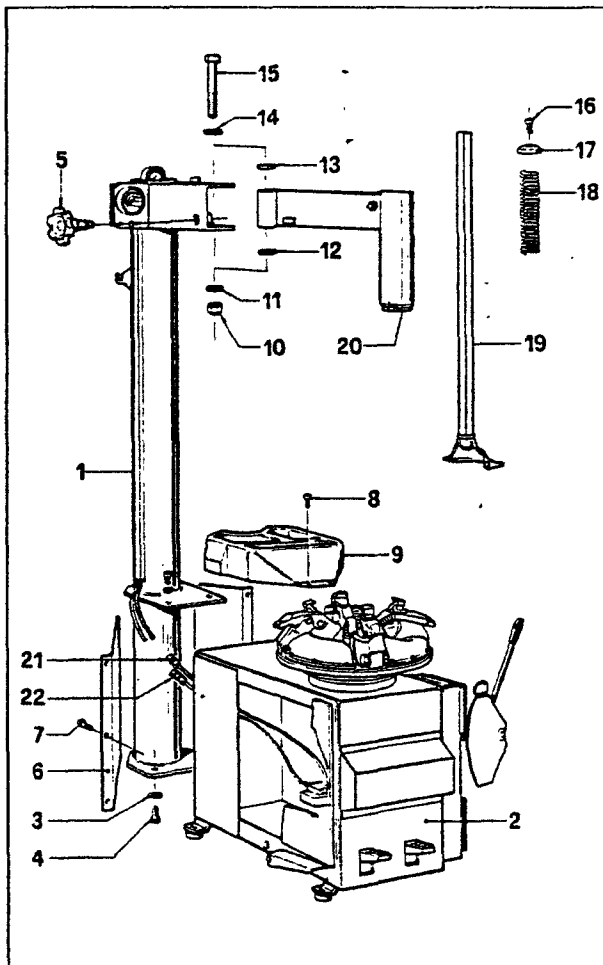

Fig.6

C. Attach the air hose #21 and the air hose #22.

D. Attach the adjustment knob #5 to the tower #1.

E. Attach the accessory tray #9 with the screws #8 and the panel #6 with the screws #7 to the cabinet #2.

F. Attach the swing arm #20 to the column #1 with the screw #15 and washer #12, #13, #14. Tighten nut #10 and washer #11.

IMPORTANT!

THE WASHERS #12, #13 (Fig.5) MUST BE PROPERLY IN PLACE.

G. Check the swing arm #20. If it is too tight, just release nut #10 (Fig.5), release the screw slightly #15 and tighten the nut #10 again. Repeat the check.

IMPORTANT!

THE ARM #20 SHOULD SWING FREELY BUT THERE SHOULD BE NO PLAY UP AND DOWN.

H. Attach the vertical slide #19 to the swing arm #20 with the spring #18, plug #17 and screw #16.

I. Mount the bead breaker arm #1 (Fig.6/a) on the cabinet, with the pin #7 and washers #6. Lock the pin #7 with the cotter pins #8.

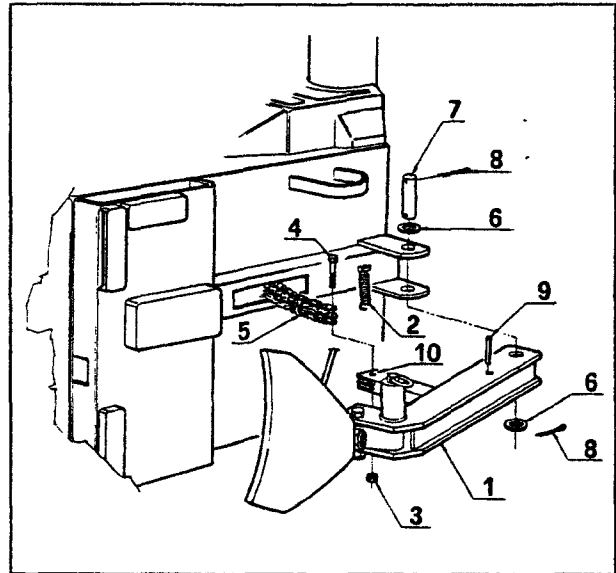

Fig.6/a

L. Connect the chain #5 to the bead breaker arm #1 with the screw #4 and lock the nut #3.

IMPORTANT!

DO NOT OVERTIGHTEN THE NUT #3.

M. Hook the spring #2 to the cabinet and secure it to the bead breaker arm #1 with the roll pin #9.

2.1 AIR INSTALLATION

WARNING!

THE AIR INSTALLATION MUST BE PERFORMED BY LICENSED PERSONNEL ONLY.

WARNING!

EXCESSIVE AIR PRESSURE CAN RESULT IN SERIOUS INJURY TO PERSONNEL AND DAMAGE TO THE MACHINE.

Ensure that the air pressure is within the limits required. If the pressure exceeds 175 psi (12 bar) it is mandatory to install a pressure regulator to the incoming air supply (OPTION #4014954).

This device is also suggested when working with motorcycle wheels.

If the air pressure is lower than the minimum requirement of 110 psi (8 bar) the clamping force, the torque of the turntable, and the bead breaker force may be insufficient for changing all tires.

It is also suggested that the air supply be equipped with a water separator, to reduce the water quantity of the incoming air.

After checking all the above proceed as follows:

A. Connect the machine to the air supply (rated at the maximum pressure of 175 psi) by a rubber hose having an internal diameter of no less than 1/4" (6 mm).

WARNING!

BEFORE CONNECTING THE MACHINE TO THE AIR SUPPLY BE SURE ALL PERSONNEL ARE CLEAR OF THE MACHINE AND THAT NOTHING IS LEFT ON THE TURNTABLE AREA (TOOLS, ETC.).

B. In case any of the optional accessories are required, please refer to the mounting instructions included with the accessories.

C. If an air lubricator is installed, ensure that it works properly.

Observe instructions given in @ 6.0.J.

3.0 CONTROLS

Before operating the machine, take the time to familiarize yourself with the operation and function of all the controls.

A. Press down and release the left pedal (#1 Fig.7) and the rim clamps will move inward.

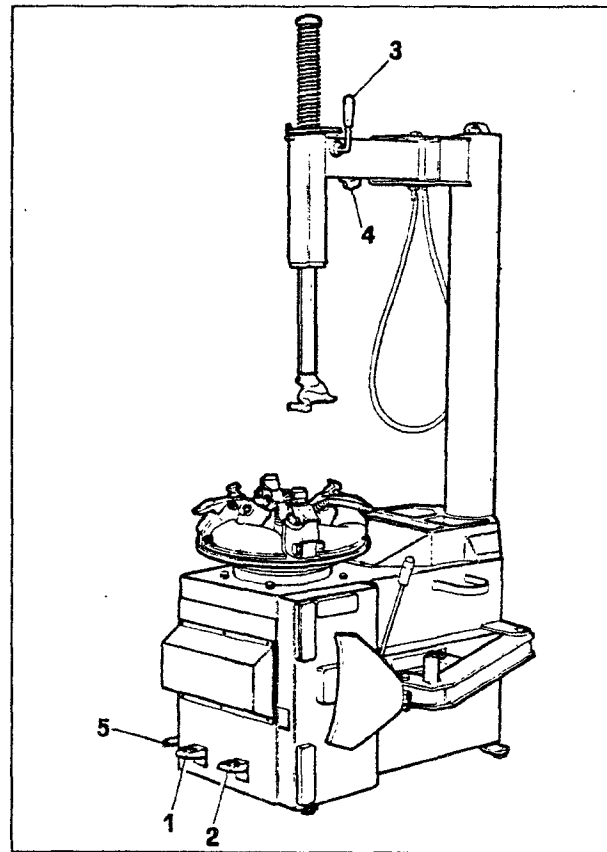

Fig.7.

Press it again and the clamps will move outward. By pressing the pedal part way down and releasing it, the rim clamps may be stopped in any position.

B. Open the bead breaker arm.

Press down and hold, the right pedal (#2 Fig.7) and the bead breaker arm will move towards the machine.

Release the pedal: and the bead breaker arm can be pulled away from the machine and tire.

C. Close the bead breaker arm. Press down and hold, the right pedal (#2 Fig.7) and the turntable turns clockwise.

Release the pedal and the turntable is free to turn both ways by hand.

NOTICE:

THE RIGHT PEDAL WILL ROTATE THE TURN-TABLE WHEN THE BEAD BREAKER ARM IS CLOSED AND WILL OPERATE THE BEAD BREAKER MECHANISM WHEN THE BEAD BREAKER ARM IS OPEN.

COUNTER-CLOCKWISE ROTATION OF TURN-TABLE CAN BE PROHIBITED (E.G. FOR MANUAL ROTATION OF THE TIRE ON THE RIM): PUSH THE RIGHT PEDAL DOWN AND CONTINUE TO HOLD IT ALSO AFTER THE TURNTABLE HAS COMPLETED ONE REVOLUTION AND COME TO A STOP, OR PUSH RIGHT PEDAL TO HALF STROKE.

D. Move the lock handle (#3 Fig.7) up to lock the vertical slide, pull it down to release it.

E. Use the adjustment knob (#4 Fig.7) to position the mount/demount head for different diameter wheels.

WARNING!

WATCH YOUR FINGERS AND LEGS!

F. Push inflation pedal (#5 Fig.1 left side of the machine) half stroke: air flows from hose.

G. Press the air inflator full stroke (#5 Fig.1): and a large volume of air will flow from the inflator jets of the clamps to seat the beads of tubeless tires. Air will simultaneously flowing from inflation hose.

H. Deflation of the tire is possible by pushing exhaust button.

ATTENTION!

WHEN OPERATING THE BEAD SEATER IT IS MANDATORY TO WEAR SAFETY GLASSES TO PROTECT EYES.

4.0 MOUNTING AND DEMOUNTING TIPS

IMPORTANT!

BEFORE MOUNTING A TIRE ON A RIM, PAY ATTENTION TO THE FOLLOWING:

A. THE RIM MUST BE CLEAN AND IN GOOD CONDITION: IF NECESSARY CLEAN AND PAINT IT AFTER REMOVING ALL WHEEL-WEIGHTS, TO INCLUDE 'TAPE WEIGHTS' INSIDE THE RIM.

B. THE TIRE MUST BE CLEAN AND DRY, WITHOUT ANY DAMAGE TO THE BEAD.

C. REPLACE THE RUBBER VALVE STEM WITH A NEW ONE OR REPLACE THE 'O'RING IF THE VALVE STEM IS MADE OF METAL.

D. IF THE TIRE REQUIRES A TUBE, MAKE SURE THE TUBE IS DRY AND IN GOOD CONDITION.

E. LUBRICATION IS NECESSARY TO MOUNT THE TIRE CORRECTLY AND GET A PROPER CENTERING. BE USE APPROVED LUBRICANT ONLY.

F. MAKE SURE THE TIRE IS THE CORRECT SIZE FOR THE RIM.

4.1 DEMOUNTING TUBELESS TIRES FROM ONE-PIECE RIMS

A. Remove the valve or core and deflate the tire (Fig.8). Remove all wheel weights.

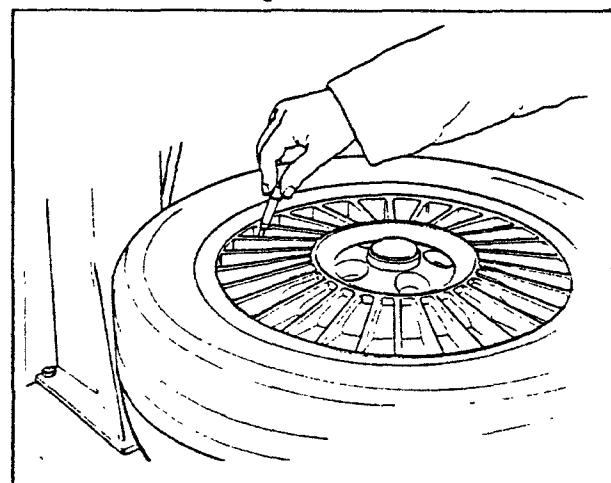

Fig.8

B. Break both beads.

Pay extra attention during this operation as it is easy to mistakenly keep your foot on the bead breaking pedal too long.

This could result in immediate bead damage. (Fig.9).

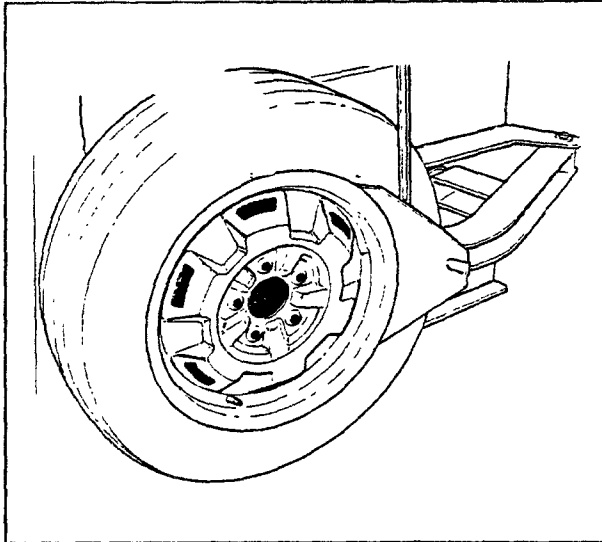

Fig.9

WARNING!

ON CHEVROLET CORVETTE WHEELS WITH THE OPTIONAL LOW PRESSURE SENSOR INSTALLED, BREAK THE BEAD AT 90 DEGREES OFFSET FROM THE VALVE STEM. DAMAGE TO THE WHEEL WILL RESULT IF THE BEAD IS BROKEN AT ANY OTHER POINT ON THE RIM.

C. Set the rim clamps to the proper position retract clamps to clamp the wheel from the inside and expand clamps to clamp from the outside.

When clamping small wheels (14" or smaller) from the outside, set the clamps at a diameter nearly equal to the rim diameter, before placing the wheel on the clamps.

This will help avoid the possibility of pinching the tire.

NOTICE

TO MINIMIZE THE RISK OF SCRATCHING ALLOY RIMS, THESE SHOULD BE CLAMPED FROM THE OUTSIDE.

WARNING!

BE SURE TO USE ONLY APPROVED LUBRICANTS. DO NOT USE LUBRICANTS THAT CONTAIN WATER, PETROLEUM PRODUCTS/HYDROCARBONS, OR SILICONE.

D. Lubricate both bead seat areas liberally.

Place the wheel **WITH DROP THE CENTER UP** (Fig. 10) on the turntable and clamp in position. Hold the tire and wheel down while clamping.

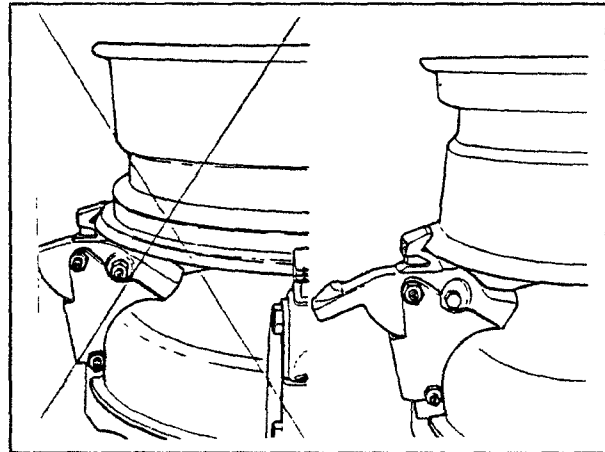

Fig.10

E. Position the mount/demount head in contact with rim edge and lock it into place. The tool automatically moves away from the rim edge vertically. Turn the adjustment knob until the mount/demount head clears the rim flange about 1/16" (2 mm): this is necessary to avoid any rim damage (Fig.11).

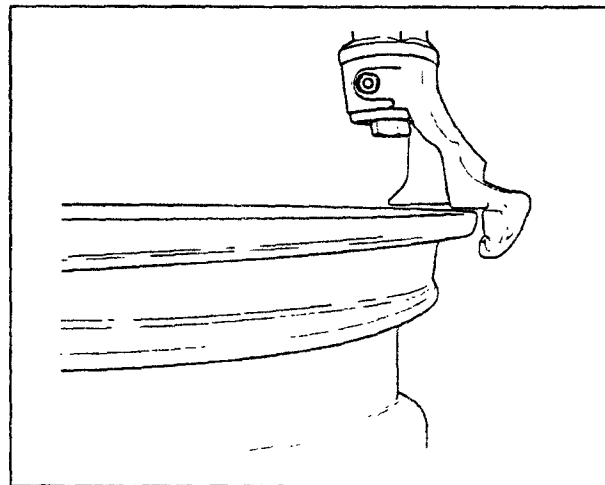

Fig.11

NOTE:

THE ROLLER INSIDE THE MOUNT/DEMOUNT TOOL MAY BE REPLACED BY A PLASTIC INSERT. REPLACEMENT IS SUGGESTED FOR OPERATORS MAINLY WORKING ON LIGHT ALLOY RIMS. EVERY MACHINE IS EQUIPPED WITH SEVERAL PLASTIC INSERTS (INSIDE STANDARD EQUIPMENT BOX). THE PLASTIC INSERTS WILL HELP AVOID DAMAGE FROM ACCIDENTS CONTACT BETWEEN THE TOOL AND THE RIM. THE PLASTIC INSERTS MUST BE PERIODICALLY REPLACED.

NOTE:

ONCE THE MOUNT/DEMOUNT HEAD IS POSITIONED PROPERLY, MATCHING WHEELS MAY BE CHANGED WITHOUT HAVING TO RESET THE HEAD.

F. Insert the bead lifting tool under the bead and over the support of the mount/demount head. Lift the bead onto the mounting finger.

To make this operation easier, insure that the bead of the tire, directly across from the mount/demount head, is in the drop center of the wheel. Push the tire into the drop center with your hand or bead depressor tool if necessary.

If desired, the bead lifting tool can be removed after lifting the bead onto the finger (Fig.12).

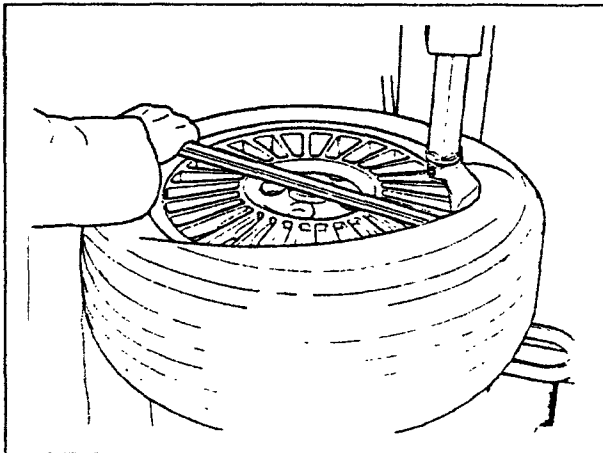

Fig.12

G. Rotate the turntable clockwise and at the same time push down on the tire sidewall to move the bead into the drop center of the rim (fig.13).

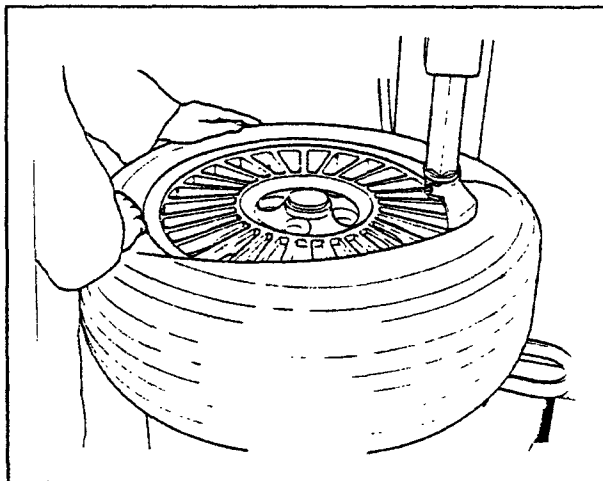

Fig.13

H. Repeat the process for removing the lower bead. This time, lift the bead opposite to the mount/demount head to keep it in the drop center (Fig.14). Move the swing arm aside and remove the tire.

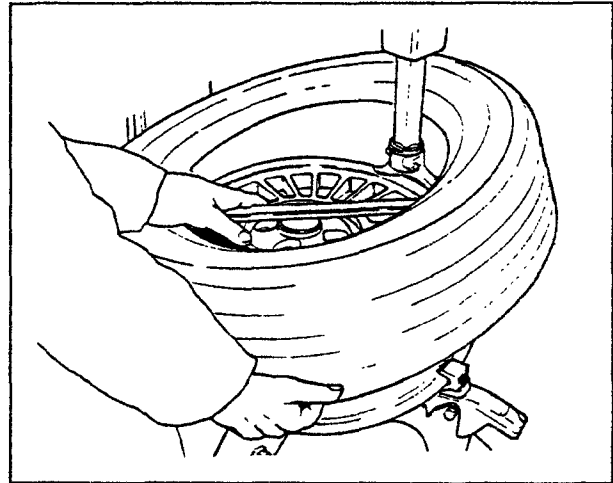

Fig.14

4.2 MOUNTING TUBELESS TIRES ONTO ONE-PIECE RIMS

A. Lubricate the entire rim surface (Fig.15).

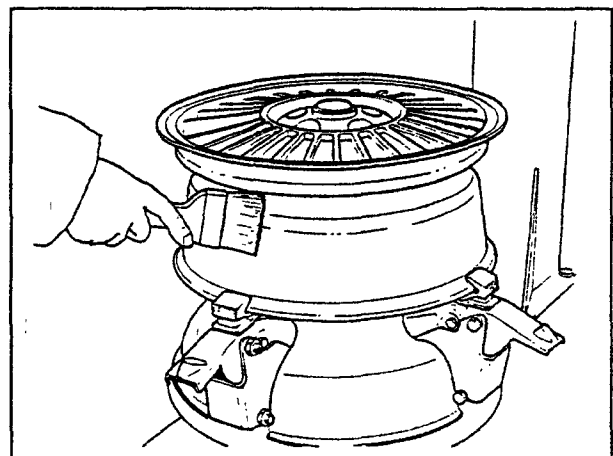

Fig.15

Liberally lubricate both beads of the tire (fig.16).

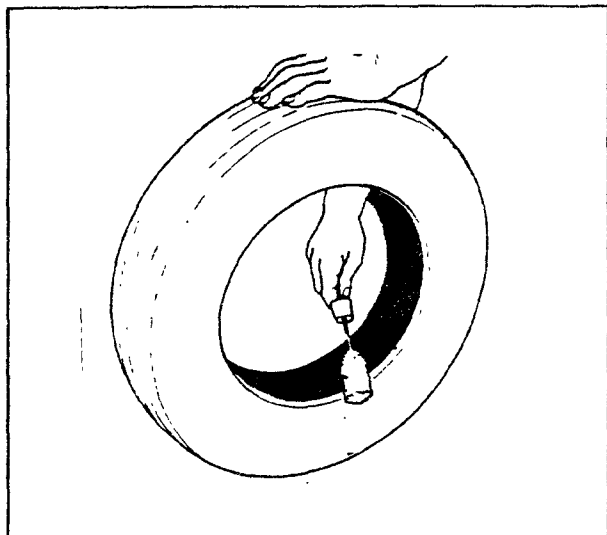

Fig. 16

WARNING!

THESE LUBRICATION OPERATIONS ARE NECESSARY TO MOUNT THE TIRE CORRECTLY AND GET PROPER CENTERING ON THE RIM. BE SURE YOU ARE USING APPROVED LUBRICANT ONLY.

WARNING!

SOME TIRES HAVE A COLOR DOT THAT MUST BE KEPT ON THE OUTSIDE OF THE WHEEL. IF THIS IS THE CASE BE SURE TO ATTAIN PROPER ALIGNMENT.

B. Lock the rim on the chuck and rotate it to have the valve at the 2 o'clock position.

Place the tire to be mounted on the rim. Swing the mounting arm forward so that the mount-demount tool is in the working position.

Engage the lower bead OVER the mounting wing and UNDER the mounting finger of the mounting tool.

Turn the wheel clockwise and push the tire down into the drop center, opposite to the mount/demount head (fig. 17).

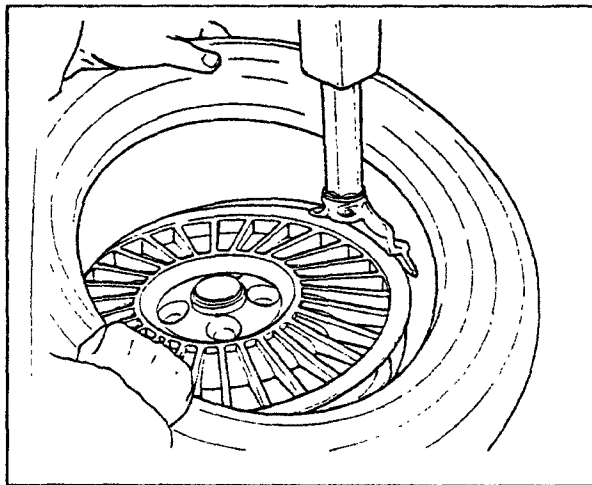

Fig. 17

C. Mount the upper bead following the directions in section B. With low profile tires the bead depressor tool (OPTION #4003444) Fig. 18 can help to ease the mounting of the top bead.

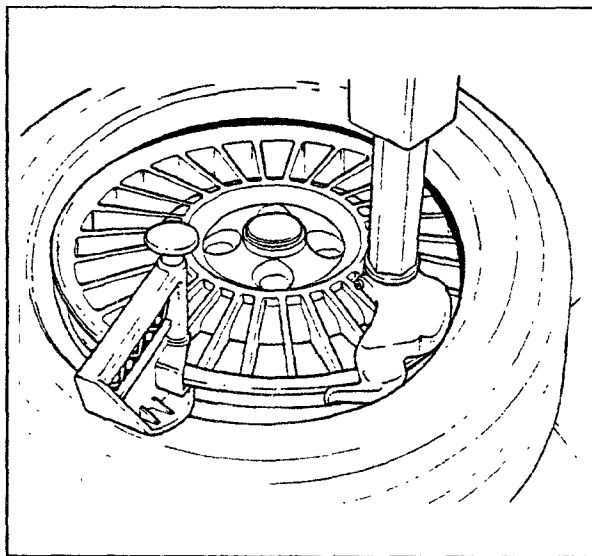

Fig. 18

4.3 INFLATING TUBELESS TIRES

A. Make sure that both beads are properly lubricated. Inflate the tire according to manufacturers recommendations.

WARNING!

BEAD SEATING IS THE MOST DANGEROUS PART OF MOUNTING A TIRE. IT IS POSSIBLE TO MOUNT TIRES THAT ARE 1/2" SMALLER IN DIAMETER THAN THE RIM THAT THEY ARE MOUNTED ON. WHILE THESE BEADS WILL SEAL, IT IS IMPOSSIBLE TO GET THEM TO SEAT IN THEIR PROPER POSITION. EXPLOSION OF A TIRE MAY CAUSE SEVERE INJURY OR DEATH.

WARNING!

NEVER EXCEED THE MAXIMUM PRESSURE ALLOWED BY THE TIRE MANUFACTURER.

THE RIM MUST BE UNCLAMPED WHEN INFLATING. BUT ONLY AFTER THE BEADS HAVE BEEN SEATED.

THE OPERATOR MUST STAND CLEAR FROM THE WHEEL WHEN INFLATING, AND PRESSURE MUST BE MONITORED FREQUENTLY TO AVOID EXCESSIVE INFLATION.

BEFORE INFLATING A TIRE CHECK THE CONDITION OF THE TIRE AND THE RIM.

Due to unusual configurations or the stacking of tires the inflation process is sometimes difficult.

To assist with this problem the ACCU Model 3501 is equipped with bead seater jets incorporated into the table top.

To utilize the bead seater proceed as follows:

A. If possible lock the wheel from the inside. Outside locking reduces efficiency.

B. Connect the inflation hose to the valve stem.

C. Lift the tire with both hands so that the upper bead is sealed to the rim edge (Fig.19).



Fig.19

D. Press the inflation pedal down swiftly (#17 Fig.1). The top bead is already sealed by the lifting motion. Therefore, the air from the bead seater jets will impact the top sidewall and rebound into the bottom sidewall driving it into place and creating a seal.

ATTENTION!

WHEN OPERATING THE BEAD SEATER WEAR APPROPRIATE SAFETY ATTIRE TO AVOID INJURY TO BODY OR EYES.

E. Complete inflation as described at @4.3.A.

5.0 DEMOUNTING TUBE-TYPE TIRES ON ONE-PIECE RIMS

A. For breaking the bead operate as described for the tubeless tires in @4.1.A to @4.1.F.
 In this case the valve is part of the tube.

WARNING!
 BE CAREFUL NOT TO DAMAGE THE TUBE DURING THE BEAD-BREAKING OPERATION. THE VALVE SHOULD BE OPPOSITE TO THE BLADE OF THE BEAD BREAKER.

B. To demount the first bead, place the valve at the 2 o'clock position.

WARNING!
 DO NOT CATCH THE TUBE WITH THE BEAD LIFTING TOOL, WHEN LIFTING THE BEAD ONTO THE MOUNTING FINGER.

After demounting the first bead remove the tube before demounting the second bead, as described in @4.1.G.

5.1 MOUNTING TUBE-TYPE TIRES ON ONE-PIECE RIMS

A. Do as described in @4.2.A.
 Do NOT lubricate the tube. Talc can be used to assist with tire positioning.

B. Confirm that the tube is designed for tires (fig.20).

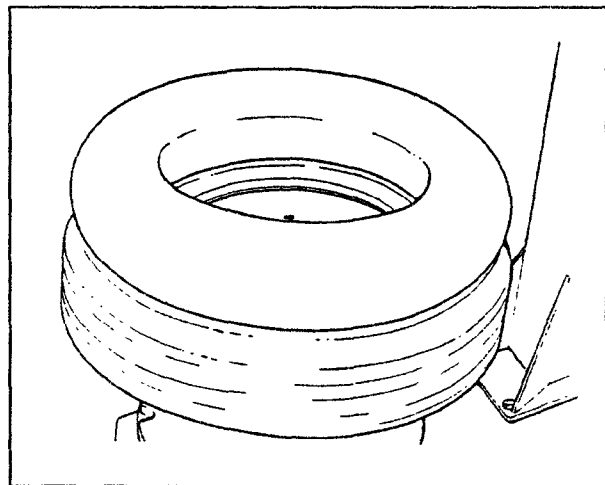

Fig.20

C. Inflate the tube slightly: if held with the index finger it should bend a little (Fig.21).

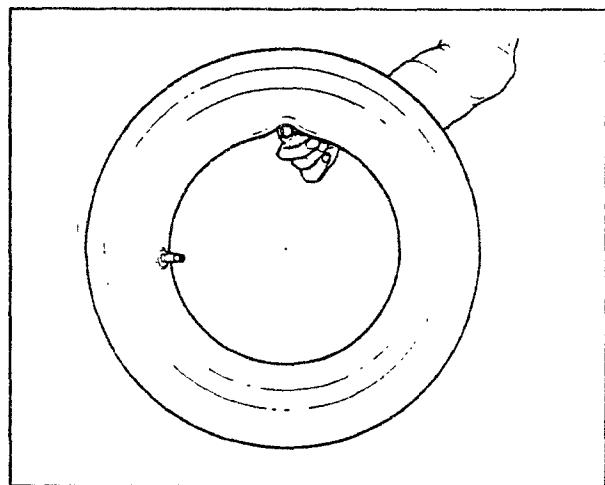

Fig.21

D. Mount the first bead as described in @4.2.B.
 Put the tube inside the tire and hang the valve with the clip of the inflating hose (fig.22).
 Mount the top bead following the directions above.

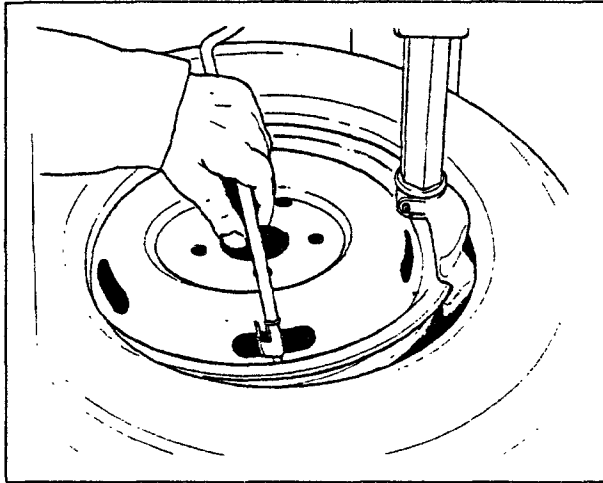

Fig.22

6.0 MOUNTING AND DEMOUNTING MOTORCYCLE TIRES

To mount and demount motorcycle tires it is necessary to utilize the optional motorcycle adaptors (4 pieces #4010760).

The bead-breaking, mounting and demounting technique is the same as per the car, tubeless or tube-type tires.

WARNING!

**MOTORCYCLE RIMS MUST ALWAYS BE CLAMPED FROM THE OUTSIDE.
 AIR PRESSURE MUST NOT EXCEED 110 PSI (8 BAR) WHEN CLAMPING MOTORCYCLE RIMS.
 IF NECESSARY INSTALL A PRESSURE REGULATING DEVICE (OPTIONAL #4014954).**

5.2 INFLATING TUBE-TYPE TIRES

A. To inflate the tire unlock the rim and start inflating while pressing the valve towards the inside (this is necessary to avoid air pockets forming between the tube and the tire) (fig.23).

Ensure that the tire is correctly centered on the rim and complete inflation as described in @4.3.A.

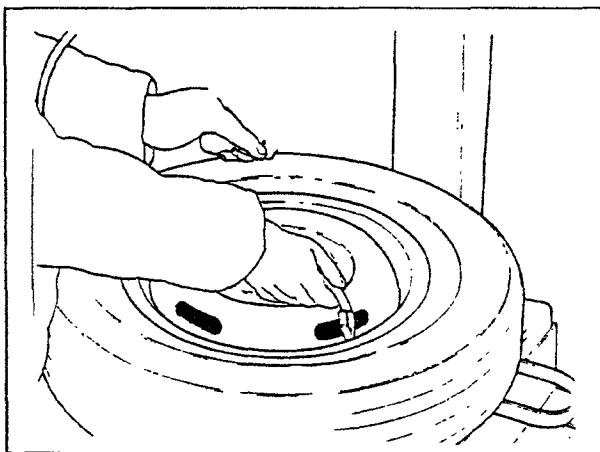

Fig.23

7.0 MAINTENANCE

WARNING!

BEFORE STARTING ANY MAINTENANCE OPERATION ENSURE THAT THE MACHINE IS DISCONNECTED FROM THE AIR SUPPLY.

A. Periodically clean the vertical hexagonal rod with nonflammable liquid detergent. After this, immediately lubricate with oil (fig.24).

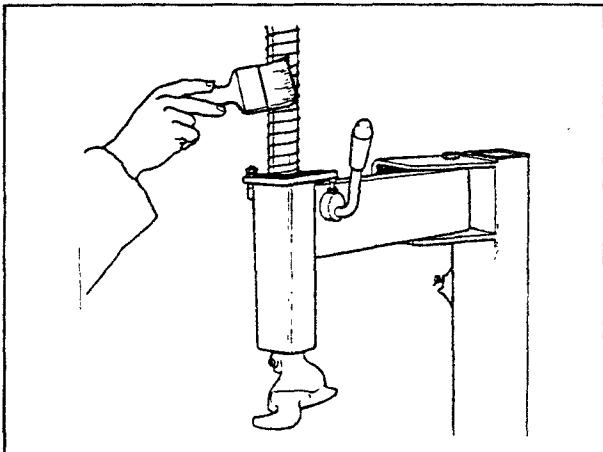

Fig.24

B. Periodically clean all moving metal parts and lubricate with oil.

C. Clean the teeth of the clamps with a wire brush, check the plastic rim protector and replace it if worn (Fig.25).

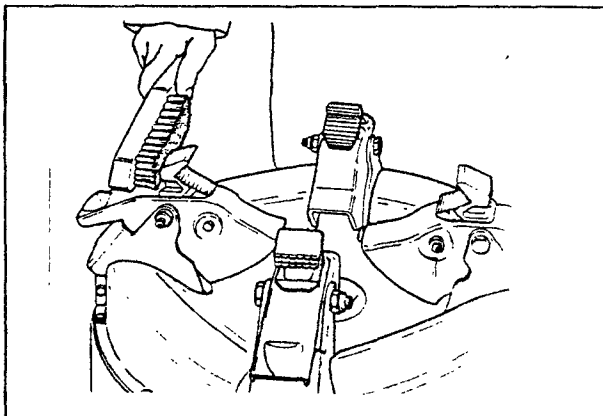

Fig.25

D. Periodically replace the plastic insert inside mount/demount tool.

E. Periodically wash all plastic parts with cold water and soap or window cleaner.

F. Lubricate rods of air cylinders with oil as needed.

G. Check the bead breaker pads. Replace if worn.

H. If the machine is equipped with an automatic air lubricator, check the oil level weekly. When adding oil to the lubricator, disconnect the air supply first, remove the fill screw 'A', and add oil as needed. Make sure seals are in place when replacing the cap.

Drain water daily from water separator. Do this by pulling down the fitting 'B' (Fig.26).

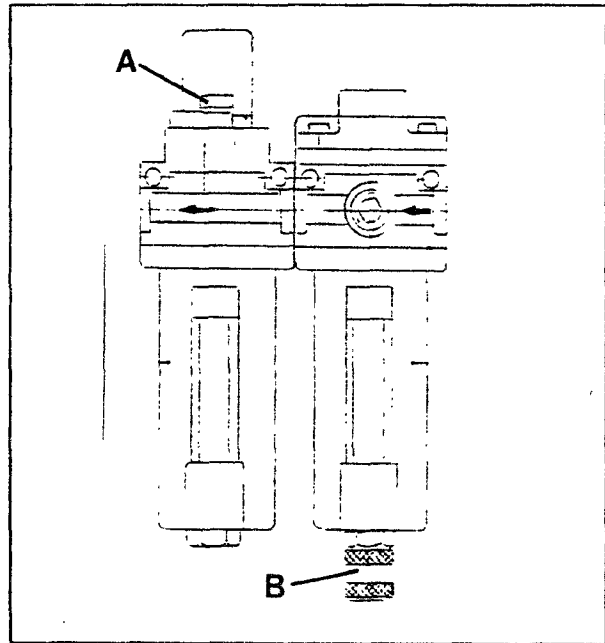

Fig.26

WARNING!

USE ONLY OILS FOR AIR DEVICES, DO NOT USE BRAKE FLUID OR OTHER NON-SUGGESTED LUBRICANTS.

Suggested oils for the filter/lubricator unit:

TAMOIL	:	WITHE MINERAL OIL 15
SHELL	:	ONDINA OIL 15
BP	:	ENERGOL WT 3
TOTAL	:	LOBELIA SB 15
ESSO	:	MARCOL 82

L. If the machine is not equipped with an automatic lubricator, perform the following:

- * Disconnect the machine from the air supply.
- * Open the lubrication cap and drop a small quantity of oil (2-3 cc) (Fig.27).
- * Close the oil cap and tighten firmly.
- * Connect the machine to the air supply and operate both the turntable clamping and bead breaker a several times.

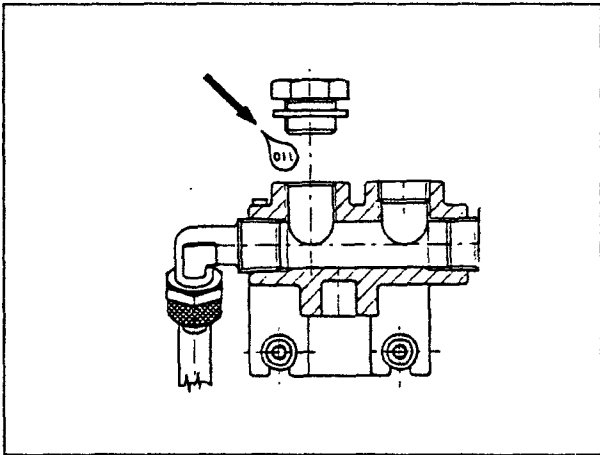

Fig.27

M. Drain water daily from the tank (Fig.28).

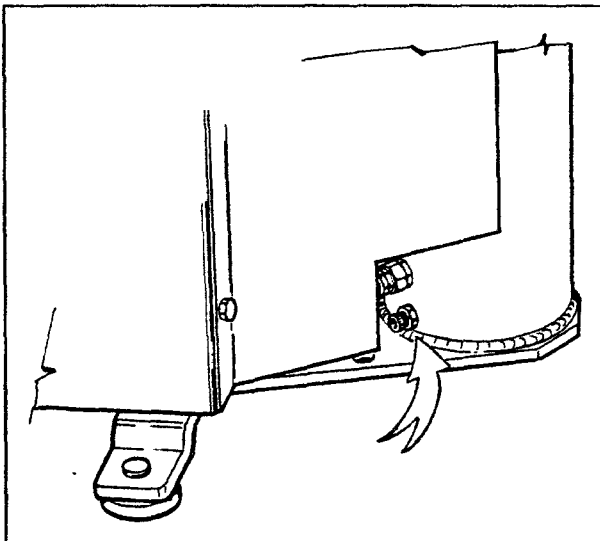

Fig.28

WARNING!

BE SURE THAT THE COMPRESSED AIR IS DISCONNECTED BEFORE REPLACING THE RUBBER PROTECTION. FAILURE TO DO SO MAY RESULT IN SERIOUS INJURY.

ALWAYS CHECK THE CONDITION OF THE RUBBER TURNTABLE PROTECTION: IF IT IS WORN OR DAMAGED, REPLACE IT WITH A CORRECT SPARE PART.

N. Periodically remove dirt and grease from the inside of the turntable. Remove the rubber protection before cleaning.

299

1 2 3 4 5 6

A

B

C

D

E

21

0015854

0014544

7024019

7117021

0015853

0001229

0014446

7021041

7020041

0001349

7207269

7020581

0011499

0009986

7024012

0001156

7021132

4015779

7023199

7021132

7024012

7105340

7020111

0011055

0002238

0001432

0010314

0014447

4014511

0014491

0011227

7105019

7021102

7021012

7020011

0014493

0011528

4015762

7204019

7110029

7020339

0011460

0001432

0010314

7202099

7021232

0009882

0009141

0008074

0001384

7117021

7021091

0014671

0013329

0015806

0009107

0009142

0007489

0009105

0009106

0008074

0001384

0009103

0001349

0009829

0006345

0015808

7020409

4014628

4009884

7102169

ACCU 3501

09/93

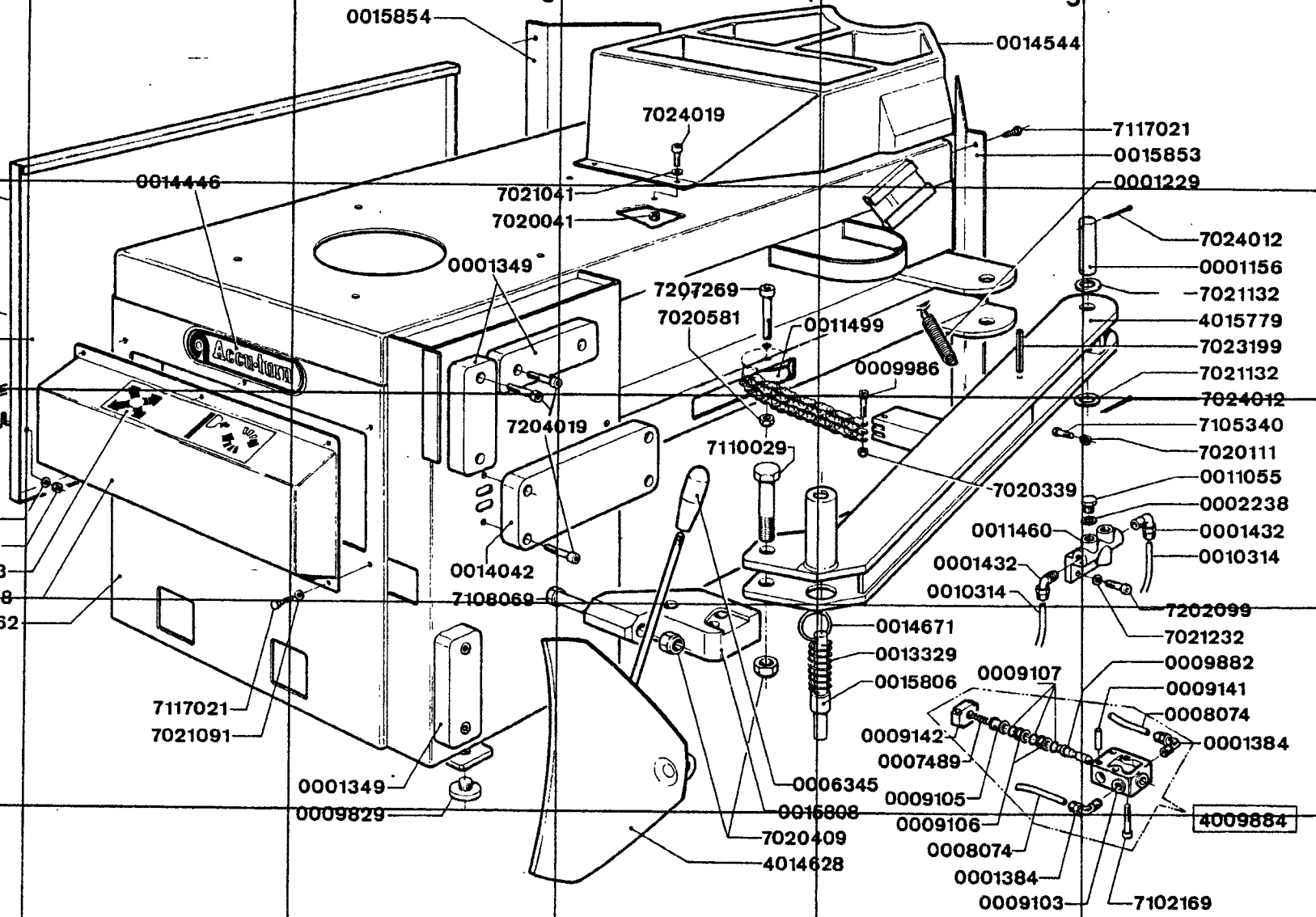

300

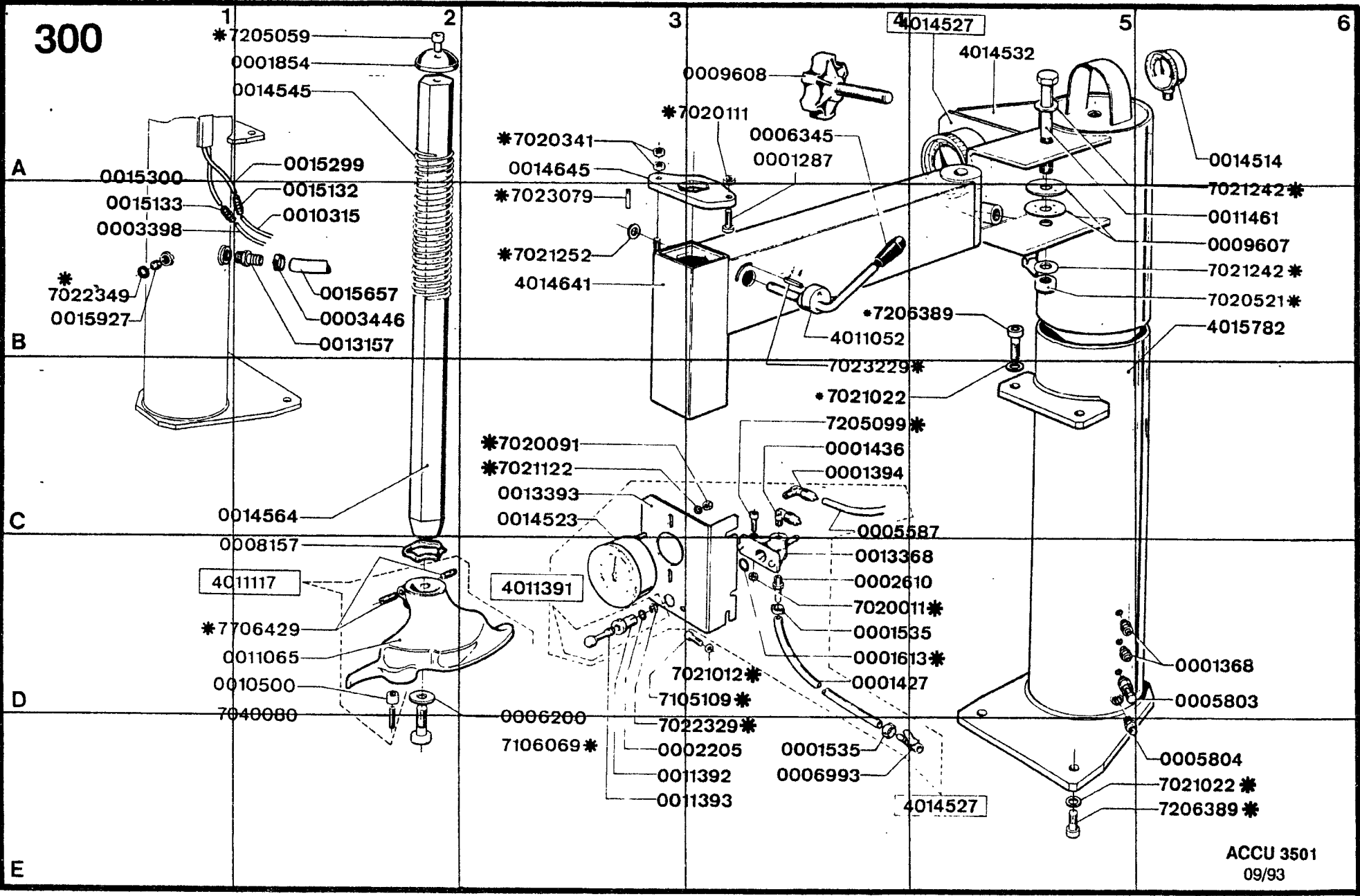

ACCU 3501
09/93

77

301

1

2

3

4

5

6

A

B

C

D

E

4014921

0001402
0001203
0008751

0001203
0008752
0001404

0001368
7021082 *
00010241
0001775

*7021119

0013364

7020479 *

0003445

0015656
0013155

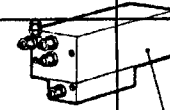

4014939

0002488
0001255
*7020339
0005643

*7104189
0001368

7023059 *

0014920
0005626 *7021182
0005643 *7204019
4005635

0001943
0010315
0001368
0010315
0001943
0009509
0005349

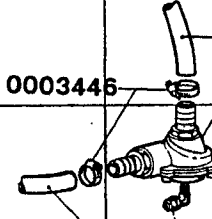

0001384
0015657

4009611

4013082
*7023119
*7105029
*7021011
*7020111
4013078

7020111 *

0002486
*7020339

0002349
*7020339

0009977
*7020041

*7104049

0009587

*7020011

*7021039

0009613

*7105469

*7020339

0011336

0010674
0010673

0010674

0004751 *

0009533

0009494

7104289 *

7021012 *

7105019 *

7021042 *

*7020041

0009587

*7104049

*7020011

*7021039

0009613

*7105469

0008074
0010315
0010314

0001368
0005589
0001404

0009510

0005349

0010674

4009612

0010673

0011336

7104289 *

7021042 *

0009577

7021012 *

7105019 *

7020339

23

ACCU 3501
09/93

302

1

2

3

4

5

6

A

B

C

D

E

24

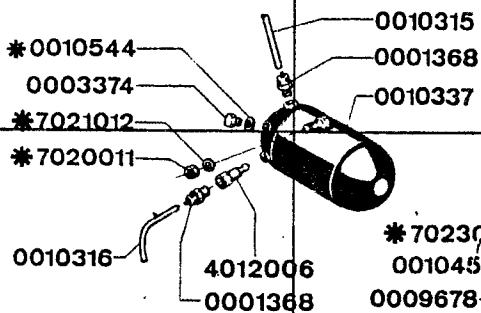

0004740

*7023079

0010458

0009678

0010460

0010042

0009906

0009936

0009680

0010316

0009905

*7107189

*7107219

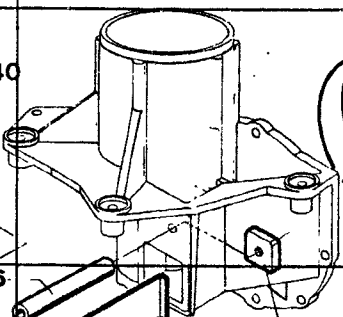

*7020011

0011796

*7020011

0009715

0009985

*7020339

0012363

4015868

*7020581

0010312

*7020441

0009719

4010324

0009652*

0009720

0009651*

0009681

0009649

0015857

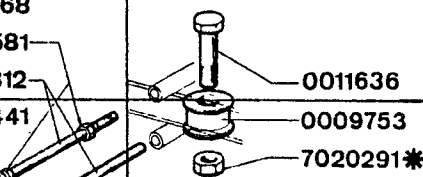

4010504

7203079*

0010506

0010507

0010505

0010374

0009676

0003638

0001432

0005589

ACCU 3390

ACCU 3501

09/93

276

1

2

3

4

5

6

A

B

C

D

E

25

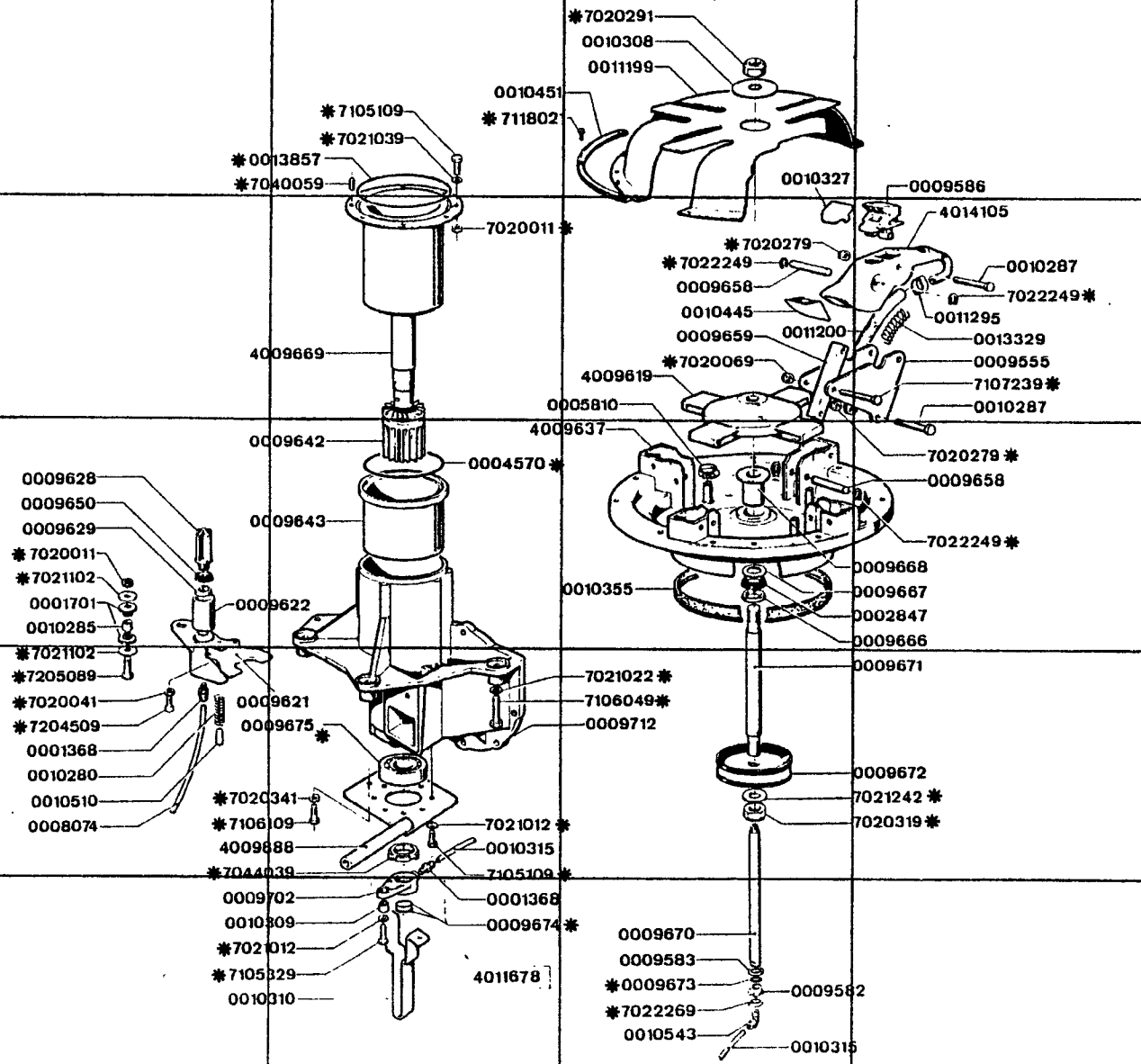

ACCU 3501
 ACCU 3390
 02/93