



TABLE OF CONTENTS  
MODEL 8750/8800 OCL

Warranty Registration .....	2
Warranty .....	3
Vehicle Preparation .....	4
Attaching the Lathe using Universal Plates (8750) .....	5
Threaded Plates (RED) .....	6
Unthreaded Plates (BLUE) .....	7
Attaching the Lathe using Universal Slide Mounts (8800)	
Threaded Slides (RED) .....	8
Unthreaded Slides (BLUE) .....	10
Installing the Auxiliary Drive Unit .....	12
Lathe Operation .....	14
Trouble Shooting .....	16
Parts Breakdown .....	18
Electrical Diagram .....	29
Maintenance .....	30
Specifications .....	31

**WARRANTY REGISTRATION**

Congratulations on your selection of the world's finest, most accurate, on-car disc brake lathe. Properly maintained and cared for, your ACCU-TURN on-car-lathe and accessories will give you years of trouble-free service.

Registration of your warranty is recommended for ease of service, so for complete protection, complete and mail the warranty registration card immediately.

When ordering parts, please refer to the serial numbers on the lathe or the drive unit.

Please record the serial numbers of the lathe and drive unit for reference:

Lathe Serial Number: OCL-\_\_\_\_\_

Drive Unit Serial Number \_\_\_\_\_

Purchase date: \_\_\_\_\_

## VEHICLE PREPARATION

1. Raise the vehicle to the preferred height.
2. Remove the wheel and the brake caliper. Suspend the caliper out of the way using the provided "S" hook.
3. Check the rotor thickness to determine if it can be machined safely.
4. Secure the rotor on to the hub using the vehicle lug nuts and the provided concave-receiving washers (#871902). Torque the nuts to the manufacturer's specifications. (See page 13 for installing drive yoke)
5. Check the wheel bearings for excessive play or roughness. Adjust or replace as necessary.  
**REMEMBER IT IS IMPOSSIBLE TO MACHINE ROTORS PROPERLY ON LOOSE OR DAMAGED BEARINGS.**
6. Install the silencer band on the rotor.
7. Examine the vehicle's caliper lugs for rust or debris. Clean with a wirebrush.

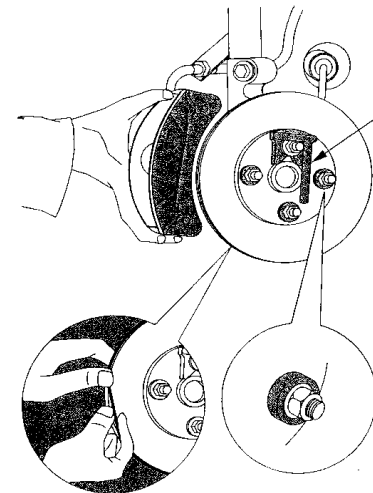

## ATTACHING THE LATHE USING UNIVERSAL PLATES

*8750 ONLY*

In the lathe storage box are two types of universal connecting plates, threaded (red) and unthreaded (blue). When attaching the plates to a vehicle that has unthreaded caliper lugs, use the red threaded plates on the outboard side of the lug. Conversely, when the vehicle has threaded caliper lugs, use the blue unthreaded plates on the inboard side of the lugs. With either type of plate, attach the end of the plate having the single hole to the caliper lug. The lathe will mount to the end of the plate that has three holes. In the majority of set ups the middle hole is recommended.

After selecting the proper plates, attach the plates to the lathe and **hand tightened only**. Hold the lathe up to the lug to determine if any spacer is required to properly center the rotor within the lathe body. Remember to retract the tool slides to prevent tool bit damage. Rotor centering is imperative!

Once the lathe centering is determined, bolt the lathe to the caliper lugs and again, only **hand tighten**. The lathe may now be pivoted in to position so that the bit will travel through the imaginary centerline of the axle. Once positioned, all mounting bolts should be securely tightened.

You are now ready to install the auxiliary drive unit as described on page 8.

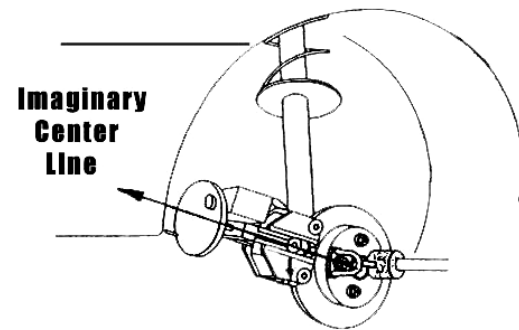

**8750 THREADED UNIVERSAL MOUNTING PLATE**  
**APPLICATION**

#877019, RED

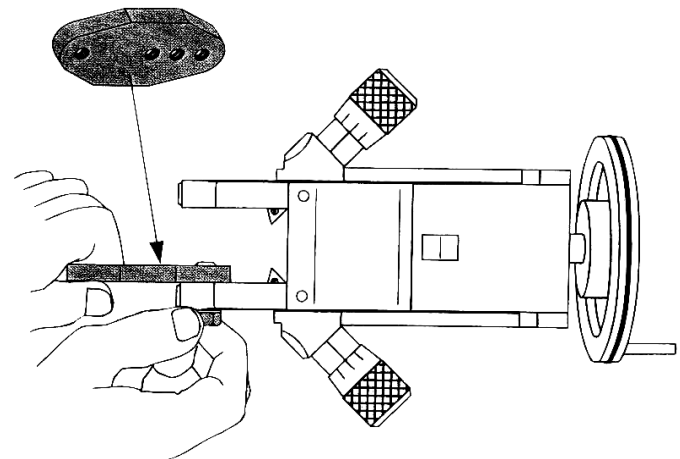
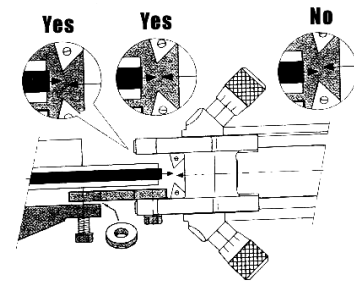
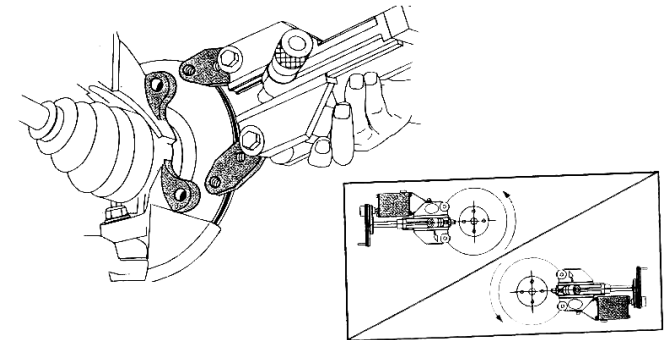

**8750 UNTHREADED UNIVERSAL MOUNTING PLATE**  
**APPLICATION**

#877020, BLUE

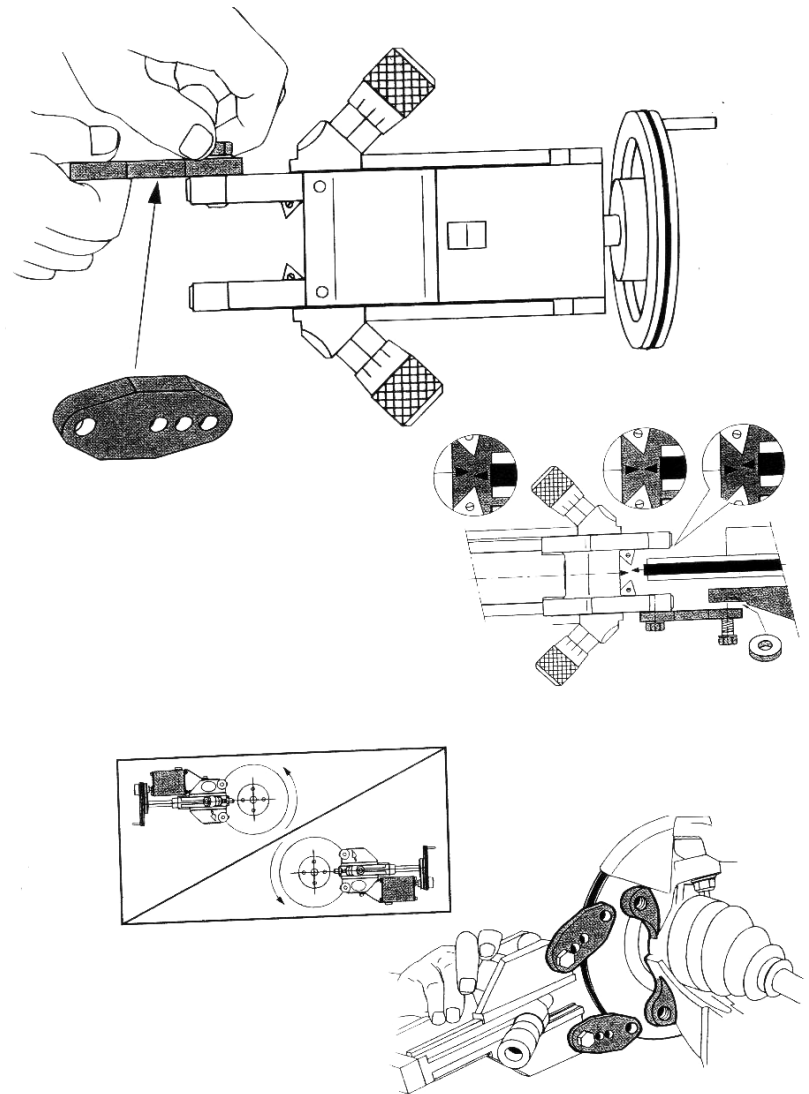

## MOUNTING INSTRUCTION USM 2002 FOR DISC ALIGNER DL-8700/02

### RED MOUNTING SYSTEM / Caliper ears without thread

**1.**

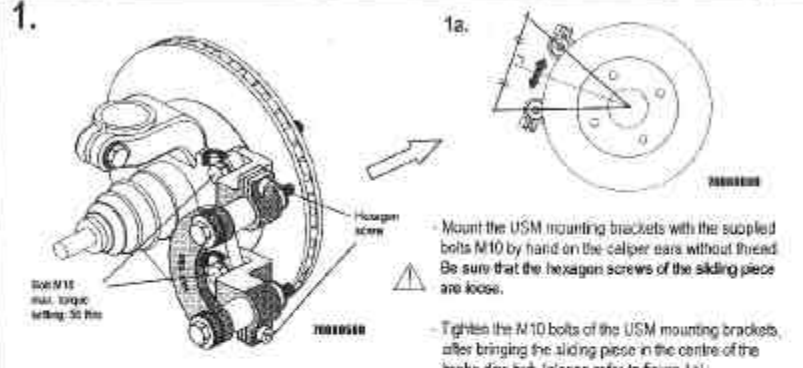

1a.

- Mount the USM mounting brackets with the supplied bolts M10 by hand on the caliper ears without thread. Be sure that the hexagon screws of the sliding piece are loose.
- Tighten the M10 bolts of the USM mounting brackets, after bringing the sliding piece in the centre of the brake disc hub (please refer to figure 1a).

**2.**

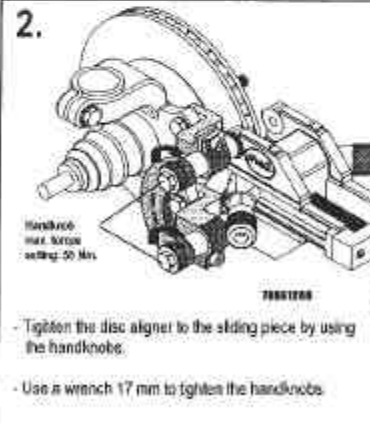

- Tighten the disc aligner to the sliding piece by using the handknobs.
- Use a wrench 17 mm to tighten the handknobs.

**3.**

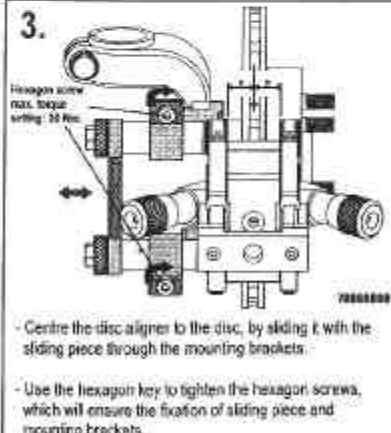

- Centre the disc aligner to the disc, by sliding it with the sliding piece through the mounting brackets.
- Use the hexagon key to tighten the hexagon screws, which will ensure the fixation of sliding piece and mounting brackets.

**PARTS LIST USM 2002-R1**

876069

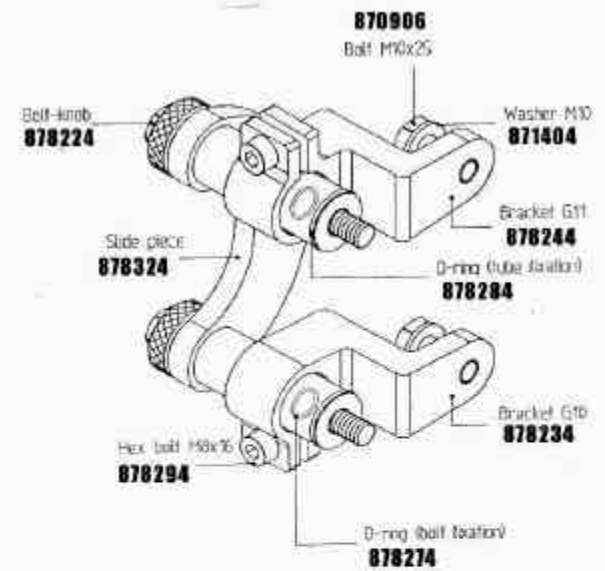

Hex-look/ball driver 6 mm  
**878314**

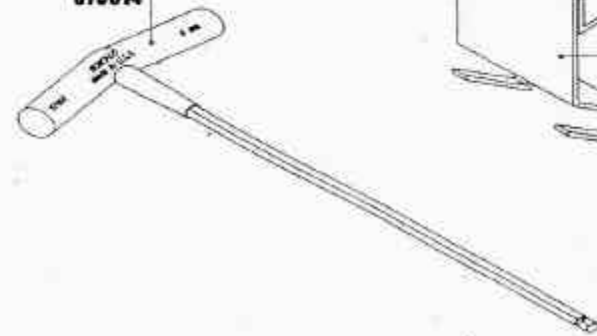

Storage bracket  
**878304**

**MOUNTING INSTRUCTION USM 2002**  
**FOR DISC ALIGNER DL-8700/02**

**BLUE MOUNTING SYSTEM / Caliper ears with thread**

**1.**

**1a.**

- Mount the USM mounting brackets with the original caliper bolts by hand on the caliper ears with thread. If necessary, a spacer can be used to achieve the correct bolt length. Be sure that the hexagon screws of the sliding piece are loose.
- Tighten the original caliper bolts of the USM mounting brackets, after bringing the sliding piece in the centre of the brake disc hub (please refer to figure 1a)

**2.**

**Handknobs max. torque setting: 50 Nm.**

- Tighten the disc aligner to the sliding piece by using the handknobs.
- Use a wrench 17 mm to tighten the handknobs.

**3.**

**Hexagon screw max. torque setting: 50 Nm.**

- Centre the disc aligner to the disc, by sliding it with the sliding piece through the mounting brackets.
- Use the hexagon key to tighten the hexagon screws, which will ensure the fixation of sliding piece and mounting brackets.

# PARTS LIST USM2002-B1

876070

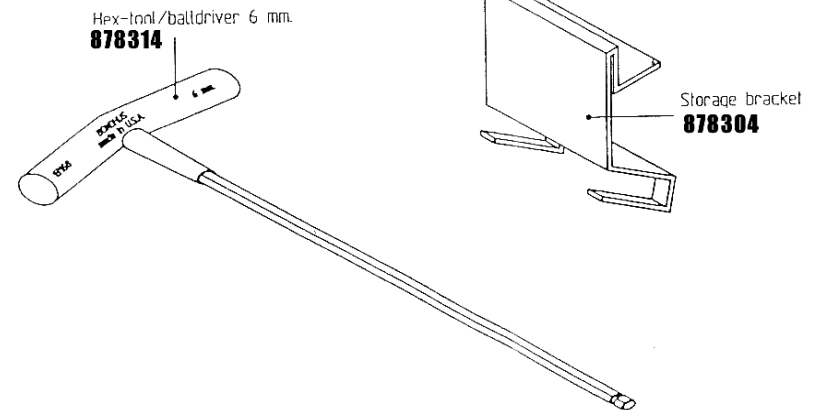
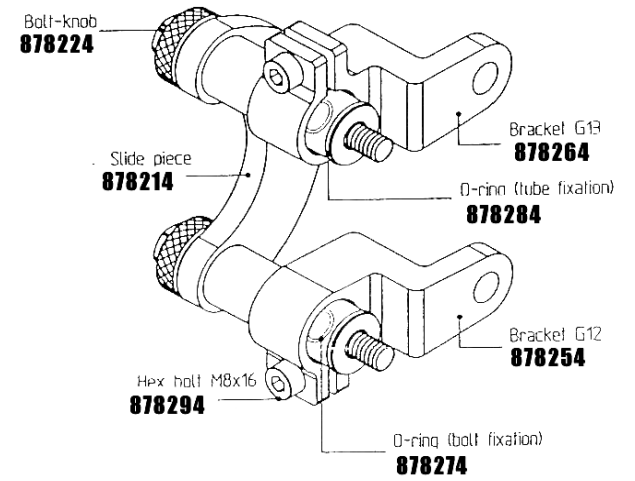

## **INSTALLING THE AUXILIARY DRIVE UNIT**

This package includes a passenger car drive yoke (#878105) and in some cases an optional 4X4 drive yoke (#877040). Either yoke is attached to the rotor with a single lug nut. Be careful to install the yoke with the V-notch firmly against the axle and tighten securely. Rotate the rotor so that the yoke crossbar is horizontal.

Wheel the drive unit into position so that the shaft and nylon coupler is aimed at the center of the axle. Rotate the coupler so that the slot is horizontal. Adjust the height of the drive unit by releasing the ratchet locking handle and rotating the large wing nut on the threaded shaft. Wheel the drive unit forward, engaging the nylon coupler onto the drive yoke crossbar, being sure to leave a ¼" gap in the rear of the slot. Lock the rear caster on the drive stand.

Turn the drive unit "ON" in the direction of the arrow located on the lathe body. Improper rotation will damage tool bits. If unit is turning in the wrong direction, turn the power off before changing the directional switch. Check to see that it runs smoothly. Of there is any shaking or oscillation, a slight height adjustment of drive unit using the large wing nut will smooth out the rotation.

## INSTALLING THE AUXILIARY DRIVE UNIT DIAGRAM

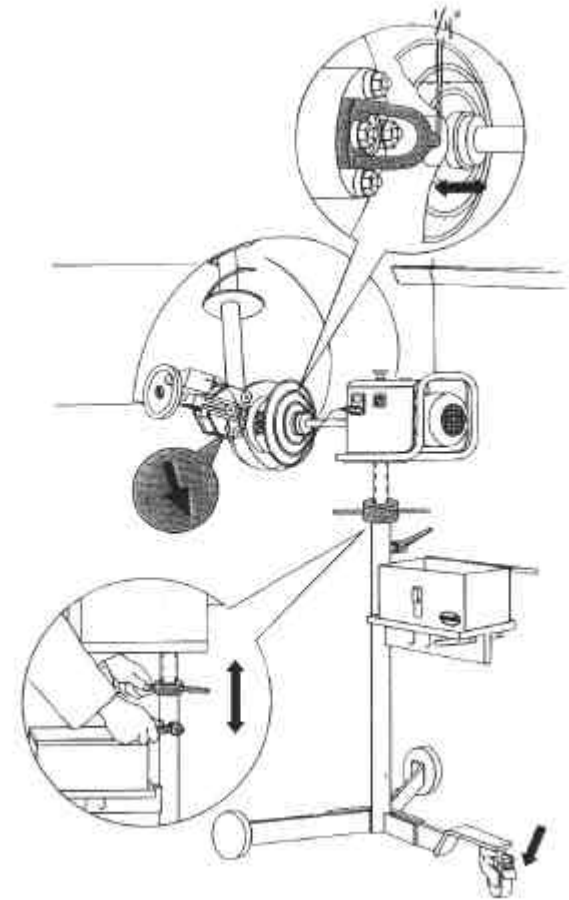

## **LATHE OPERATION AND MACHINING TECHNIQUE**

Plug your lathe into the receptacle on the auxiliary drive unit. While the drive unit is rotating the rotor, turn the handwheel clockwise to position the tool holders slightly over the friction area.

Carefully adjust the left and right tool holders until each bit makes surfaces contact for a full 360 degrees. Note the reading on each adjustment knob, and retract the bits a few numbers. Now continue turning the large handwheel clockwise until the tool holders are past the inner friction surface and are almost touching the hat section of the rotor. Turn the adjusting knobs back to the original reading plus an additional one-half mark (.002) for a proper finish cut. Each number is a 0.1 millimeter or .004 inch. For severely grooved or warped rotors the lathe may take a maximum cut of two marks or .008 inches per side. Push the power feed switch to the rear position I to machine outward away from the axle. Rotate the clutch knob on the handwheel clockwise to engage the feed. The handwheel will begin rotating counter clockwise.

Once the lathe has made a complete pass over the friction surface, inspect to see that both sides of the rotor have been completely machined. If the rotor was severely grooved or warped, a second pass may be required.

After machining is complete, check the rotor thickness with your micrometer to ensure it is above minimum allowable thickness.

After machining the rotor and removing the lathe, the friction surface may be dressed to remove any directional pattern. Use the optional hand burnisher (#434771) while drive unit is turning approximately 30 seconds. This will assist in eliminating brake clicking by leaving a smooth non-directional finish.

**LATHE OPERATION AND MACHINING TECHNIQUE**  
**DIAGRAM**

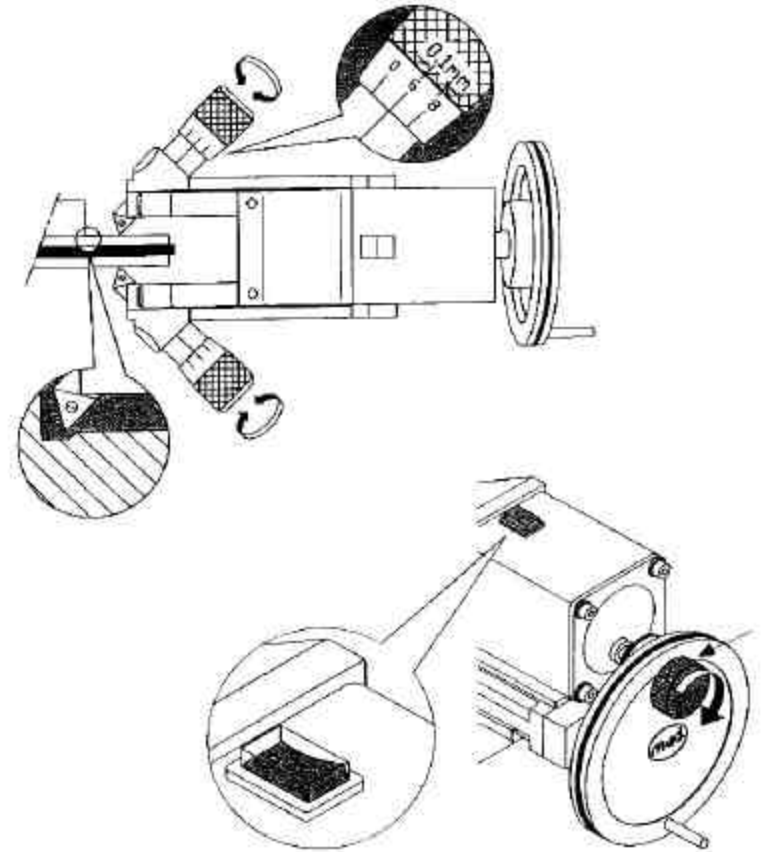

## TROUBLE SHOOTING

### *Surface finish rough.*

Cutting depth too great.  
Reduce to .004" (0.1mm) maximum.

Tool bit worn.  
Turn bit to new surface or replace.



Rotation in wrong direction.  
Change rotation to follow the arrow  
on the lathe.

Wheel bearing worn or loose.  
Adjust or replace bearing.

*Chatter noise and "herringbone"  
pattern on rotor.*

Tool bit loose.  
Tighten bits.

Lathe is loose.  
Tighten bolts.

Harmonic vibrations.  
Use silencer band.

Check wheel bearings.

*Power feed motor stalling.*

Tool slide too tight.  
Check slide for debris; clean/lube as  
required.  
Check for damage.  
Belt too tight.

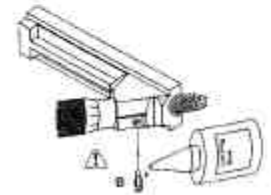

## TROUBLE SHOOTING (CON'T.)

*Power feed not operating.*

Belt too tight or loose.  
Adjust to ¼" (6mm) slack.

*Tool bit knobs hard to adjust.*

Tension adjustment too tight.  
Use socket wrench to adjust  
Tension nuts.

Debris or damaged bit holders.  
Remove and clean with fine emery cloth  
lubricate, and reinstall.

*Drive unit oscillating excessively.*

Drive yoke crossbar misaligned.  
Ensure the inner "v" is snug against hub.

Inadequate coupling clearance.  
Move drive unit back to leave a minimum of a  
¼" (6mm) clearance.

Lateral (left to right) position is out of limits.  
Adjust position of drive unit (center unit) to  
eliminate binding.

Height adjustment is out of limits.  
Adjust height of drive unit to eliminate binding.

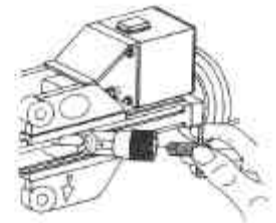
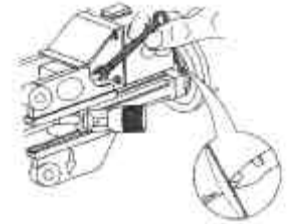

## PARTS BREAKDOWN

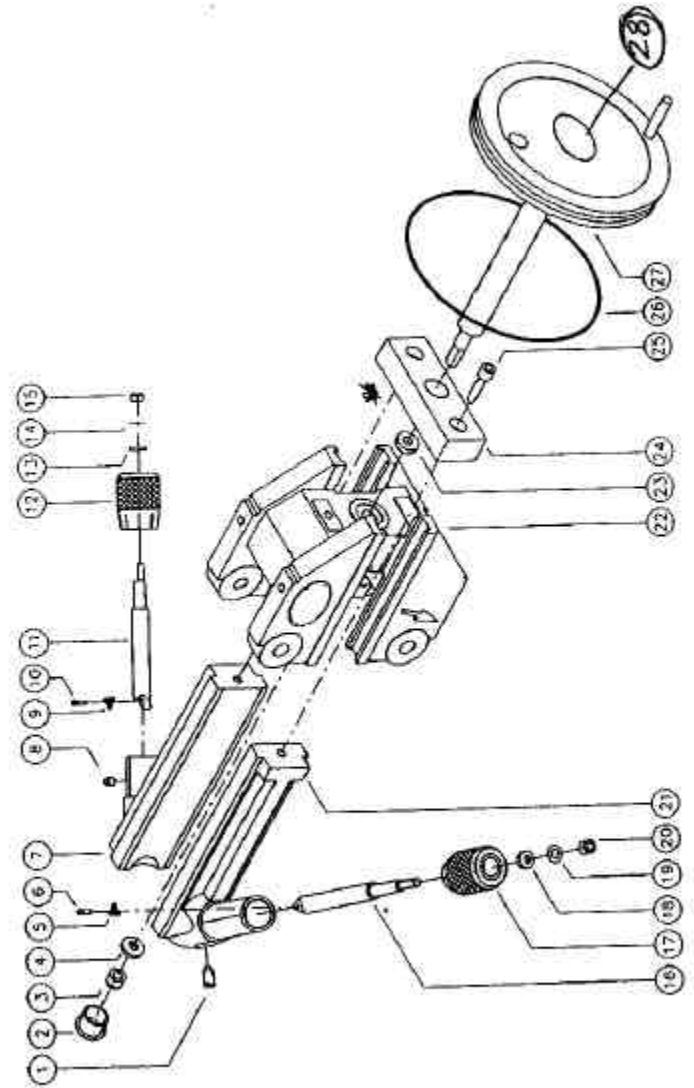

## LATHE PARTS BREAKDOWN

<u>Reference Numbers</u>	<u>Description</u>	<u>Part Numbers</u>
1 and 8	Lock Screw (Slot Head)	878110
2	Cap	877000
3	Self Locking Nut (M8)	870800
4	Washer	871400
5 and 6	Bit and Screw (Pkg. Of 5)	878052
5 and 6	Bit and Screw (Pkg. Of 10)	878051
7 and 21	Slide (Right and Left)	877028
9 and 10	(See 5 and 6 above)	
11	Bit Holder, Angeled (Right)	878100
12 and 17	Adjusting Knob	877003
13 and 18	Washer	871401
14 and 19	Spring Washer	871402
15 and 20	Self Locking Nut (M6)	871900
16	Bit Holder, Angeled (Left)	878101
22	Lathe Body	877114
23	Washer	871403
24	Cross Bar Connection	877030
25	Bolt (M6 X 20)	870902
26	O-Ring	872800
27	Handwheel/Spindle	877005
28	Accu-turn Decal	875111
Optional: 29	Extension Kit	878130



## POWER FEED PARTS BREAKDOWN

<u>Reference Numbers</u>	<u>Description</u>	<u>Part Numbers</u>
1	Spring Washer	871415
2	Bolt (M6 X 12)	870911
3	Frame	877010
4	Lock Washer (M6)	878127
5	Bolt (M6 X 40)	870913
6	Switch Cover Boot	877006
7	Switch	877007
8 and 12	Plastic Sleeve (6 X 10 X 15)	878119
9	Cord Protector / Gromet	870143
10	Line Cord Assembly	870148
11	Decal	877009
13	Adjusting Nut (M6)	871900
14	Jamb Nut (M6)	878120
15	Nut (M5)	870805
16	Spring Washer (M5)	871416
17	Motor Cover	877014
18	O-Ring	872801
19	Motor Assembly, 110V	877011
20	Toothed Belt	877012
21	Plastic Washer	878121
22	Grub Screw (M4 X 6)	878122
23	Toothed Wheel	877013
24	Bolt (M5 X 100)	870912
25	Friction Clutch	877015
26	Spring Washer (M6)	871402
27	Dowel Pin (3mm X 16mm)	877038
28	Plastic Washer (M6)	871414
29	Clutch Knob	877016
30	Toothed Wheel	877017
25-30 w/ Handwheel	Handwheel/Clutch Gear Assembly	871600

**ACCESSORIES AND CASE DIAGRAM**

*8750 Only*

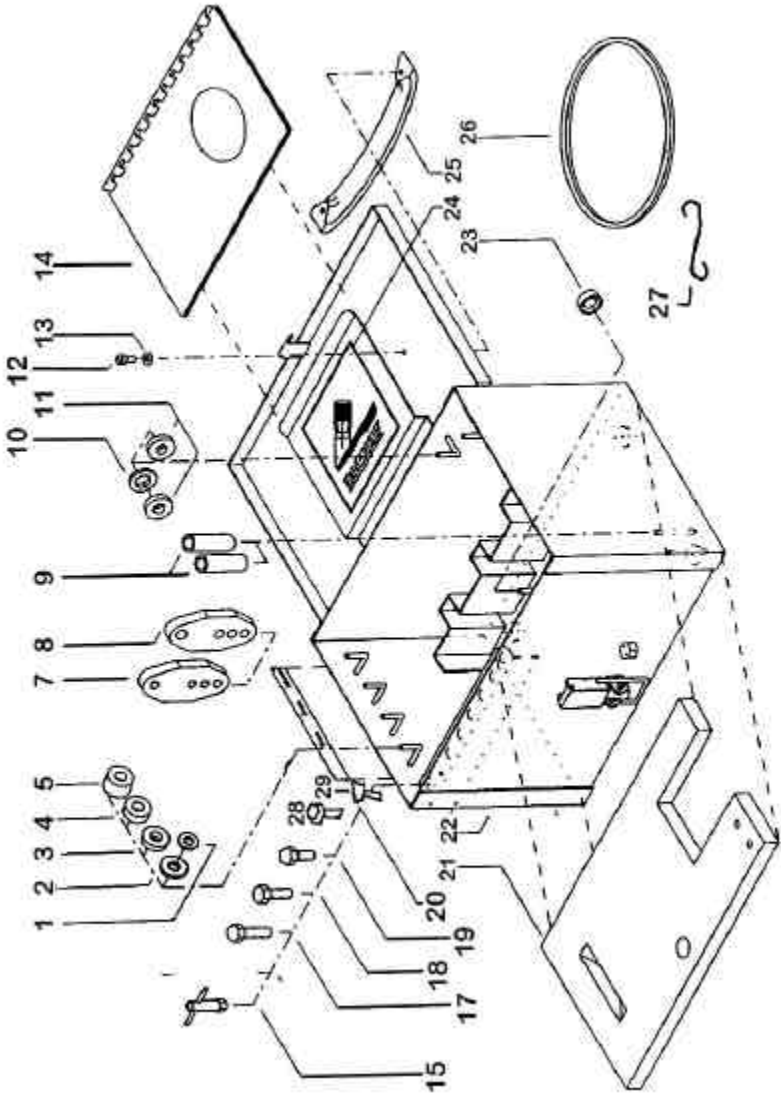

## ACCESSORIES AND CASE

8750 ONLY

<u>Reference Numbers</u>	<u>Description</u>	<u>Part Numbers</u>
1	Washer, M10 (4 req'd)	871404
2	Shim Washer, 3mm (2 req'd)	871405
3	Shim Washer, 5mm (2 req'd)	871406
4	Shim Washer, 7mm (2 req'd)	871407
5	Shim Washer, 10mm (2 req'd)	878123
7	Threaded Mounting Plate (Red, 2 req'd)	877019
8	Unthreaded Mting Plate (Blue, 2 req'd)	877020
9	Spacers (2 req'd)	871903
12	Bolt, M6 (2 req'd for handle)	870903
13	Washer, M6 (2 req'd)	871410
14	Owners Manual/Parts List	333008
15	Socket Wrench, 10mm	877021
17	Bolt, M10 X 1.5 X 40mm (2 req'd)	870904
18	Bolt, M10 X 1.5 X 30mm (2 req'd)	870905
19	Bolt, M10 X 1.5 X 25mm (2 req'd)	870906
20	Label	878125
21	Wooden Insert	870225
22	Steel Carrying Case	870224
23	Conical Rings (5 req'd)	871902
24	Decal	875110
25	Handle	871500
26	Silencer Band	434061
27	Caliper Hook	877023
28	Bolt, M9 X 1.25, 30mm (2 req'd)	879103
29	Bolt, M10 X 50mm (2 req'd)	878124

**ACCESSORIES AND CASE**

*8800 Model*

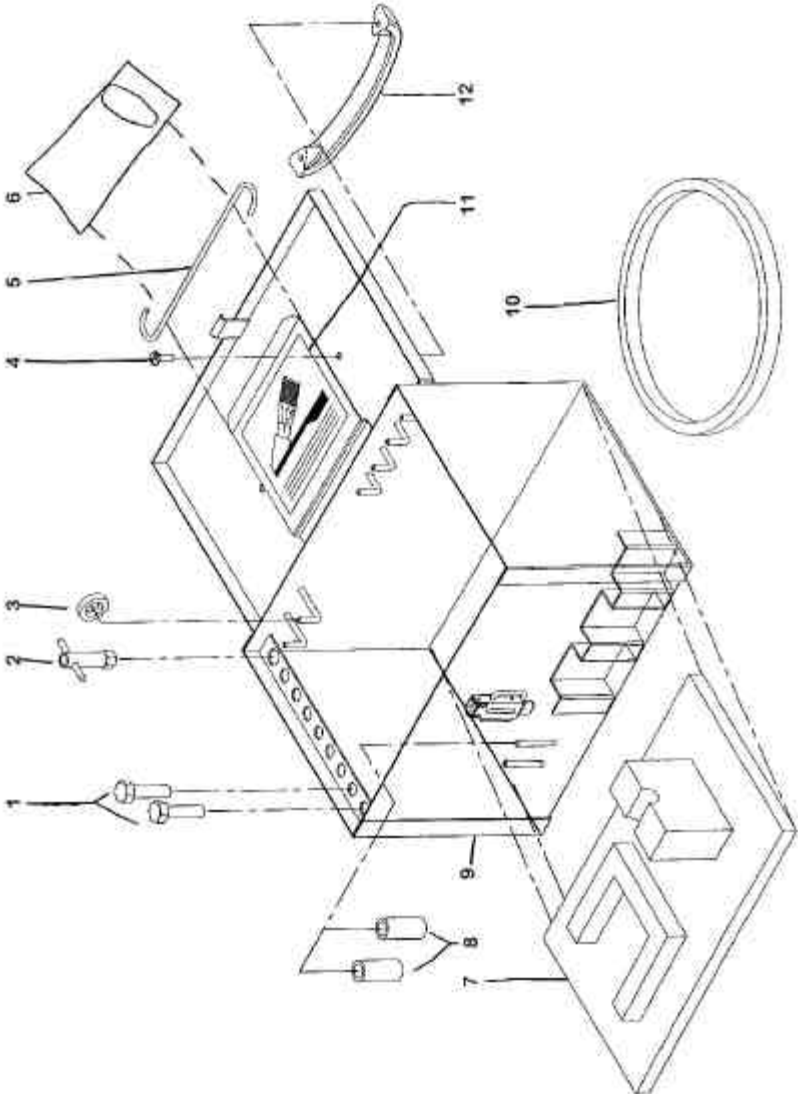

## ACCESSORIES AND CASE

*8800 Only*

<b>Reference Numbers</b>	<b>Description</b>	<b>Part Numbers</b>
1	Bolt, M9X1.25X30mm (2 req'd)	879103
2	Socket Wrench, 10mm	877021
3	Conical Rings (5 req'd)	871902
4	Bolt, M6 (2 req'd for handle)	870903
5	Caliper Hook	877023
6	Owners Manual/Parts List	333008
7	Wooden Insert	870225
8	Spacers (2 req'd)	871903
9	Steel Carrying Case	870224
10	Silencer Band	434061
11	Decal	875110
12	Handle	871500

## DRIVE UNIT AND STAND DIAGRAM

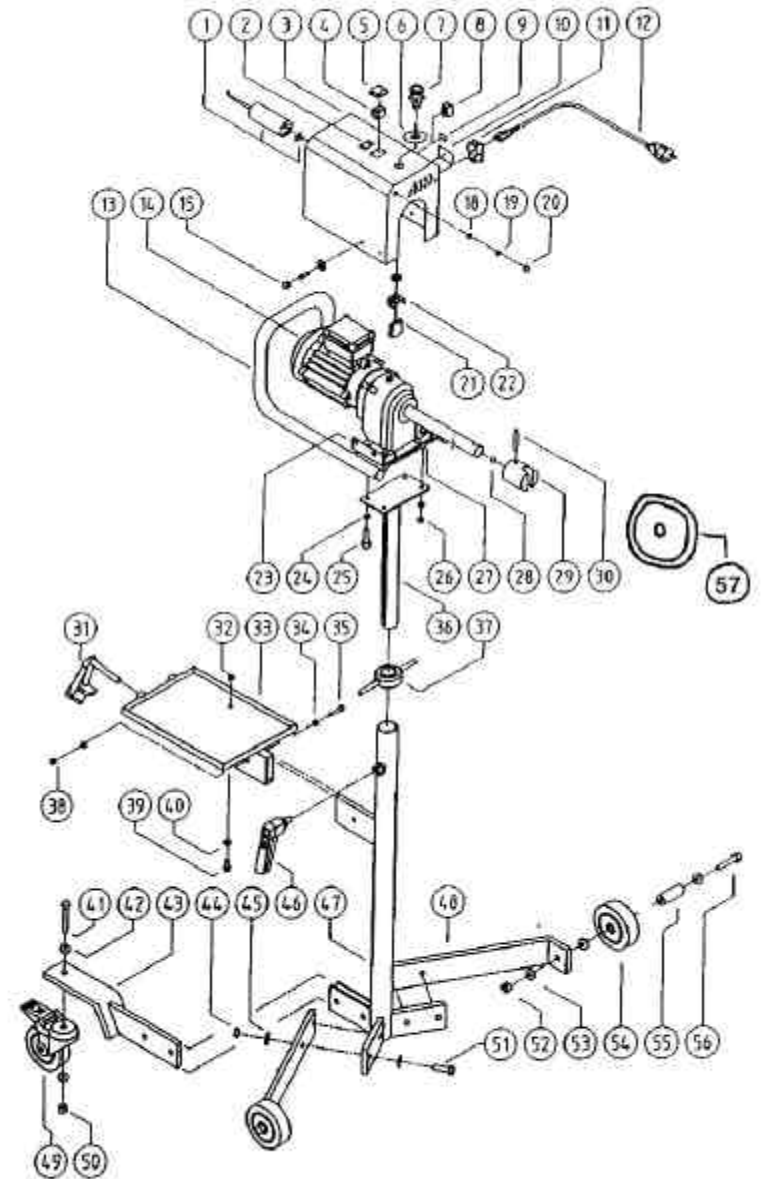

## DRIVE UNIT AND STAND

<b>Reference Numbers</b>	<b>Description</b>	<b>Part Numbers</b>
1	Condenser	860132
2	Decal, "Direction"	860195
3	Cover	877042
4	Switch, direction (left/right)	877043
5	Switch cover	860159
6	Shield	860157
7	Emergency button	860155
8	Switch, on/off	877044
9	Decal, "on/off"	860196
10	Identification plate	877045
11	Inlet/outlet connector	860154
12	Cable 110V, inlet	877046
13	Protection bar	860144
14	Motor-Gear Assembly, 110 VAC/60 Hz	860123
15	Plastic cap (M6), Bolt (M6 X 8), Plastic washer	860198
18	Plastic washer	860176
19	Nut (M8)	870803
20	Plastic Cap (M8)	860171
21	Contact switch	860156
22	Connector element	860150
23	Foot plate	860161
24	Plain washer(M10)	871404
25	Bolt, M10 X 1.5 X 30mm	870905
26	Nut (M10)	860104
27	Bolt, M10 X 35mm	
28	Rubber Ball	878108
29	Drive coupling	860135
30	Parallel roll pin	860118

**DRIVE UNIT AND STAND (Continued)**

<b>Reference Numbers</b>	<b>Description</b>	<b>Part Numbers</b>
31	Drive adapter, yoke	878105
32	Nut (M8)	870803
33	Holder, steel box	877001
34	Plain washer (M8)	871411
35	Bolt, M8 X 30mm	870907
36	Spindle	860137
37	Adjusting Nut	870802
38	Nut (M8)	870803
39	Bolt, M8 X 25mm	870908
40	Plain washer (M8)	871411
41	Bolt, M12 X 60mm	870605
42	Plain washer (M12)	871412
43	Bracket swing	877002
44	Nut (M12)	870804
45	Plain washer (M12)	871412
46	Fixation handle (M12 X 1.75)	871501
47	Spindle housing	877004
48	Leg bracket	877018
49	Locking caster assembly	877026
50	Nut (M12)	870804
51	Bolt, M12 X 45mm)	870909
52	Nut (M12)	870804
53	Plain washer (M12)	871412
54	Wheel, new style	877024
55	Axle bearing	877037
56	Bolt, M12 X 80mm	877039
57	Safety Cap, SK-508	860028
58	Wiring harness	876198
Optional:		
	Chip Tray SK-405	876088
	Short Stand	878114

## ELECTRICAL DIGRAM

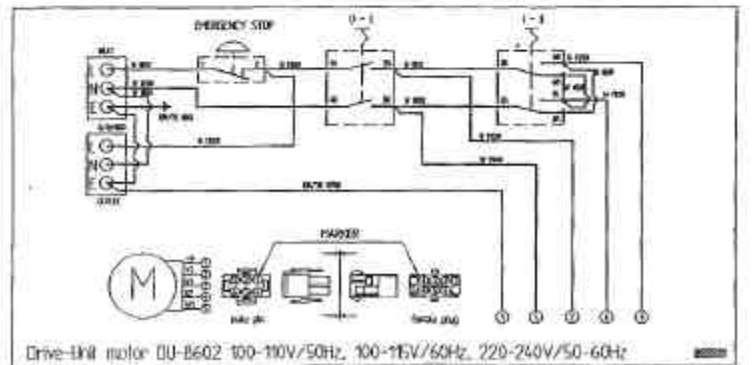
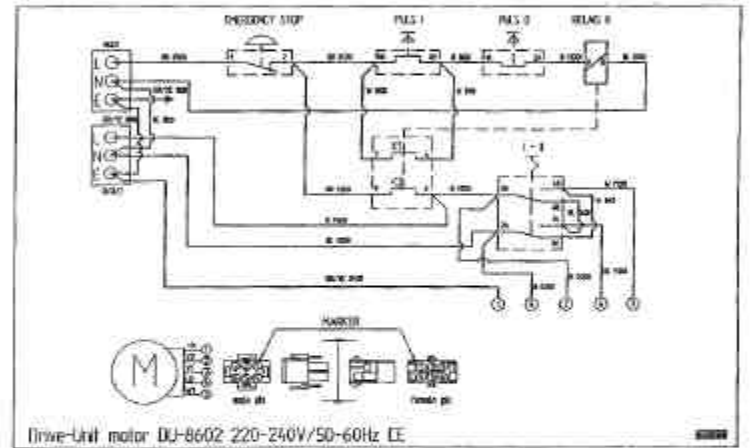
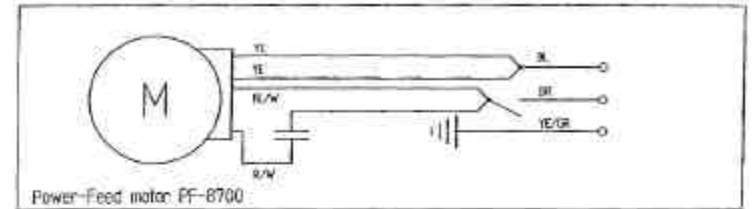

## MAINTENANCE

Unless damaged by rough usage, your lathe should require a minimum of care. Keep all parts clean and dry, and keep the lathe and accessories in the case to prevent accidental damage or loss. When needed, clean and lubricate as follows:

Disconnect crossbar (24) using allen key and remove tool slides (7 & 21), checking for damage or binding. Clean and lube as required.

Remove locking screws (1 & 8) and unscrew tool bit holders. Carefully clean the bit holders and inside surfaces of the tool slides with a fine emery cloth. Lubricate sparingly with light machine oil and check for smooth operation.

When reinstalling tool slides, push them firmly against the crossbar before reassembling to avoid the chance of misalignment.

Inspect all parts periodically for signs of damage or wear.

Adjust power feed belt periodically to ¼" (6mm) slack. Check coupling for excessive wear and replace as necessary for smooth operation.

## SPECIFICATIONS AND TECHNICAL DETAILS

### *Lathe*

Lathe body and tool slides	GGG-40 Mehanite cast iron, Case hardened
Adjustment knobs	Stainless steel
Handwheel	Polished aluminum
Tool bits	Ground carbide (6-sided type)
Maximum rotor travel	4.5"
Maximum rotor capacity	1.57" (40mm) thick
Weight, complete (8750)	27.5 lbs.
(8800)	28.4 lbs.
USM box	14.2 lbs.
Weight, lathe	14.9 lbs. (6.77 kg.)
Lathe dimensions (length x width x height)	12.2" x 9.05" x 6.5"
Power feed motor	Synchronous stepping 110V 60Hz., 9.6 RPM
Feed speed RPM	.0042" (.1mm)/rev. at 95

### *Drive Unit*

Motor	110VAC 60 Hz. Single phase
Spindle drive speed	100 RPM
Weight	95.6 lbs.



Model 8750 / 8800

On-Car Brake Lathe

Owner's Manual

#333008  
07/01



For Technical assistance or service information,  
please call 1-80-551-ACCU (2228)

Accu Industries, Inc.  
11126 Air Park Road/Ashland, VA 23005  
804-798-8944/Fax 804-798-6742  
[www.accu-turn.com](http://www.accu-turn.com)

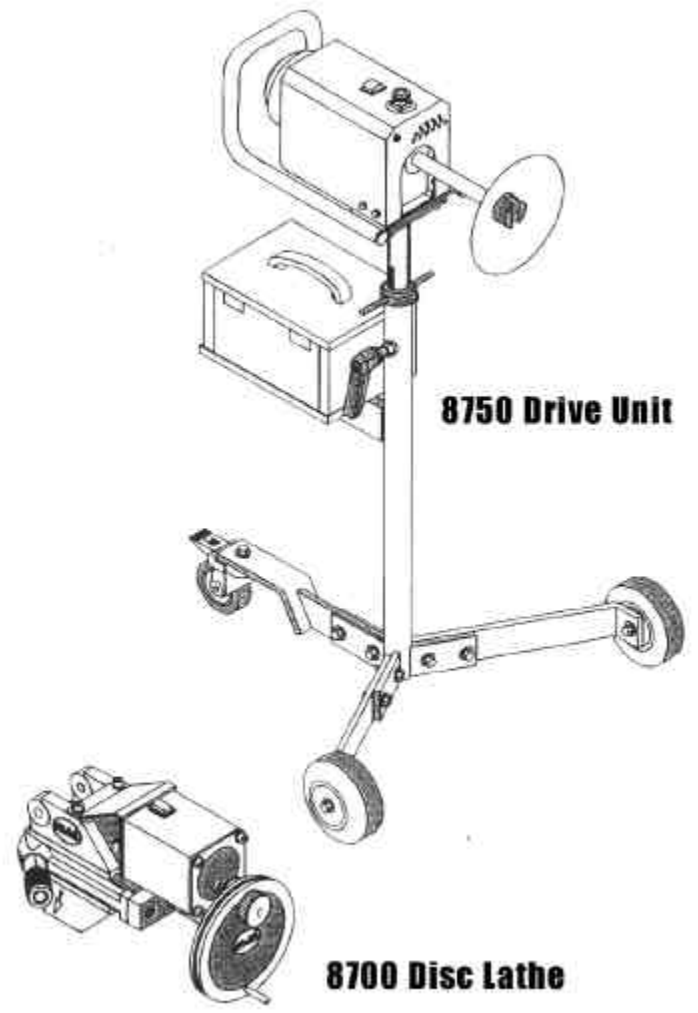

**8750 Drive Unit**

**8700 Disc Lathe**