

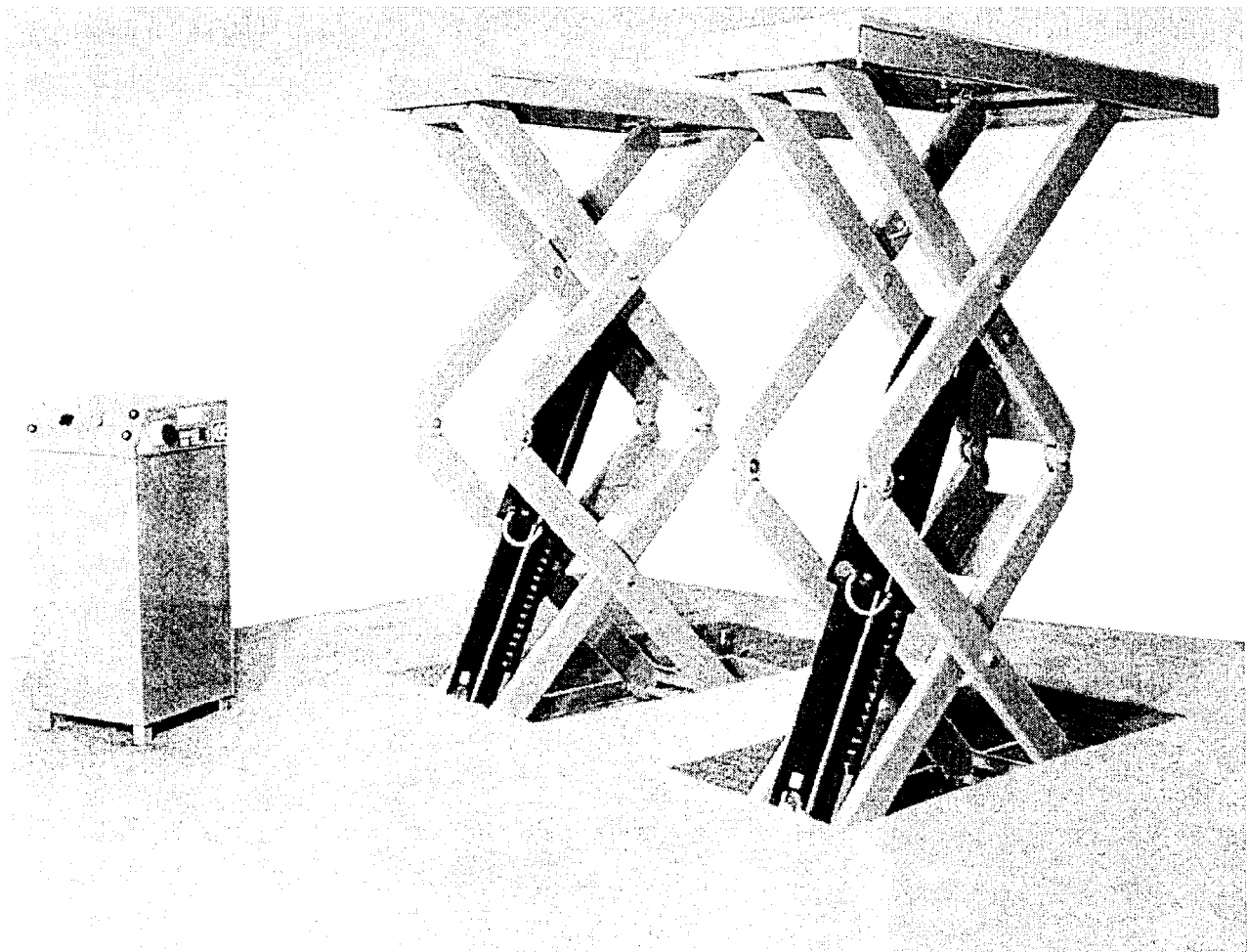

MODEL # AC35196FM



INSTALLATION AND OPERATION MANUAL

SAVE THESE INSTRUCTIONS

READ ALL INSTRUCTIONS
BEFORE USING LIFT

MAR 2000 6-2220



Accu International, Inc.

P.O. Box 15540 Richmond, VA 2327

804-798-8922

www.accu-turn.com 1-800-551-2228

TABLE OF CONTENTS	PAGE
1 IMPORTANT SAFETY INSTRUCTIONS	2
2 SPECIFICATIONS	3
3 CONTENTS	4
4 TOOLS REQUIRED FOR INSTALLATION:	4
5 INSTALLATION INSTRUCTIONS	5
5.1 BAY LAYOUT.....	5
5.2 POSITIONING OF THE RUNWAYS	6
5.3 HYDRAULIC INSTALLATION	8
5.4 ELECTRICAL INSTALLATION	9
5.5 BLEEDING THE HYDRAULIC SYSTEM	11
5.6 PNEUMATIC LINE INSTALLATION	12
5.7 LEVELING AND ANCHORING PROCEDURE	14
5.8 CHECKING LIMIT SWITCHES.....	15
6 OPERATION OF THE LIFT	16
6.1 INITIAL OPERATION	16
6.2 BEHAVIOUR AND USE DURING OPERATION.....	18
6.3 LIFTING AND LOWERING	19
7 RESITING	19
8 MAINTENANCE	20
9 TROUBLESHOOTING	21
9.1 PROBLEMS, CAUSES AND REMEDIES	21
9.2 EMERGENCY LOWERING OF THE LIFT	22
10 TECHNICAL DATA	23
11 INDEX	24
11.1 HYDRAULIC SCHEMATIC.....	24
11.2 ELECTRICAL SCHEMATIC	25
12 PARTS MANUAL	26
12.1 LIFT ASSEMBLY PARTS LIST.....	27
12.2 HYDRAULIC/AIR DIAGRAM.....	28
12.3 PARTS LIST.....	29

1 IMPORTANT SAFETY INSTRUCTIONS

When using this lift, basic safety precautions should always be followed, including the following:

1. Read all instructions.
2. Care must be taken as burns may result from contact with hot parts of the lift.
3. Do not operate the lift with a damaged cord, or if the lift has been damaged, until it has been examined by a qualified service person.
4. Never allow the cord to be positioned under the lift or in an area where it could get crushed or come in contact with hot or moving parts.
5. If an extension cord is necessary, a cord with a current rating greater than or equal to that of the lift should be used. Extension cords rated for less amperage than the lift may overheat. Care should be taken to arrange the cord so that it will not be tripped over or pulled.
6. Never unplug the lift from the electrical outlet during operation. Always disconnect power when not in use. Never yank the cord to pull plug from outlet. Grasp plug and pull to disconnect.
7. To protect against the risk of fire, do not operate lift in the vicinity of open containers of flammable liquids.
8. Adequate ventilation should be provided when working on internal combustion engines.

SAVE THESE INSTRUCTIONS

2 SPECIFICATIONS

Capacity:
 Overall Width:
 Width Between Runways:
 Platform Length:
 Max. Raised Height:
 Collapsed Height:
 Shipping Weight:
 Power Requirements (Standard):
 Lifting Time:

7000 lb.	3175 kg
74"	1880 mm
31 ½"	800 mm
60" (83" Extended)	1530 mm (2110 mm Extended)
69"	1753 mm
0"	0 mm
1543 lb.	700 kg
230V, 1Ph. 60Hz., 2hp	
45 Seconds	

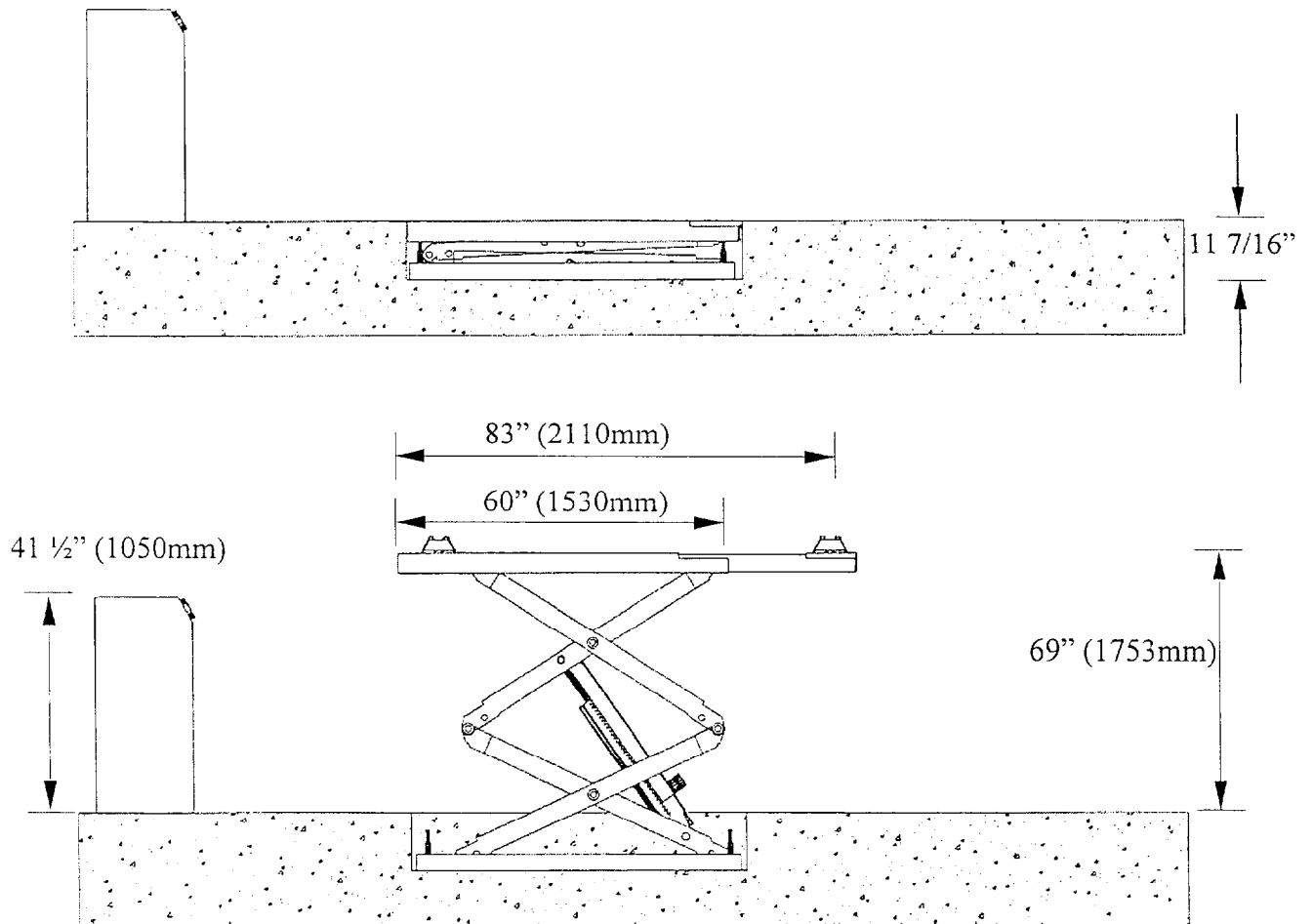

Figure 1 - Lift Dimensions

CHECK CONTENTS OF ACCESSORY BOX WITH PACKING LIST ENCLOSED IN BOX.

3 CONTENTS

The complete lift contains:

1. The **main structural components** are pre-assembled and packaged one on top of the other.
2. The remaining parts are packed separately in **2 boxes**.

Main Structural Components include:

- 1pc. - Left Side Main Frame Assembly; Runway, Double Scissors and Base Frame
- 1pc. - Right Side Main Frame Assembly; Runway, Double Scissors and Base Frame

Box 1 Contents:

- 1pc. - Control Desk

Box 2 Contents (Accessories):

- 1pc. - Hydraulic Hose (Labeled "A")
- 1pc. - Hydraulic Hose (Labeled "B")
- 1pc. - Hydraulic Hose (Labeled "C")
- 1pc. - Hydraulic Hose (Labeled "E")
- 1pc. - Pneumatic Line
- 4pcs. - Rubber Pads
- 4pcs. - Shim Plate, 1/16"thk.
- 4pcs. - Shim Plate, 1/8"thk.
- 4pcs. - Shim Plate, 1/4"thk.
- 1pc. - Hardware Kit (comes with separate packing list)

- 1pc. - Owners Manual
- 1pc. - ALI manual "Lifting It Right"
- 1pc. - Automotive Lift Safety Tips
- 1pc. - Automotive Lift, Operation, Inspection, and Maintenance manual

4 TOOLS REQUIRED FOR INSTALLATION:

- Rotary Hammer Drill or Similar, 1/2" Concrete Drill Bits
- 4' Level
- Metric and Imperial Wrenches and Sockets
- Hammer (for anchor installation)
- Pry Bar (for shim installation)
- Chalk Line (for lift location)
- Tape Measure
- Side Cutters (to cut shipping straps)
- Screw Drivers
- Hydraulic Fluid ISO 32 (10 weight hydraulic oil) - (20 liters / 5.3 Gal.)

5 INSTALLATION INSTRUCTIONS

When the lift arrives on site, please read the owner's manual completely. Check the contents to make sure no parts are missing before starting installation. Gather all the tools listed and make sure the installation instructions are fully understood before commencing with the installation.

Only when the hydraulic system has been filled with oil, bled, and the runways have been raised to the final top position, is it possible to connect the pneumatic lines.

IMPORTANT: Lifts should only be installed on level concrete floors with a minimum floor thickness of five (5) inches. Concrete must have a minimum strength of 4,000 psi, and should be aged thirty (30) days prior to installation.

5.1 BAY LAYOUT

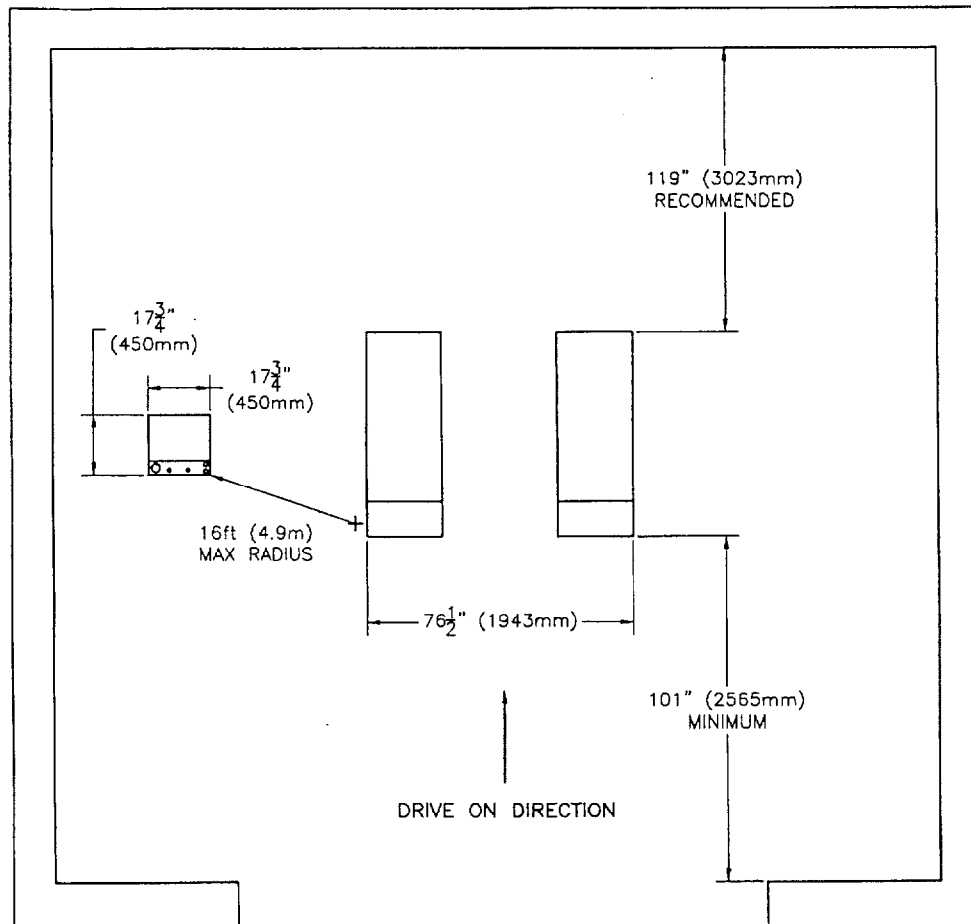

Figure 2 - Typical Bay Layout

5.2 POSITIONING OF THE RUNWAYS

1. Before installation, the bay layout should be prepared as shown in Figure 4. This can be completed with the aid of the In Ground Frame Kit (optional part # FR3.5).
2. When transporting the runways to the site, always use suitable means with sufficient load capacity. The same also applies for the slinging means used (ropes, chains, etc.). The runways must be lifted according to their center of gravity to prevent slipping or dropping during transport. Always pick up the runways on the underside of the base frame.
3. Raise runways to a vertical height of approximately 31½" (800mm). This may be done by hand (use 2-4 helpers) or with the aid of suitable hoisting equipment (e.g. crane). In both cases it is important to **ensure that the gear racks have settled before releasing the runways.**
4. Once the lift has been fully raised, place the 4"x4"x19" piece of wood (supplied) into the baseframe weldment as shown in Figure 3. **This must be done so that if the lift comes off the safeties during installation, the scissors will not collapse** (i.e. they will jam against the wood block). The blocks may be removed once installation is complete.
5. Position both base frames in the foundation according to the drive-on direction of the lift (see Figure 2).

- P1** Primary cylinder (Left Side)
- P2** Secondary cylinder (Right Side)

6. Align the runways parallel to each other and in the drive-on direction (Figure 2).
7. Place the control desk in a suitable position.

The standard hydraulic and pneumatic lines are designed such that the control desk can be installed at a maximum radius of 16ft. (4.9m) from the lift.

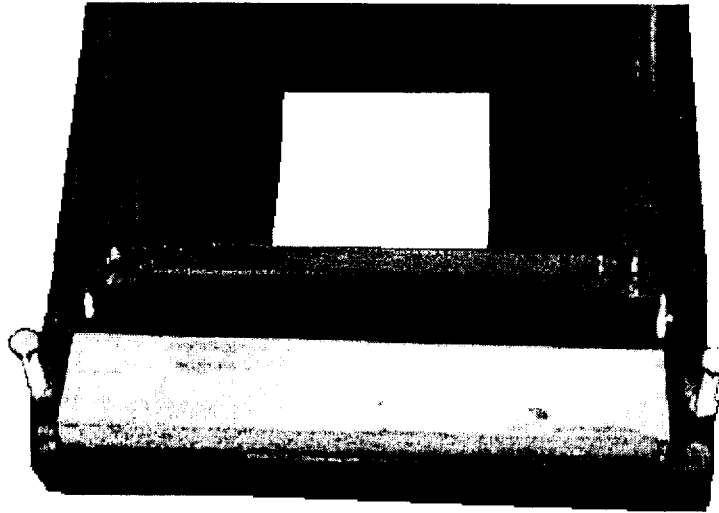

Figure 3 – Insert 4"x4" Wood Block as a Safety Mechanism During Installation

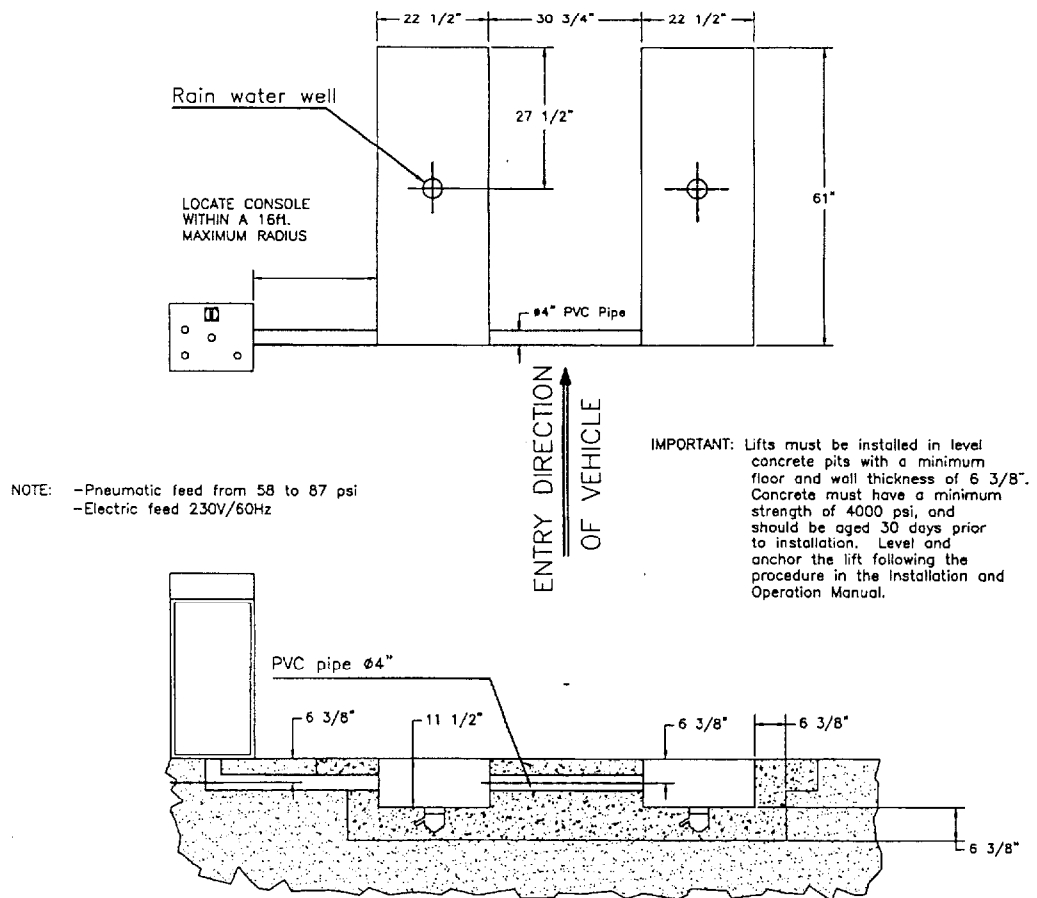

Figure 4 - Foundation Layout

5.3 HYDRAULIC INSTALLATION

Before laying out the hydraulic lines, the coupling should be sealed (with adhesive tape, textiles, plastic, etc.), to prevent dirt or other objects from entering the lines during installation (see Figure 5).

NOTE: To connect the hydraulic lines, both runways must be raised to a vertical height of approximately 31½" (800mm). This may be done by hand (use 2-4 helpers) or with the aid of suitable hoisting equipment (e.g. crane). In both cases it is important to ensure that the gear racks have settled before releasing the runways.

Connection of the lines

1. Remove the front panel of the control desk.
2. Feed the pre-assembled hoses through the PVC piping and connect them as shown in the hydraulic diagram (Figure 5).
 - Attach hydraulic hose "A" to cylinder P1 (left side).
 - Attach hydraulic hose "B" to cylinder P2 (right side).
 - Attach hydraulic hose "C" to the branch T fitting located at cylinder P1 (left side).
 - Attach one end of hydraulic hose "E" to cylinder P2 (right side), and the other end to the branch T fitting located at cylinder P1 (left side).
 - Attach the other ends of hydraulic hoses "A", "B", and "C" to the control desk to their corresponding marked connectors, and tighten well.

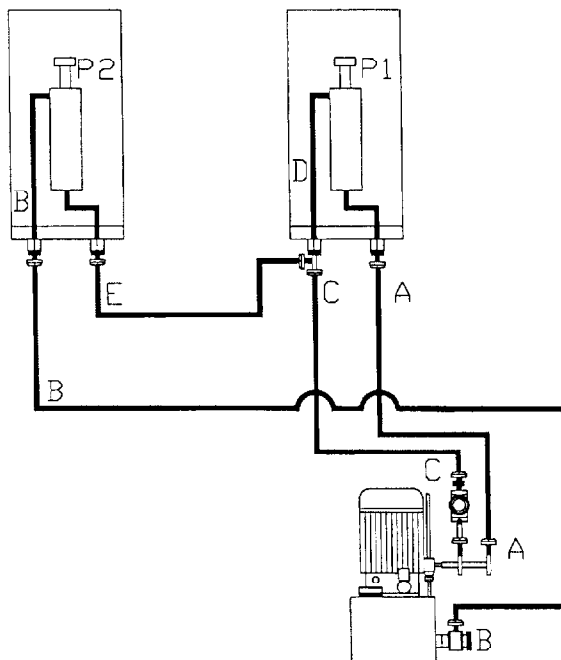

Figure 5 - Hydraulic Schematic. Reference letters for the hydraulic lines and points of connection that are shown in the figure, are the same as those found on the hoses.

NOTE: A detailed hydraulic schematic is included in the Index (Section 1)

Hydraulic connections

- A Pressure line, raising of the runways
- B Bleeding and oil return, cylinder P2
- C Oil discharge, cylinder P1
- D Oil return, cylinder P1 (automatic leveling)
- E Pressure line, cylinder P2

The copper seals used with the connectors can only be used once.

5.4 ELECTRICAL INSTALLATION

IMPORTANT: A QUALIFIED ELECTRICIAN SHOULD MAKE ALL FINAL ELECTRICAL CONNECTIONS

- Connect a power cord to the control desk as shown in Figure 6.
- Connect control lines (pre-fitted to the lift) to the control desk as shown in Figure 6.

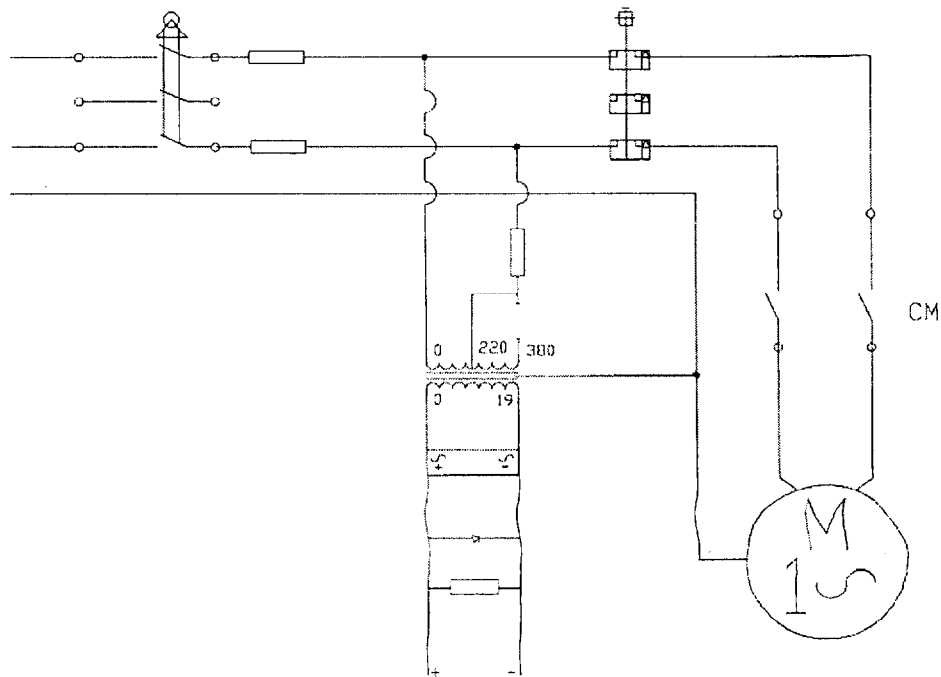

Figure 6 - Electrical Diagram

NOTE: A detailed electrical schematic is included in the Index (Section 2).

When all lines are connected, turn on the main switch (Figure 7, Item 1). Set the SELECTION switch to the required position, and check that the direction of the motor rotation is correct (counterclockwise) by pressing the UP key (Figure 7, Item 5). If the direction of rotation is not correct, interchange the two phases of the main switch.

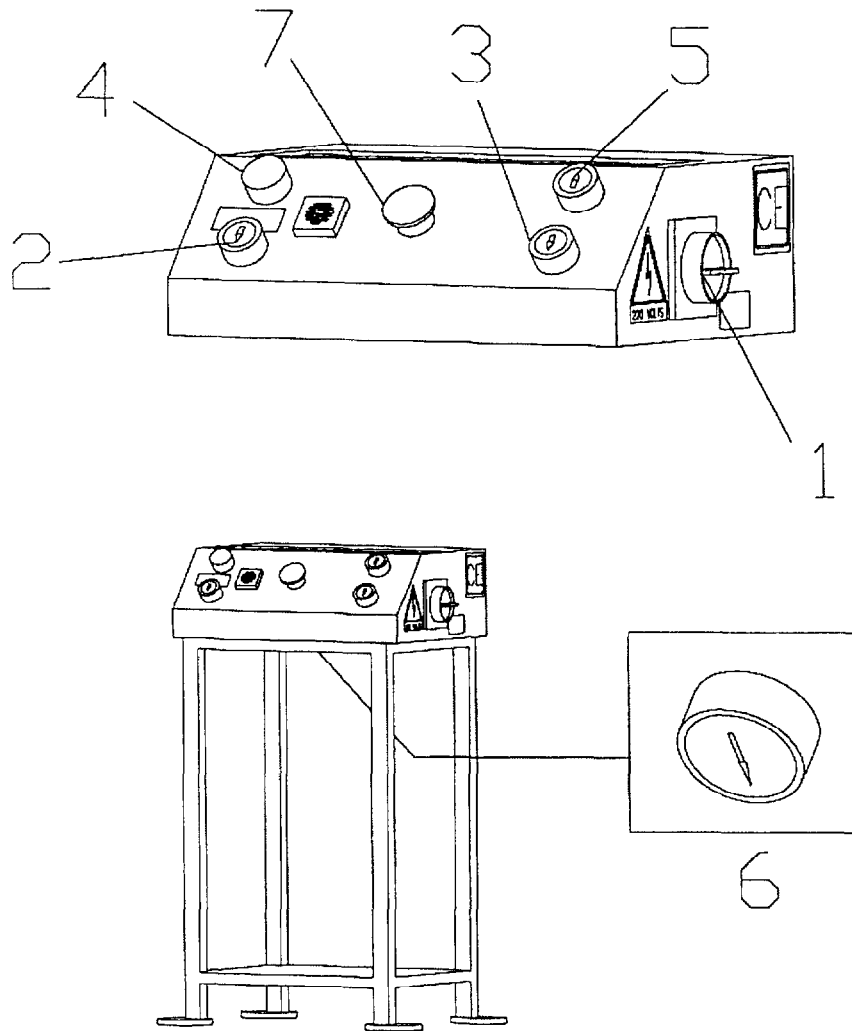

Figure 7 - Power unit and related controls

1. Main Switch
2. Key with double function: for engaging the gear racks, lowering below 15 ¾" (400mm)
3. DOWN key
4. Power Supply LED - ON/OFF
5. UP key
6. RELEASE key: TOP POSITION, PHOTOCELL
7. Emergency key

5.5 BLEEDING THE HYDRAULIC SYSTEM

1. Fill the hydraulic unit with approx. 10 litres (2.7 Gal.) of hydraulic fluid ISO 32.
2. Turn on the main switch.
3. Press the UP key and raise the runway P1 (primary cylinder) until it reaches the final top position.
4. Fill the unit with 5 more litres (1.35 Gal.) of hydraulic fluid.
5. To raise the runway P2 to the final top position, press the UP key (Figure 7, Item 5) and the RELEASE key simultaneously (Figure 7, Item 6 - having removed the front panel of the control desk). Hold these two keys pressed until both runways are raised fully to the final top position. Once the final top position has been reached, hold the keys pressed for a further 10 - 20 seconds to bleed the hydraulic system.
6. Connect the pneumatic system to disengage the gear racks.
7. To completely bleed the system, repeat this procedure a total of 3 times.

5.6 PNEUMATIC LINE INSTALLATION

The disengagement of the gear rack and the locking of the slip plates are carried out pneumatically. The site pneumatic supply (to which the pneumatic system of the lift is connected) may be equipped with a servicing unit composed of water separator, oiler and pressure reducer.

1. Raise the lift to the final top position.
2. Connect the pneumatic lines (pre-assembled on the runways) to the control desk according to the colour markings (Figure 8).

NOTE: Use the ¼" Polytube Adapter (Figure 8, Item 6) to join the supply line (L2) to L4 (12" (300mm) piece sliced from L3 - Accessory Box).

3. Connect the pneumatic system of the lift to a pneumatic supply on site.
4. Check the pneumatic control operations for proper performance. By pressing the DOWN key (Figure 7, Item 3), the gear racks are disengaged.
5. Press the DOWN key (Figure 7, Item 3), and lower the runways completely.
6. Bleed the hydraulic system once more.

After bleeding, the hydraulic system is ready for operation.

7. Replace the cover of the control desk.

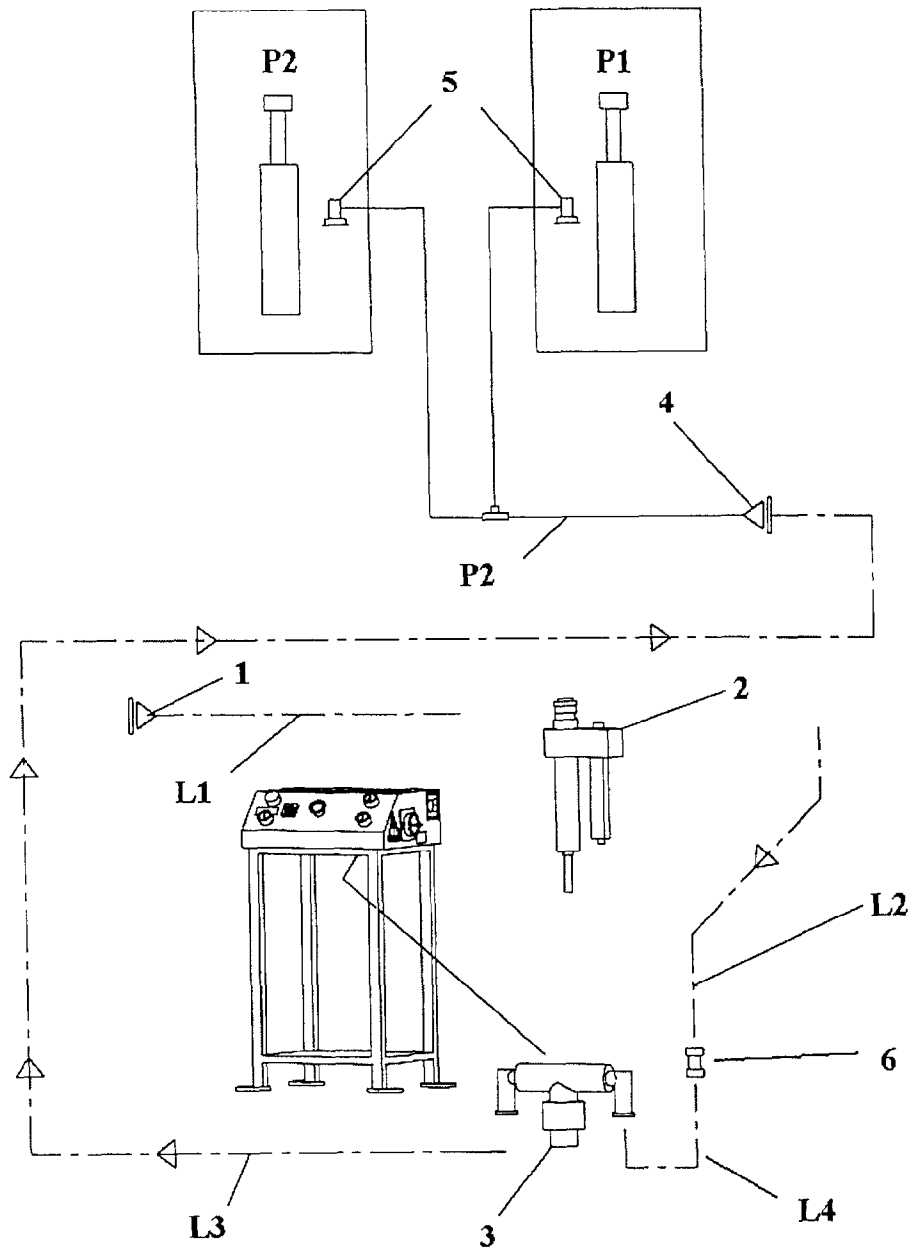

Figure 8 - Pneumatics Installation

1. Compressed air supply
2. Servicing unit placed on side of the control desk (optional)
3. Pneumatic solenoid valve
4. Connector to base frames
5. Cylinder for disengaging the upper gear racks
6. ¼" Polytube Adapter

Pneumatic lines

- L1 Pneumatic line to the servicing unit (optional)
- L2 Pneumatic line to the polytube adapter
- L3 Pneumatic line to the cylinders on the gear racks
- L4 Pneumatic line to the control the valve in the control desk

5.7 LEVELING AND ANCHORING PROCEDURE

When the supply lines are connected, shim and anchor the lift as described below.

NOTE: This is a very important procedure and time must be taken to do it correctly.

1. Raise the lift to a height of approx. 63" (1600mm) and settle the gear racks.
2. Using a 4' level, check the front-to-rear and side-to-side level of each individual runway, and the runway-to-runway level between the two units. Locate the highest point on the lift, and if leveling is required, level the units to the highest point using proper shims.
3. The lift must be leveled to the following tolerances:
 - 1/8" (3.2mm) front-to-rear over the entire length of each individual runway.
 - Zero side-to-side on each individual runway.
 - Zero side-to-side between the two runways.
4. Tighten all deck leveling bolts securely on the baseframe. Lower the runways onto the leveling bolts and adjust them to ensure the runways are leveled to the same tolerances as described above for the lowered position.
5. After proper levels are attained for both the raised and lowered positions, use a rotary hammer drill and a 1/2" concrete drill bit to drill through the floor in the four (4) anchor bolt location holes on each of the base frames. Make sure that the 1/2" concrete drill is in good condition. Refer to Figure 9.
6. Insert the 1/2" x 4 1/2" long wedge anchor bolts supplied, place a flat washer and nut on each anchor. Shim across the base frame from side to side and front to rear to fill the space between the floor and the base. Tighten anchor bolts securely.

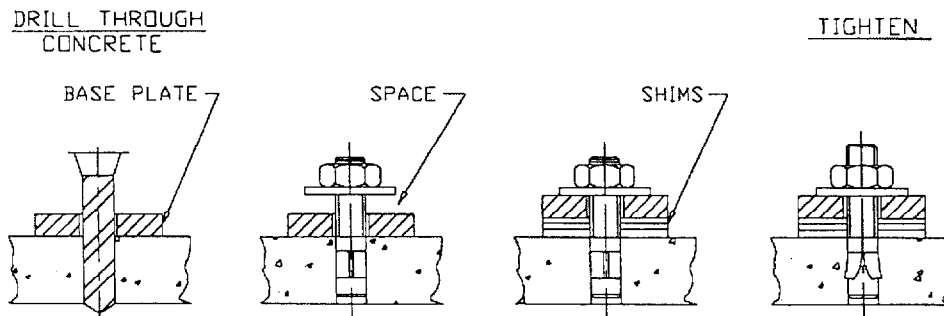

Figure 9 - Anchor Installation

7. Torque all anchor bolts to 150 ft. lb.
8. With all anchor bolts torqued as specified, operate the lift checking its full operation.

5.8 CHECKING LIMIT SWITCHES

The lift comes equipped with various preset limit switches for monitoring the safety functions and final positions. The control functions of the limit switches are described below. Figure 10 shows the location and description of the limit switches on the lift. The connection diagram for the control and safety switches is illustrated in the Index (**Section 2**).

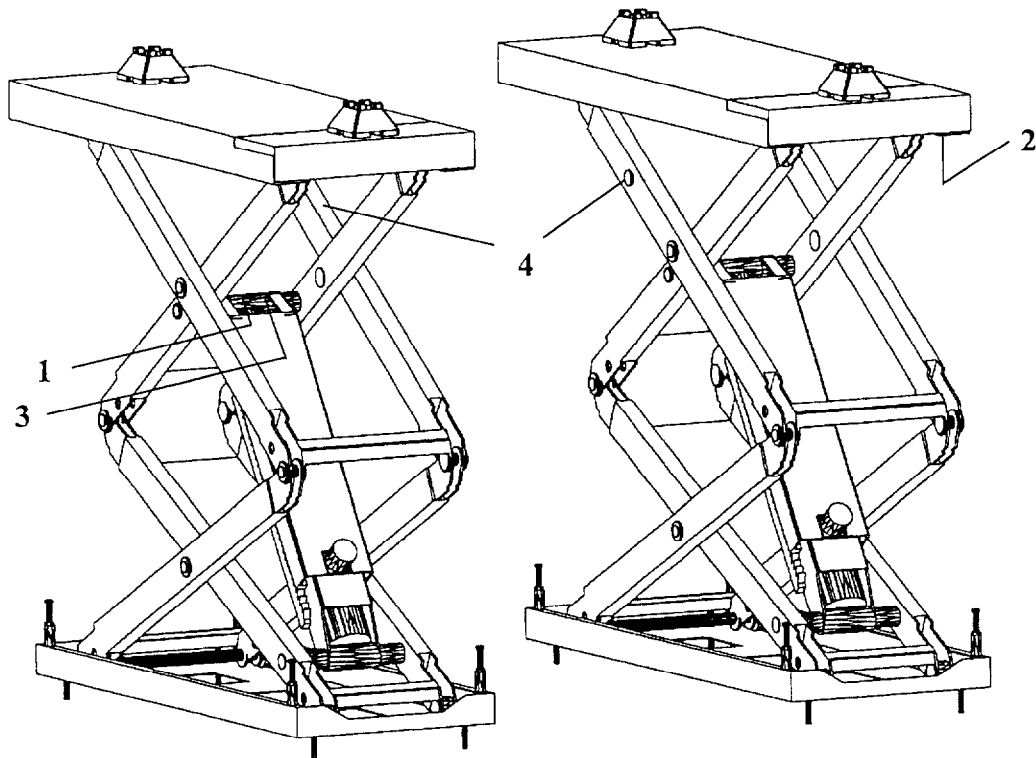

Figure 10 - Designation of the limit switches

1. Final bottom position switch. This controls the vertical leveling of the runways when lowering, since the photocell is not active over the last 15 $\frac{3}{4}$ " (400mm) where the light beam is interrupted by the scissors.
2. Switch for autoleveling of the runways when lowering.
3. Final top position switch.
4. Photocell with refracting mirror to control the leveling of the runways

Procedure for checking the limit switches

When the supply and control lines are connected and the anchor bolts are fitted, check the limit switches for proper performance.

1. To check the limit switches, move the lift to the corresponding control positions of the limit switches in order to check their correct response.
2. If the switch settings are incorrect, the limit switches should be re-adjusted accordingly.

6 OPERATION OF THE LIFT

6.1 INITIAL OPERATION

- **Initial operation may only be carried out by an expert.**
- Check the electrical connections and control leads for proper installation.
 - Visual inspection
- Ensure that the base frames are properly anchored to the ground.
- Lubricate the tracks of the rollers in the deck and base frames with commercial lubricating grease.
- Check vertical levels of the runways and ensure that they are parallel.
- Check that all the hydraulic connections are correct and that there is no leakage.
 - Visual inspection
- Raise the lift. Check that the hydraulic system has been bled correctly, and if necessary repeat the bleeding procedure.
- The lift has to raise and lower smoothly and free from jerking over the entire travel.
- Check the controls for proper allocation and performance.
- Check the gear racks for proper engagement by raising the runways and settling the gear racks at several levels.
- Check the photocell monitoring device (Figure 10, Item 4) for correct performance. This is done using a sheet of cardboard or paper (approx. 4" x 4" (100 x 100mm) see Figure 11, Item 8), with a hole of approx. 1" (25mm) in diameter (Figure 11, Item 9). Raise the lift until the photocell and the reflector are no longer blocked by the scissor arms. In this position, place the hole of the sheet of cardboard or paper over the centre of the reflector (Figure 11, Item 11).
 - If the lift does not travel up when the UP key is pressed, the light beam transmitted by the photocell does not coincide with the free zone of the reflector.
 - Correct the alignment of the lift so that the light beam coincides with the free zone of the reflector.
 - Repeat this check in the middle of the travel range (approximately) and in the final top position.

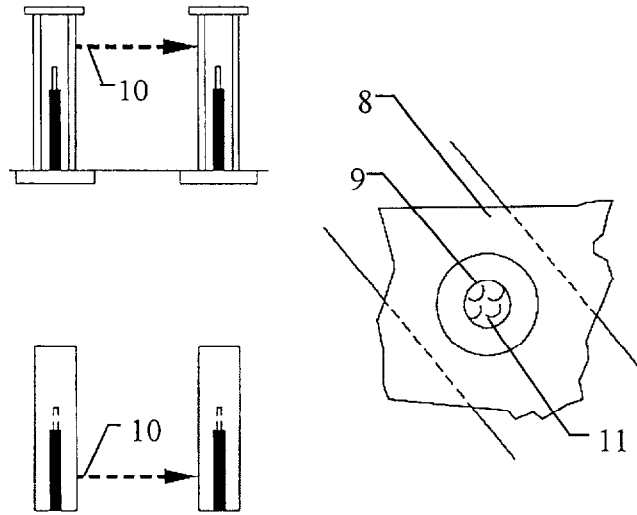

Figure 11 - Photocell Test

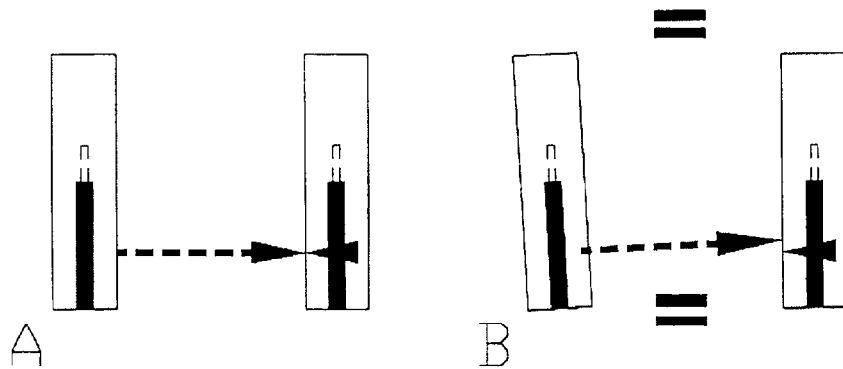
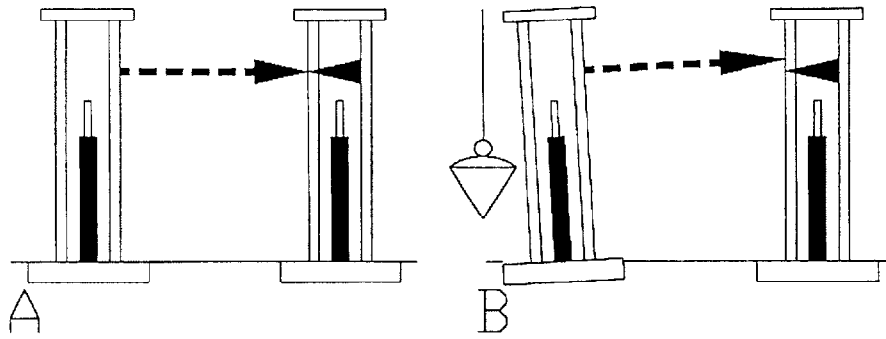

Figure 12- Function check of the photocell monitoring device - examples of incorrect positioning of the runways. A - Correct alignment. B - Examples of misalignment where correction is required

- Bleed the manual pump for emergency lowering: open the vent screw (Figure 13, Item 9) and press the UP key until the hydraulic oil emerges at the vent screw. Now close the vent screw.
- Position and secure the covers for all lines from the lift.
- Check that the cover panels of the control desk are correctly fitted
 - Visual inspection

The lift is now operational.

NOTE: During the initial operating period, disturbing noises may occur. These are usually a result of:

- New sealings on the hydraulic cylinders
- Air in the hydraulic system
- Rubbing at various contact points of the axle bearings or roller tracks.

If these noises do not disappear after the initial period, check their cause and remedy the problem accordingly.

6.2 BEHAVIOUR AND USE DURING OPERATION

- The safety devices must not be manipulated, made inoperative or removed.
- Only properly trained and authorized personnel should be allowed to operate the lift.
- The rated load capacity of 7000lbs. (3175 kg) on the lift **must never be exceeded** (take into account any additional load in or on the vehicle to be lifted).
- The operator must observe both the runways and the vehicle when lifting or lowering.
- While lifting or lowering, it is dangerous to stay under the runways (working area).
- Climbing the raised vehicle or the runways is strictly forbidden.
- The operator should avoid keeping objects scattered on the ground that may interfere with the lowering of the runways to the final bottom position.
- In case of trouble, press the EMERGENCY key. An expert must always carry out inspection and resetting of the lift.
- Before carrying out any maintenance on the lift, disconnect the power supply and close the main switch in order to prevent unauthorized persons from switching the power on.

6.3 LIFTING AND LOWERING

- Before driving a vehicle on or off the lift, ensure that the lift is at the final bottom position.
- Drive the vehicle slowly onto the runways until all wheels are fully accommodated on the runways.
- Prevent vehicles from rolling off the runways. All safety chocks have to be provided and in working order.
- Press the UP key (Figure 7, Item 5), to lift the vehicle to the required level.
- At this level, check that the vehicle is correctly accommodated.
- Now raise the vehicle to the required working height.
- Press the safety key with the double function to settle the gear rack (Figure 7, Item 2).
- Press the DOWN key to lower the runways. When the DOWN key is pressed, the runways first move upward to disengage the gear racks. The lowering motion stops at a height of 15 ¾" (400mm) above the bottom position at which point the operator must make sure that neither persons nor objects are within the working area. If the area is clear, the safety key (Figure 7, Item 2) can be pressed and the lift will be lowered to the final bottom position. When the safety key is pressed, a beeping sound can be heard over the entire travel.
- Before driving the vehicle out of the lift area, remove the rubber pads.

7 RESITING

To resit the lift, demount and re-install it on the new site as described in this manual.

An expert must carry out initial operation and safety inspection of the resited lift.

8 MAINTENANCE

Regular maintenance in line with the specifications is the basis for proper and reliable performance of the lift. Failure to carry out maintenance may impair the performance and reliability of the lift representing a risk to both personnel and the vehicle.

- Before carrying out any maintenance on the lift, disconnect the power supply and close the main switch to prevent unauthorized persons from switching it on.
- The lift has to be cleaned at least once a month. Do not use hoses, steam jets or harsh detergents.

Note: Immediately wipe away any spilt brake fluid as it will attack and damage the protective coating of the lift.

- It is particularly important to ensure that the piston rods of the hydraulic cylinders are always clean and undamaged. Damage to the pistons may result in leaking around the seals and malfunctioning of the lift. The piston rods are wear-resistant, thus, any damage to their surface is always due to the use of force or improper maintenance.

The following steps have to be performed at regular intervals, depending on the frequency of use of the lift:

- Check the hydraulic lines and connections for leakage and mechanical damage. The hydraulic lines must be replaced at the prescribed intervals.
- Check the pneumatic lines and connections for leakage and mechanical damage.
- Lubricate the tracks of the rollers on the deck and baseframe using a commercial lubricating grease.
- Change the hydraulic fluid every 5 years. Used oil must be disposed of in accordance with local regulations.
- Check all the safety devices for proper performance.

Defective parts must be replaced only by an expert

If these procedures are not followed and the user replaces any parts or assemblies that are important for the safety of the lift, vehicle and/or personnel, the user must ensure that the lift is approved and reset into operation by an expert.

9 TROUBLESHOOTING

Before carrying out any maintenance on the lift, disconnect the power supply, and close the main switch in order to prevent unauthorized persons from switching on.

9.1 PROBLEMS, CAUSES AND REMEDIES

A list of possible problems and remedies is shown below.

PROBLEM	CAUSE	REMEDY
The lift does not work.	<ul style="list-style-type: none"> - The main switch is not turned on. - Power failure. - The safety device is defective. - The electrical lines are interrupted. 	<ul style="list-style-type: none"> - Check all the associated components.
The lift does not raise	<ul style="list-style-type: none"> - The direction of rotation of the motor is not correct. - Insufficient oil in the hydraulic unit. - The UP key is defective. - The micro device is defective. - The lowering valve does not close. - The filter of the suction pump is dirty. 	<ul style="list-style-type: none"> - Interchange the two phases on the main switch. - Add hydraulic oil. - Check the UP key and the related line. - Check the micro device and the related line. - Check the lowering valve. - Check the filter and clean if necessary.
The lifting capacity is insufficient.	<ul style="list-style-type: none"> - The pressure valve is not set correctly. - The pump is defective. 	<ul style="list-style-type: none"> - Adjust the pressure valve - Check the pump and replace if necessary
The runway does not lower completely.	<ul style="list-style-type: none"> - The micro device is not set correctly or is defective. - The lowering valve is defective. 	<ul style="list-style-type: none"> - Check the micro device and bleed the hydraulic system. - Lower lift manually (see Emergency lowering).
The runways lower on their own.	<ul style="list-style-type: none"> - The synchronizing valve does not work correctly. - Leakage in the hydraulic system. 	<ul style="list-style-type: none"> - Check the valve. - Check the hydraulic system.
The lift does not lower when the DOWN is pressed.	<ul style="list-style-type: none"> - The photocell does not work properly. - The micro devices on the gear racks do not work properly. 	<ul style="list-style-type: none"> - Check all the associated components and replace if necessary.
The lift does not lower smoothly.	<ul style="list-style-type: none"> - Air in the hydraulic system - The lowering valve is defective. 	<ul style="list-style-type: none"> - Bleed the hydraulic system.
The gear racks do not engage or disengage.	<ul style="list-style-type: none"> - No compressed air. - No oil. 	<ul style="list-style-type: none"> - Check the pneumatic system. - Check the relative components. - Check the SAFETY - DOWN key.

9.2 EMERGENCY LOWERING OF THE LIFT

Manual lowering of the lift

- Open the front panel of the control desk, and press the valve A upwards using a thin screwdriver or a pin punch. At the same time, pump the manual pump (Figure 13, Item 1) until the lift is raised slightly (for bleeding of the manual pump, see Section 6.1), and the gear racks disengage.
- Fold back the upper gear rack from the lower rack and prevent them from re-engaging e.g. using a strip of wood.
- Unscrew the cap nut (Figure 13, Item 7) on the valve (Figure 13, Item 6). Release the lock nut from the adjusting screw from underneath and drive the screw in completely using a suitable socket screw wrench (hex. socket 3mm), the runways lower to the final bottom position.
- Unscrew the adjusting screw again, and then drive it in again until a slight resistance can be felt. Lock the adjusting screw with the lock nut and replace the cap nut.

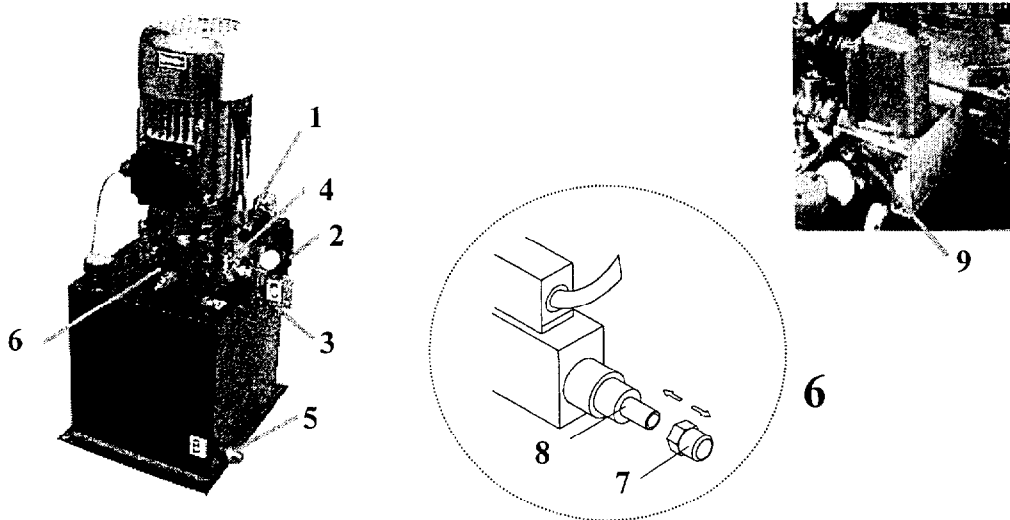

Figure 13 - Hydraulic unit with manual pump and lowering valves. To lower the lift in the event of a malfunction

1. Manual pump
2. Valve for level
3. Connection of hydraulic line C
4. Connection of hydraulic line A
5. Connection of hydraulic line B
6. Control valve
7. View 6, cap nut
8. View 6, adjusting screw for emergency lowering of pad plates
9. Vent screw (hexagon socket screw) for emergency lowering pump (Item 1).

10 TECHNICAL DATA

Capacity:	7000 lb.	3175 kg
Length of Runways:	60" (83" Extended)	1530 mm (2100mm Extended)
Overall Width:	74"	1880 mm
Width of Runways:	31½"	800 mm
Dimension of Control Desk:		
Width x Depth x Height	17 ¾" x 17 ¾" x 41 ½"	450 x 450 x 1050 mm
Maximum Raised Height:	69"	1753 mm
Collapsed Height:	0"	0 mm
Shipping Weight:	1543 lb.	700 kg
Motor	3.0 kW	
Power supply	230 V/1 Ph./60 Hz.	
Control Voltage	24 V	
Fuses:		
Main fusing	10 A	
Protection class	IP 55	
Hydraulic oil	ISO 32 (10 weight hydraulic oil)	
Hydraulic oil - quantity	5.3 Gal.	20 L
Max. service pressure	3481 psi	240 bar
Safety valve responds at	3481 psi	240 bar
Pneumatic line pressure	87-145 psi	6 - 10 bar
Lifting time	Approx. 45 sec.	
Lowering time	Approx. 45 sec.	
Noise level	70 dB (A)	

11 INDEX

11.1 HYDRAULIC SCHEMATIC

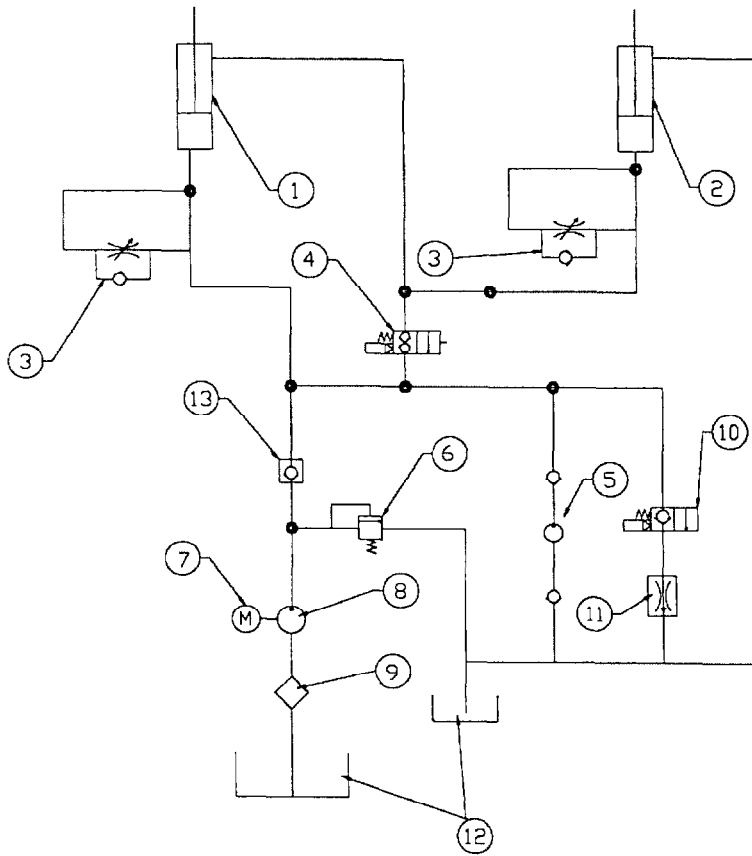

- 1. Cylinder, Runway P1
- 2. Cylinder, Runway P2
- 3. Safety Valve (lowering)
- 4. Leveling Valve
- 5. Manual Pump
- 6. Pressure Relief Valve
- 7. Electric Motor
- 8. Hydraulic Pump
- 9. Filter
- 10. Solenoid Valve DOWN
- 11. Control Valve DOWN
- 12. Oil Tank
- 13. One Way Valve

11.2 ELECTRICAL SCHEMATIC

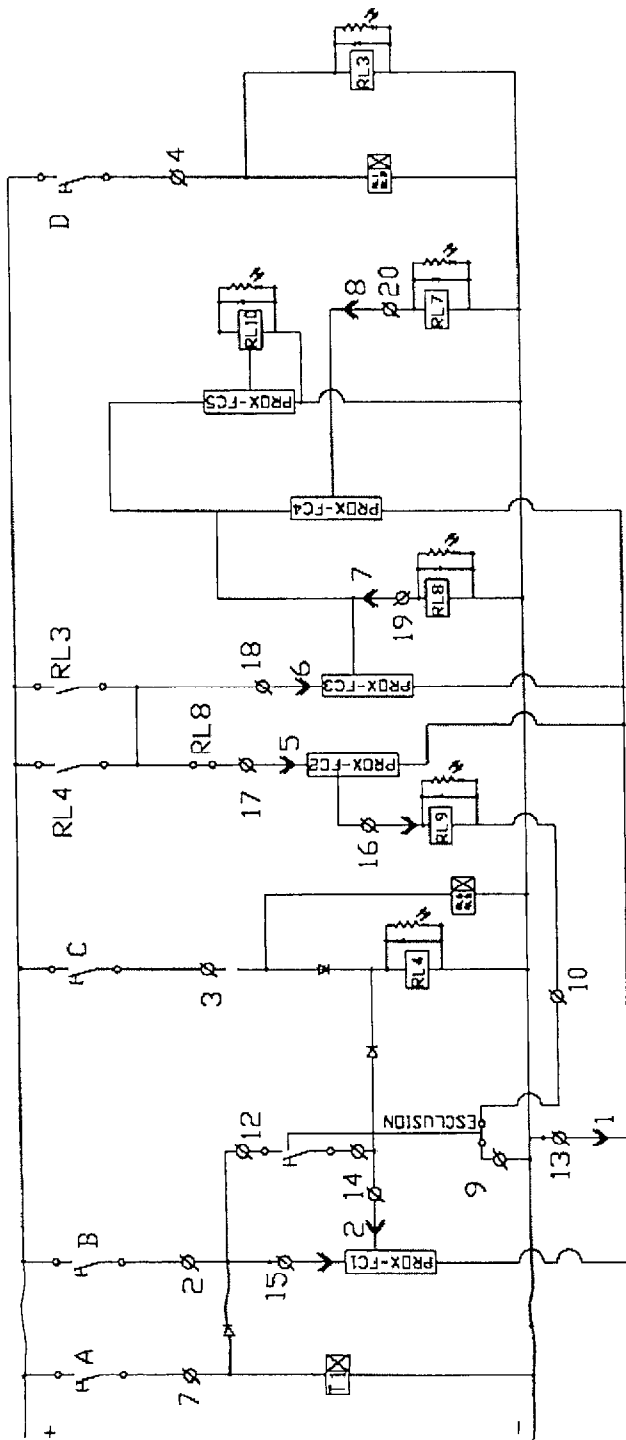

- A: Emergency
- B: UP
- C: DOWN 1
- D: DOWN 2
- FC1: L.S. Max. Height
- FC2: L.S. Photocell
- FC3: L.S. Level

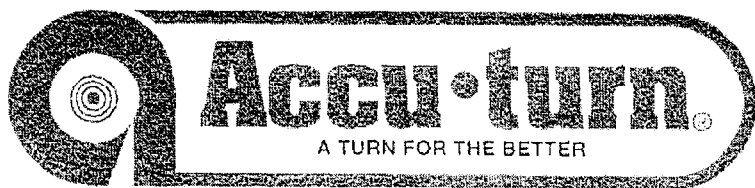

MODEL # AC35196FM

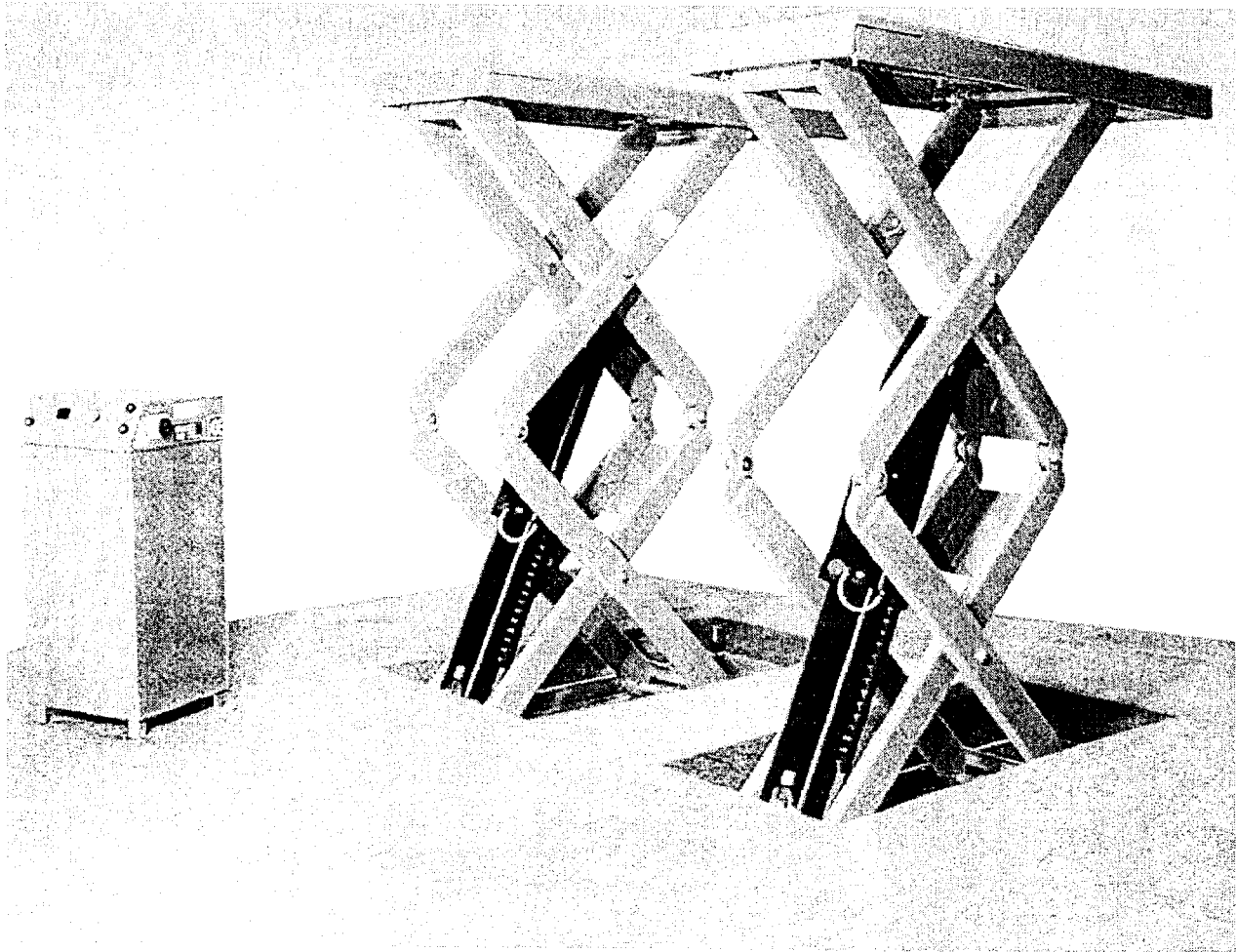

PARTS MANUAL

SAVE THESE INSTRUCTIONS
READ ALL INSTRUCTIONS
BEFORE USING LIFT

MAR 2000 6-2220



Accu International, Inc.

P.O. Box 15540 Richmond, VA 2327
804-798-8922

www.accu-turn.com 1-800-551-2228

12.1 LIFT ASSEMBLY PARTS LIST

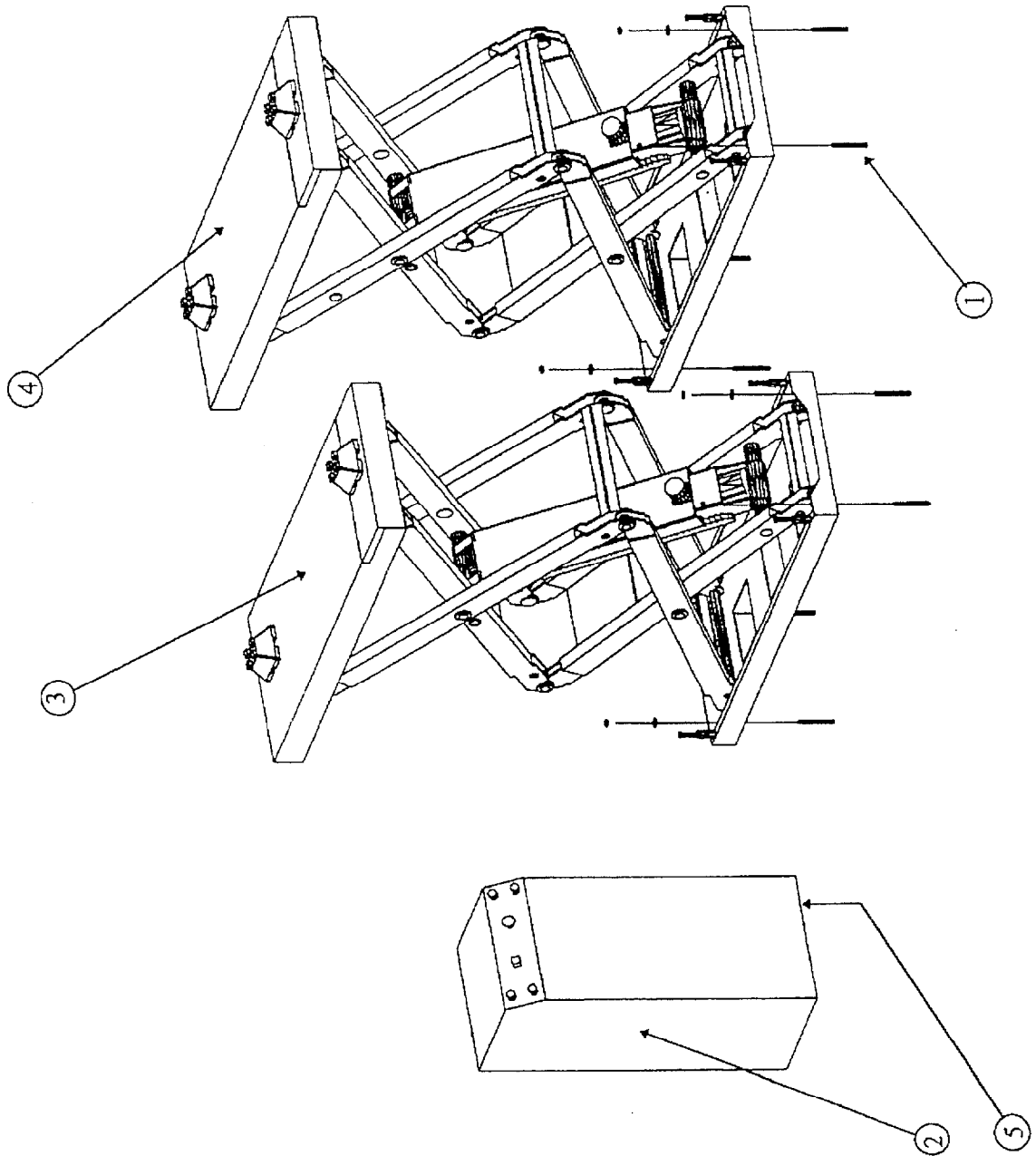

12.2 HYDRAULIC/AIR DIAGRAM

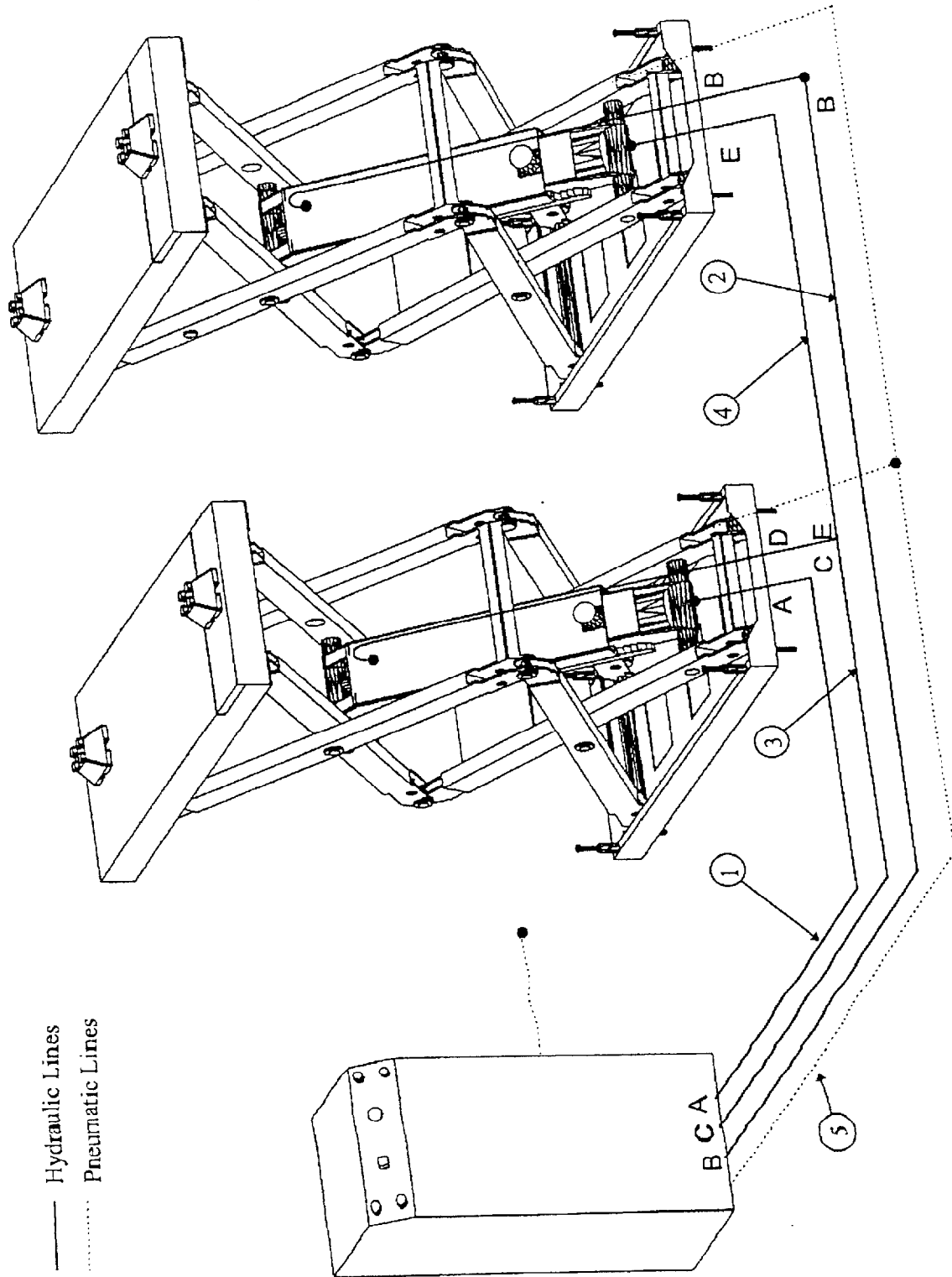

12.3 PARTS LIST

LIFT ASSEMBLY PARTS LIST

Item #	Qty.	Description	Part #
1	8	Wedge Anchor, 1/2" x 4 1/2" (c/w nuts & washers)	6-0140
2	1	Control Desk	4-0608
3	1	Left Side Deck Ass'y	4-0606
4	1	Right Side Deck Ass'y	4-0607
5	4	Wedge Anchor 3/8" x 2 1/2" (c/w nuts & washers)	6-1571

HYDRAULIC\AIR PARTS LIST

Item #	Qty.	Description	Part #
1	1	Hydraulic Hose "A"	2-1264
2	1	Hydraulic Hose "B"	2-1265
3	1	Hydraulic Hose "C"	2-1266
4	1	Hydraulic Hose "E"	2-1267
5	1	Pneumatic Line	6-1569