

INSTALLATION and OPERATION MANUAL

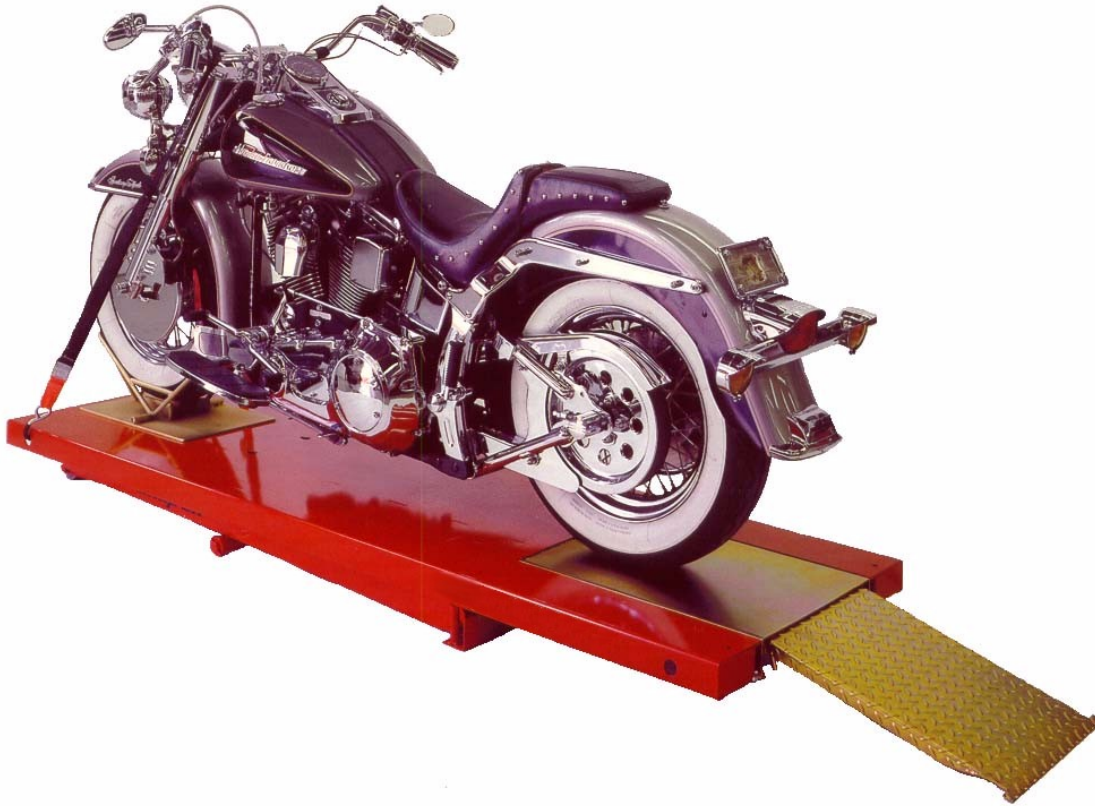

1.5K MOTORCYCLE LIFT AC319

**READ and SAVE THIS
INSTRUCTION MANUAL**



P.O. Box 15540 Richmond, VA 23227
804-798-8922
www.accu-turn.com 1-800-551-2228

MAR. 2004 6-2968

TABLE OF CONTENTS

ITEM	PAGE
1. SAFETY AND OPERATING INSTRUCTIONS.....	1
2. GENERAL SPECIFICATIONS	3
3. CONTENTS.....	4
4. INSTALLATION REQUIREMENTS AND TOOLS.....	4
5. INSTALLATION INSTRUCTIONS.....	5
5.1 UNPACKING PROCEDURE	5
5.2 HYDRAULIC SYSTEM INSTALLATION	5
5.3 HYDRAULIC SYSTEM BLEEDING PROCEDURE.....	5
5.4 ANCHORING PROCEDURE	6
6. POSITIONING INSTRUCTIONS	6
7. OPERATING INSTRUCTIONS	7
8. RECOMMENDED MAINTENANCE.....	7
8.1 DAILY MAINTENANCE.....	7
8.2 MONTHLY MAINTENANCE	7
9. PARTS MANUAL.....	8
9.1 MAIN FRAME ASSEMBLY	9
9.2 MAIN FRAME ASSEMBLY - PARTS LIST.....	10
9.3 HYDRAULIC CYLINDER ASSEMBLY	11
9.4 HYDRAULIC CYLINDER ASSEMBLY - PARTS LIST.....	12
9.5 PULL-OUT PAN ASSEMBLY	12
9.6 PULL-OUT PAN ASSEMBLY - PARTS LIST.....	12
9.7 POWER PACK STAND	13
9.8 POWER PACK STAND - PARTS LIST.....	13
9.9 POWER PACK: #6-2249 (AB-1425) 115-230V/1PH/60Hz.....	14
9.10 POWER PACK PARTS LIST: #6-2249 (AB-1425) 115-230V/1PH/60Hz	15

1. SAFETY AND OPERATING INSTRUCTIONS

1. Read all safety and operating instructions before using the lift.
2. Inspect the lift daily. Do not operate the lift if it is damaged, malfunctioning, or if problems have been encountered.
3. Never attempt to overload the lift. The manufacturer's rated capacity is shown on the serial number tag, located on the scissor assembly.
4. **DO NOT OVERRIDE** the automatic safety devices incorporated into the lift.
5. Only trained and authorized personnel should operate the lift. Do not allow customers or bystanders to operate the lift or be in the lift area. Operators and bystanders must stay completely clear of the lift when raising and lowering.
6. The lift must only be operated on level and smooth floors.
7. Never drive a vehicle into position on the lift. All vehicles must be pushed onto the lift. Before rolling a vehicle on or off the lift, make certain that the lift has been completely lowered.

NOTE: When positioning a vehicle on the lift, take time to center the load front-to-rear and side-to-side. The removal or installation of some vehicle parts may cause a critical shift in the center of gravity and may cause the vehicle to become unstable.

8. **All vehicles must be securely fastened to the lift using tie down straps.**
9. To raise the lift, press the "UP" button on the front face of the powerpack motor. To lower, raise the lift until the automatic safety release device trips, then press down on the control lever.
10. Do all work while the lift is on its mechanical safety lock.
11. Always keep the lift area free of obstruction and debris. Grease and oil spills should always be cleaned up immediately.
12. Never raise the lift with a passenger onboard. Do not climb onto the lift or vehicle when it is in the raised position.
13. Retract the approach ramp after the lift has been raised to avoid any sharp, protruding objects.
14. Avoid excessive rocking of the lift while it is in the raised position.
15. Before lowering the lift, check the area for obstructions.
16. Care must be taken as burns can occur from touching hot parts.

17. Do not operate equipment with a damaged cord, or if the equipment has been dropped or damaged – until a qualified serviceman has examined it.
18. Do not let cord hang over table, bench or counter or come into contact with hot manifolds or moving fan blades.
19. If an extension cord is necessary, a cord with a current rating of two times or more than that of the equipment should be used. Cords rated for less current than the equipment may overheat. Care must be taken to arrange the cord so that it will not be tripped over, or pulled.
20. Always unplug equipment from electrical outlet when not in use. Never use the cord to pull the plug from the outlet. Grasp and pull plug to disconnect.

NOTE: DO NOT ATTEMPT TO OPERATE THE LIFT IF ANY PART IS NOT WORKING PROPERLY OR IF YOU HAVE NOT READ THE COMPLETE OPERATING INSTRUCTION MANUAL.

2. GENERAL SPECIFICATIONS

Capacity:
 Overall Width:
 Overall Width (with Opt. Side Extension Kit):
 Overall Width (with Opt. Portable Kit):
 Overall Length:
 Overall Length (with Opt. Side Extension Kit):
 Overall Length (with Opt. Front Extension Kit):
 Down Position Height:
 Maximum Lifting Height:
 Shipping Weight:
 Power Requirement
 Lifting Time:

1500lbs.	680kg
27"	686mm
51"	1295mm
48"	1219mm
89"	2261mm
112"	2845mm
101"	2565mm
6"	152mm
48"	1219mm
250lbs.	113kg
115V, 20Amp, 1Ph., 60Hz	
15 sec.	

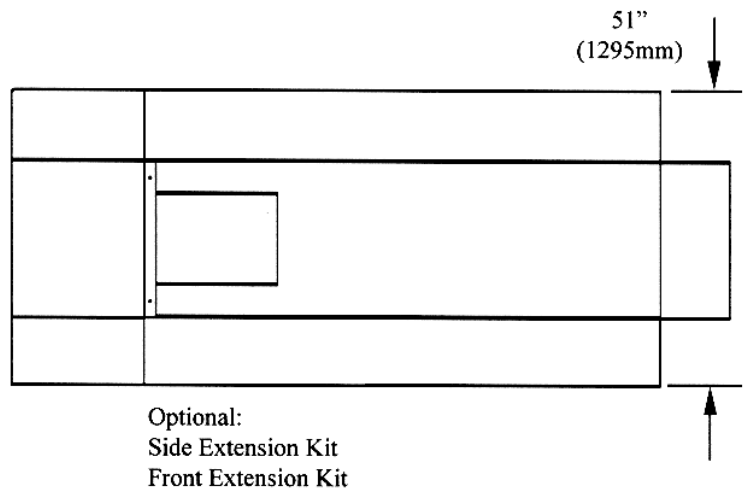
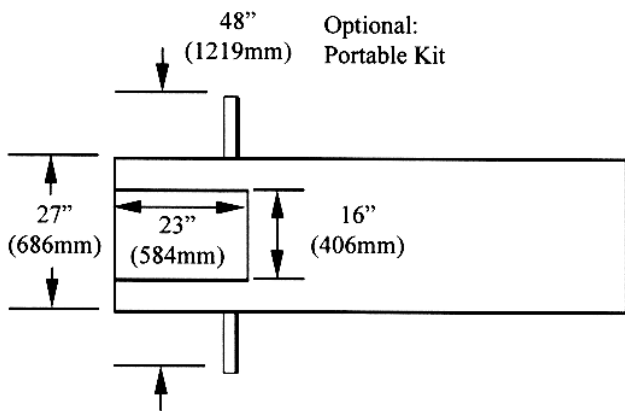
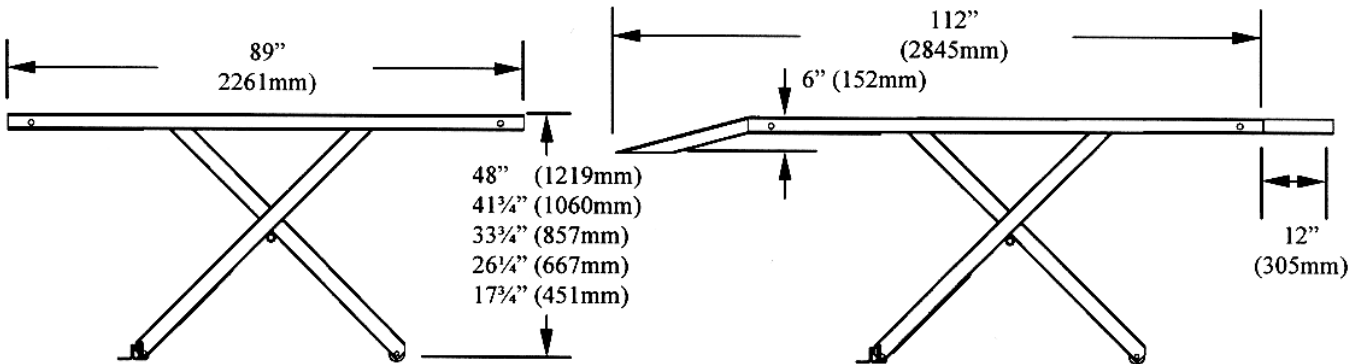

3. CONTENTS

The complete lift is contained in two (2) packages:

1. The **main structural components** are packed on a shipping skid.
2. The remaining parts are packed in an **accessory box**.

Main Structural Components include:

- 1pc. Deck-Scissor Assembly (including Pull-Out Pan and Approach Ramp)

Accessory Box Contents:

- 1pc. Power Pack Stand (with Power Pack)
1pc. "Posi-Grip" Wheel Locator
1pc. 12' Hydraulic Hose
1pc. Owner's Manual
2pc. Wedge Anchor, 1/2" DIA x 4 1/2" LG. (c/w nuts and washers)
2pc. Carriage Bolt, 1/2" DIA x 5" LG.
4pc. Hex Nut, 1/2" DIA

4. INSTALLATION REQUIREMENTS AND TOOLS

NOTE: Lifts should only be installed on "level" concrete floors, with a minimum thickness of five (5) inches or 130mm. Concrete must have a minimum strength of 4000psi or 30 MPa and should be aged thirty (30) days prior to installation. Please consult the architect, contractor or engineer if doubt exists as to the strength and feasibility of the floor to enable proper lift installation and operation

Tools Required:

1. 1/2" wrench
2. 9/16" wrench
3. 3/4" wrench
4. 5/16" wrench
5. Rotary Hammer Drill
6. 1/2" Diameter Masonry Drill Bit

5. INSTALLATION INSTRUCTIONS

5.1 UNPACKING PROCEDURE

Remove the metal strapping from the main structure package and slide the lift off the shipping skid. Open the accessory box and check the contents of the box.

NOTE: The Power Pack is already installed on the Power Pack Stand

5.2 HYDRAULIC SYSTEM INSTALLATION

1. Add 3 litres of ISO 32 (10 Hydraulic Weight) hydraulic oil to the power pack.
2. Reinstall the filler breather cap onto the power pack.
3. Plug the power pack utility cord into an approved 115 Volt outlet.
4. Install the 1/4" JIC female end of the 12' long hydraulic hose to the outlet fitting on the hydraulic cylinder.
5. Connect the other end (3/8" JIC female) of the 12' long hydraulic hose to the 90° fitting on the power pack.

5.3 HYDRAULIC SYSTEM BLEEDING PROCEDURE

NOTE: Make certain lift area is clear from debris and any obstructions.

1. Press the "UP" button on the power pack and raise the lift a few inches off the floor. Check for any hydraulic leaks.
2. Lower the lift by pushing the down control lever on the power pack.
3. Lower the lift completely.
4. Repeat this procedure to bleed the hydraulic cylinder.
5. Raise the lift to engage the mechanical safety lock.
6. Lower the lift onto the safety.
7. Raise the lift a few inches to automatically disengage the mechanical safety.
8. Lower the lift completely.
9. Cycle the lift up and down completely a few times.
10. The hydraulic system is a self bleeding system.

5.4 ANCHORING PROCEDURE

NOTE: The lift must always be anchored to a level and smooth floor. If the lift is to be operated in different locations, a portable kit, that includes a tow cart and outrigger, must be used. **Note: When the tow cart is used, the lift must be in the fully down position and vehicles must be removed from the lift.**

1. Position the lift in the center of the work area or bay to ensure adequate clearance around the lift. To move the lift, raise the rear end off the ground and roll it into position. Place the power pack stand in a suitable area.
2. Raise the lift to its full height and lower it onto its safety.
3. Using a rotary hammer with a ½” masonry drill bit, drill two holes in the floor through the holes in the base angle weldment (see parts list).
4. Install the anchor bolts and torque them to 150 ft·lb.
5. Install the ½”DIA x 5” carriage bolts under the rear of the deck (left and right of the pull-out pan). Adjust the bolts so that the deck is level when fully collapsed.

6. POSITIONING INSTRUCTIONS

NOTE: Please review the safety instructions and the safety card attached to the stand. Inspect the lift for mechanical fitness before using.

1. Plug the electric utility cord into an approved 115V outlet.
2. Pull out the approach ramp from the pull-out pan and lower onto the ground.
3. Roll the vehicle onto the lift. **Vehicles must never be driven onto the lift.**
4. Using tie down straps, secure the vehicle to the lift.

NOTE: When positioning the motorcycle on the lift, take time to equalize the load front-to-rear and side-to-side. Some vehicles may require additional assistance when loading and unloading. Always restrain vehicle to lift using proper tie down straps.

7. OPERATING INSTRUCTIONS

1. Raise the lift by pressing the “UP” button on the front face of the Power Pack Motor.
2. Continue raising the lift until the mechanical safety “CLICKS” into position. Always lower the lift to fully engage the mechanical safety lock.

NOTE: All lifts are equipped with dual safety locking devices, an automatic mechanical safety bar, and a flow control to protect against hydraulic failure.

3. To disengage the mechanical safety and lower the lift, press the “UP” button on the Power Pack Motor to raise the lift off of the mechanical safety. Continue raising the lift until the automatic mechanical safety release device trips.
4. Lower the lift fully to the down position.
5. Roll the vehicle straight back off the lift.

8. RECOMMENDED MAINTENANCE

8.1 DAILY MAINTENANCE

1. Check the general operation of the lift.
2. Check the operation of the automatic mechanical safety lock, both engaging and disengaging.
3. Check the floor condition in the roller area for cracks and debris.
4. Check the position of the hydraulic hose, ensure that a motorcycle positioned on the lift or the lift itself will not damage the hose.
5. Check the condition of the electrical cord before plugging the power pack into an approved 115V power supply.

8.2 MONTHLY MAINTENANCE

1. Check all hydraulic hoses, fittings and cylinder for leaks.
2. Check the level of oil in the power pack reservoir when the lift is in the lowered position. Add more hydraulic oil (ISO 32) if required.
3. Check and grease all hinge points.

4. Check and lubricate the automatic safety release device.
5. Inspect the 115V plug end and cable.
6. Inspect the main structure of the power pack stand.
7. Inspect the lift area for debris and concrete condition.

8.3 MAIN FRAME ASSEMBLY

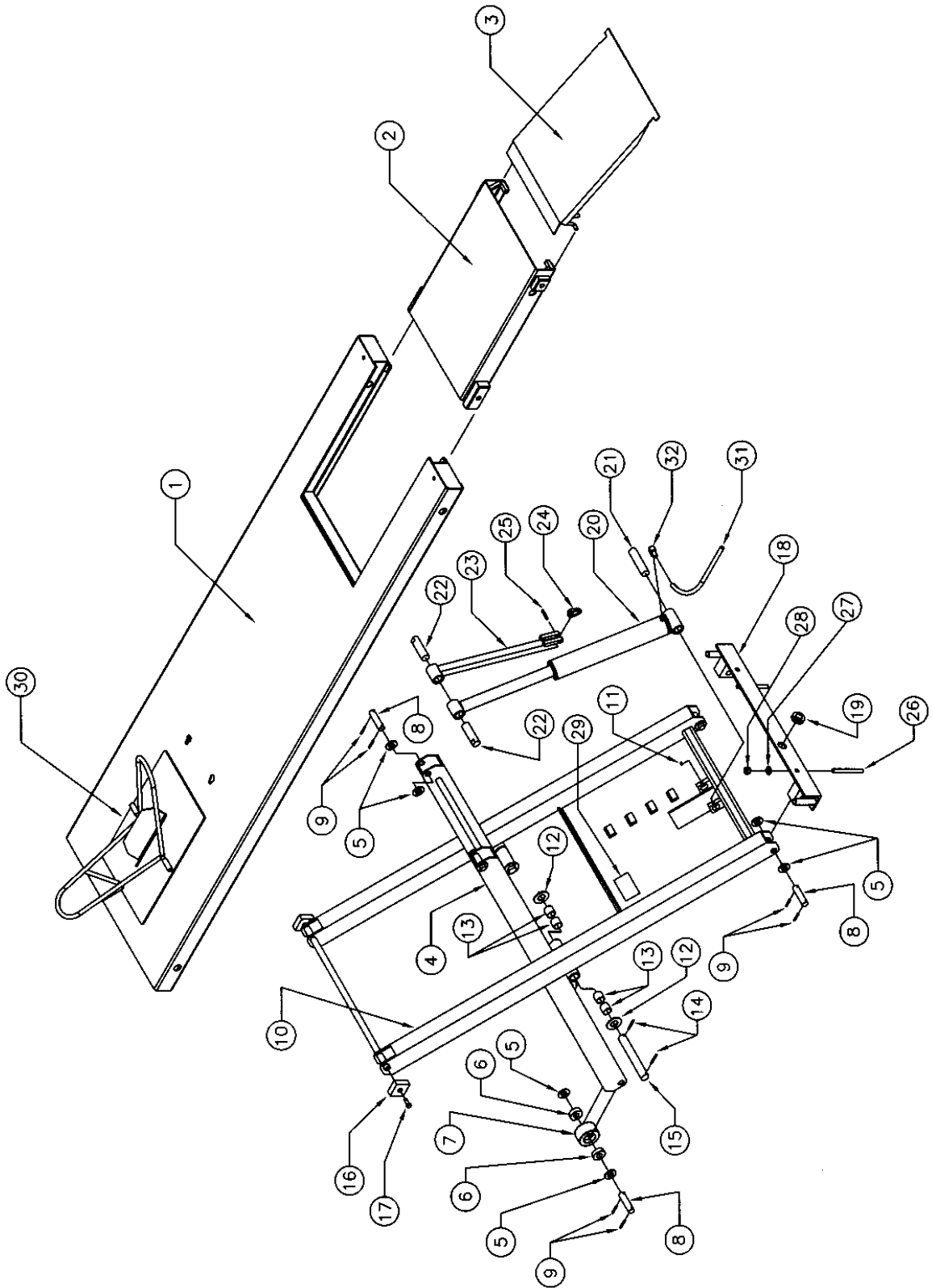

8.4 MAIN FRAME ASSEMBLY - PARTS LIST

ITEM NO.	QTY.	DESCRIPTION	PART NO.
1	1	DECK WELDMENT	4-0615
2	1	PULL-OUT PAN ASSEMBLY	3-0668
3	1	PULL-OUT PAN RAMP WELDMENT	3-0672
4	1	INNER SCISSOR WELDMENT	4-0618
5	12	FLAT WASHER, 3/4" SAE	6-0738
6	4	BRONZE BUSHING	6-1687
7	2	ROLLER CASTING	1-1664
8	6	ROLLER PIN	1-1665
9	12	SPRING PIN, 3/16" X 1 1/4" LG.	6-0749
10	1	OUTER SCISSOR WELDMENT	4-0619
11	4	SET SCREW, 1/4"-20UNC X 3/8" LG.	6-0580
12	4	THRUST WASHER, 1" SAE	6-0328
13	8	BUSHING, 1"ID X 1 1/8"OD X 1"LG	6-1620
14	4	SPRING PIN, 3/16" X 1 1/2" LG.	6-1682
15	2	SCISSOR PIN	1-1660
16	2	DECK GLIDE BLOCKS	1-1673
17	2	SHOULDER BOLT, 3/8" X 3/4" LG.	6-0729
18	1	LOWER BASE ANGLE WELDMENT	3-0660
19	1	RUBBER GROMMET	6-0670
20	1	CYLINDER ASSEMBLY	3-0667
21	1	CYLINDER AXLE (LOWER)	2-1330
22	2	CYLINDER AXLE (UPPER)	2-1329
23	1	BRAKE LEG WELDMENT	3-0663
24	1	OVERRIDE PLATE (NYLON)	2-0819
25	1	SPRING PIN, 1/4" X 1 1/2" LG.	6-0745
26	2	ANCHOR BOLTS, 1/2"-13UNC X 4 1/2"LG	6-0140
27	2	FLAT WASHER, 1/2" SAE	6-0248
28	2	HEX NUT, 1/2"-13 UNC	6-0035
29	1	SERIAL TAG	6-1663
30	1	"POSI-GRIP" WHEEL LOCATOR	3-0692
31	1	HYDRAULIC HOSE, 12FT LONG	6-2319
32	1	FLOW CONTROL 0.75MM	6-1638

8.5 HYDRAULIC CYLINDER ASSEMBLY

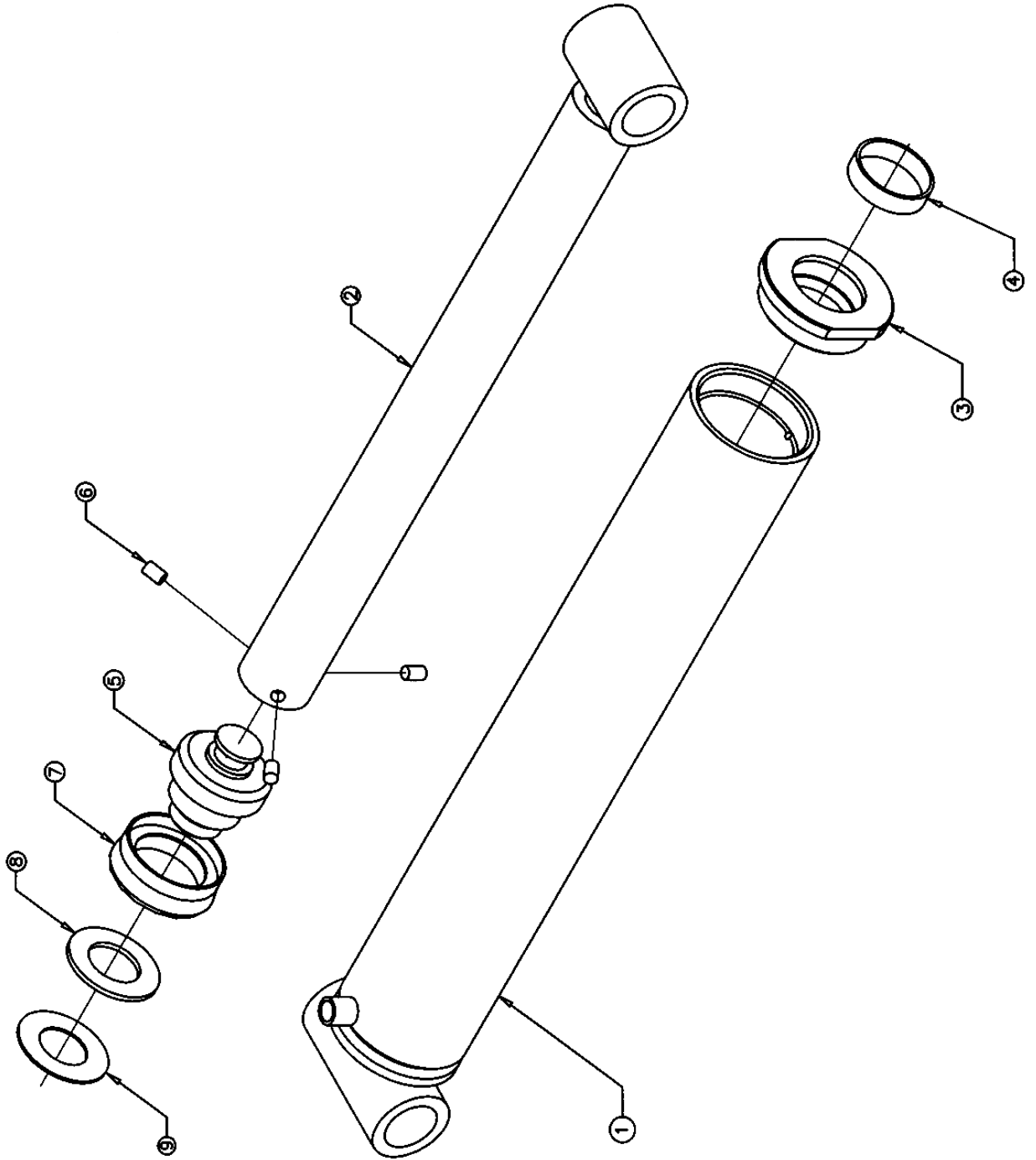

8.6 HYDRAULIC CYLINDER ASSEMBLY - PARTS LIST

ITEM NO.	QTY.	DESCRIPTION	PART NO.
1	1	CYLINDER TUBE WELDMENT	2-1323
2	1	PISTON ROD WELDMENT	2-1324
3	1	GLAND	1-1669
4	1	WEAR RING 1 3/8"ID x 1 1/2"OD x 3/8"LG	6-1679
5	1	PISTON (2" BORE)	2-0511
6	3	ALLEN HD SET SCREW 1/4"-20UNC x 3/8"LG	6-0580
7	1	SEAL AND WEAR RING	6-0579
8	1	KEEPER WASHER	1-0725
9	1	EXTERNAL SNAP RING	6-0581

8.7 PULL-OUT PAN ASSEMBLY

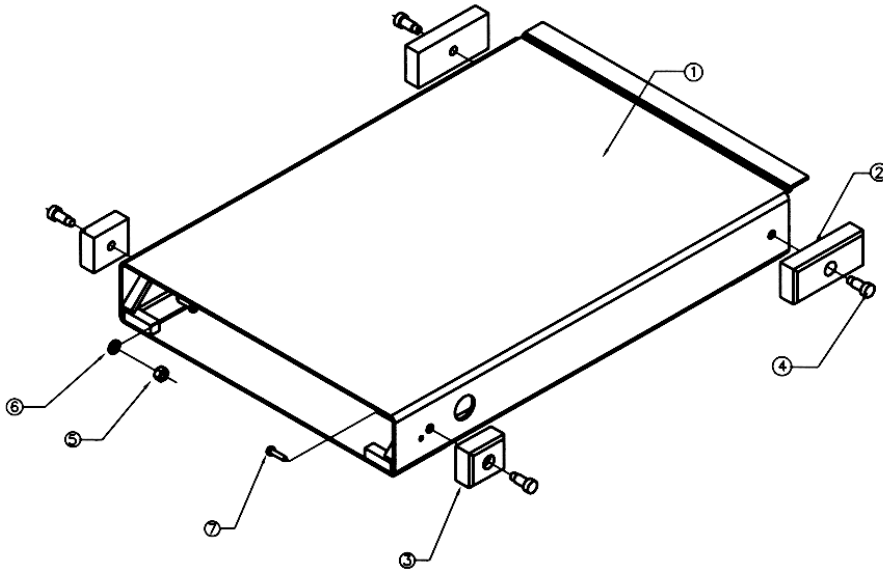

8.8 PULL-OUT PAN ASSEMBLY - PARTS LIST

ITEM NO.	QTY.	DESCRIPTION	PART NO.
1	1	PULL-OUT PAN WELDMENT	2-1326
2	2	PULL-OUT PAN GLIDE BLOCKS (FRONT)	1-1674
3	2	PULL-OUT PAN GLIDE BLOCKS (REAR)	1-1675
4	4	SHOULDER BOLT 3/8" x 5/8"LG	6-0069
5	4	HEX NUT 5/16"	6-0294
6	4	LOCKWASHER 5/16"	6-0674
7	4	#10 SELF TAPPING SCREW, 3/4"LG	6-0297

8.9 POWER PACK STAND

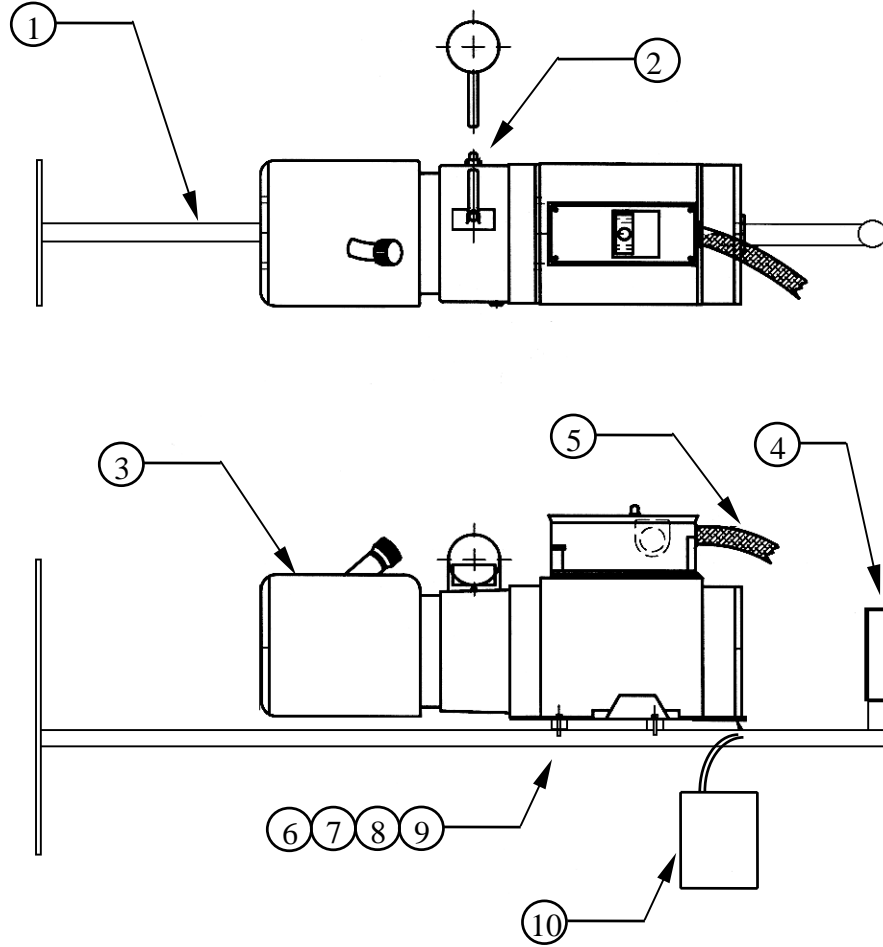

8.10 POWER PACK STAND - PARTS LIST

ITEM NO.	QTY.	DESCRIPTION	PART NO.
1	1	STAND WELDING	3-0669
2	1	ELBOW 90° ¼" JIC TO 9/16" SAE	6-1093
3	1	POWER PACK 115V ¾ HP*	6-2249
4	1	GRIP HANDLE	6-0758
5	1	PLUG	6-1488
6	4	HEX BOLT 5/16"-18UNC X ¾" LG.	6-0423
7	4	LOCKWASHER 5/16" I.D.	6-0674
8	4	FLAT WASHER 5/16" I.D.	6-0295
9	4	HEX NUT 5/16"-18UNC	6-0294
10	1	SAFETY PLACARD	6-1831

* SEE NEXT PAGE FOR THE POWER PACK

8.11 POWER PACK: #6-2249 (AB-1425) 115-230V/1PH/60Hz

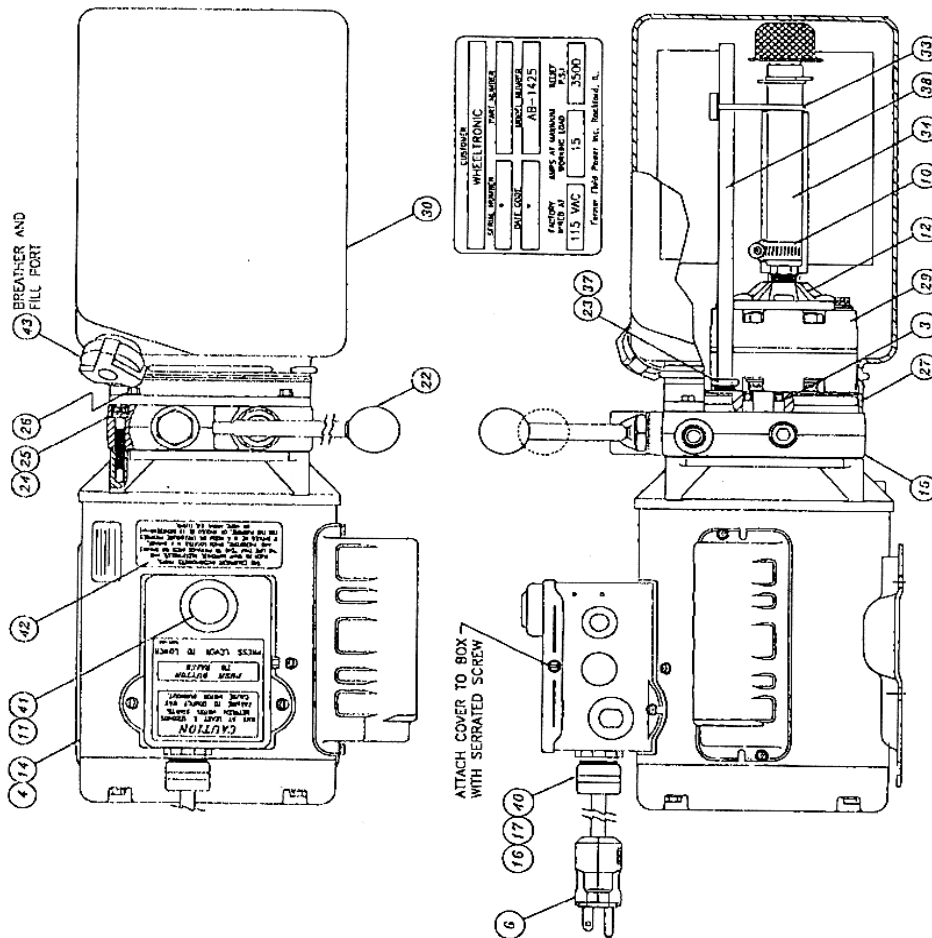
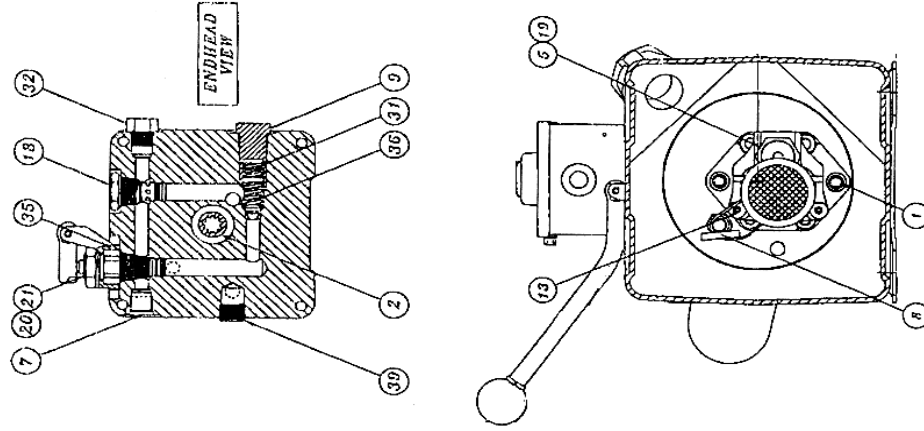

9.10 POWER PACK PARTS LIST: #6-2249 (AB-1425) 115-230V/1PH/60Hz

ITEM	QTY.	DESCRIPTION	PART #
1	2	BOLT 5/16"-24 x 2 3/4" TORX G8	6-2298
2	1	COUPLING SAE 9T-20/40 1.260"	6-0774
3	1	SEAL SHAFT 0.500" x 1.00" x 0.25"	6-2158
4	1	MOTOR AC PSC #613000 115/230 1 HP 1PH BLK	6-2299
5	1	WASHER 0.338" x 0.625" x 0.060" STEEL	6-2159
6	1	CORDSET 16/3 SJO 8FT 115V PLUG	6-2300
7	1	PACKAGE PLUG 9/16" SAE	6-2301
8	1	PLUMBING MAGNET	6-2162
9	1	RELIEF VALVE CAP ASSEMBLY	6-1089
10	1	PLUMBING CLAMP HOSE ADJ INLET	6-2166
11	2	ELECTRIC STAKON NUT	6-2302
12	1	COVER ASS'Y SUCTION	6-2165
13	2	SCREW TAPTITE M6x1.0 12MM TORX	6-2164
14	1	NAMEPLATE, SERIAL	
15	1	ENDHEAD UNIVERSAL AUTOHOIST	6-2155
16	1	ELECTRIC CORD GRIP 3/4" NPT	6-2303
17	1	ELECTRIC PIPENUT 3/4"	6-2304
18	1	VALVE CARTRIDGE CHECK	6-1087
19	1	VALVE LOAD DELAY	6-2305
20	1	NUT 3/4"-16 x 1" HEX x 0.250 STEEL	6-2167
21	1	WASHER 3/4" INT. TOOTH LOCK	6-2168
22	1	BRACKET HANDLE ASS'Y REL BLACK	6-0776
23	1	COMPRESSION TUBE NUT	6-2153
24	4	BOLT M6 x 1.0 35MM SOC HD	6-2169
25	4	WASHER 1/4" LOCK HI-COLLAR	6-2170
26	4	BOLT #12-24 x .50 HEX WSHRHD	6-1091
27	1	O-RING 2-348 BUNA	6-0875
28	1	COVER ASSY SUCTION	6-2165
29	1	PUMP ASS'Y 0.8 SHORT SPLINE	6-2306
30	1	TANK PLASTIC 6.7 CT 11.0" BLACK	6-2307
31	1	SPRING 0.480" x 0.063" x 0.42" COMP	6-2151
32	1	PLUMBING PLUG 5/16" SAE	6-2157
33	1	CABLE TIE 8" LONG WHITE	6-1846
34	1	PLUMBING ASS'Y INLET 6.61 (3)	6-2308
35	1	VALVE CARTRIDGE RELEASE MANUAL	6-0880
36	1	RELIEF ASSEMBLY FIXED 240 BAR	6-2309
37	1	COMPRESSION TUBE SLEEVE	6-2154
38	1	RETURN HOSE 3/8" OD x 10.0"	6-2310
39	1	PLUMBING PLUG 3/8"NPT	6-2161
40	2	ELECTRIC REDUCER WASHER	6-2311
41	1	WIRING ASSEMBLY AC 1PH FENNER	6-2156
42	1	LABEL INSTALLATION AUTOHOIST	6-2136
43	1	BREATHER CAP & BLADDER	6-1376

