

TWIN POST MODEL # AC9021

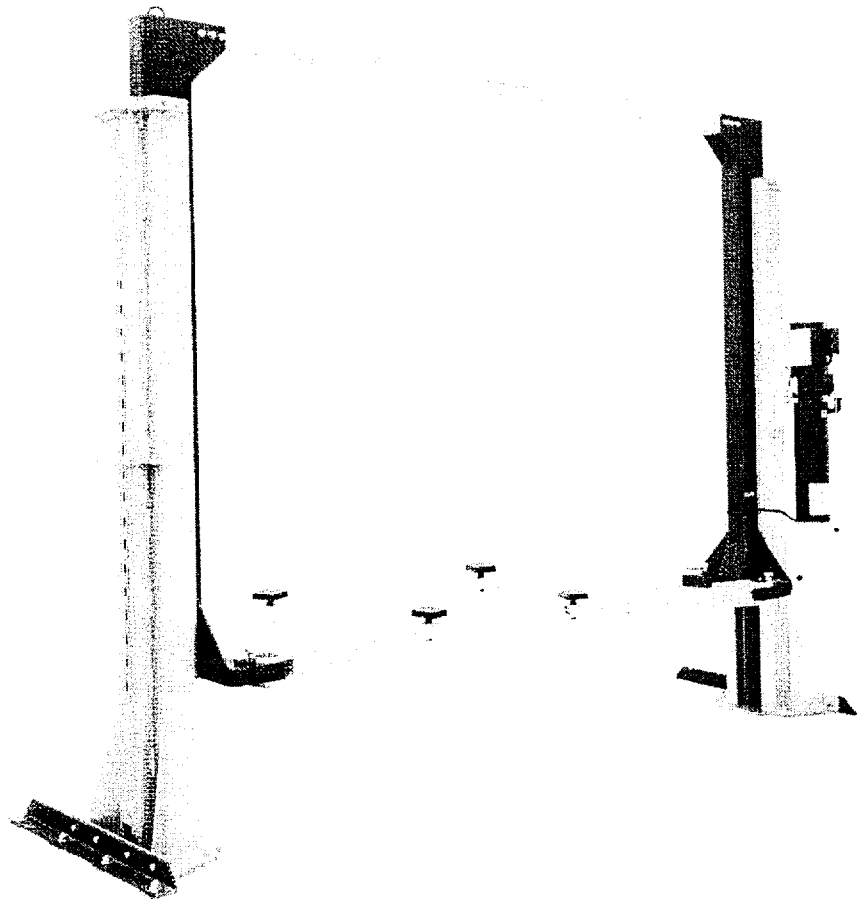

INSTALLATION AND OPERATION MANUAL

SAVE THESE INSTRUCTIONS

**READ ALL INSTRUCTIONS
BEFORE USING LIFT**

MAR. 2000 6-2206



P.O. Box 15540 Richmond, VA 23227
804-798-8922
www.accu-turn.com 1-800-551-2228

| TABLE OF CONTENTS | PAGE |
|--|-------------|
| 1. SAFETY AND OPERATING INSTRUCTIONS | 1 |
| 2. SPECIFICATIONS | 2 |
| 3. CONTENTS | 3 |
| 4. INSTALLATION REQUIREMENTS AND TOOLS | 3 |
| 5. INSTALLATION INSTRUCTIONS | |
| 5.1 Unpacking Procedure | 4 |
| 5.2 Bay Layout | 5 |
| 5.3 Tower Positioning and Setup | 6 |
| 5.4 Arm Installation | 7 |
| 5.5 Arm Locks Adjustment | 7 |
| 5.6 Power Pack Installation | 8 |
| 5.7 Hydraulic System Bleeding & Leveling Procedure | 9 |
| 5.8 Safety Cable Adjustment | 12 |
| 5.9 Tower Positioning and Anchoring | 14 |
| 5.10 Shimming of the Remaining Tower | 15 |
| 5.11 Installation of Safety Covers | 17 |
| 6. PERIODIC MAINTENANCE | 18 |
| 7. SAFETY AWARENESS | 19 |
| 8. PARTS MANUAL | 20 |
| a. Lift Assembly Diagram | 21 |
| b. Lift Part List | 22 |
| c. Hydraulic System Diagram | 24 |
| d. Hydraulics Part List | 25 |
| e. Power Pack Diagram | 26 |
| f. Power Pack Part List | 27 |

1. SAFETY AND OPERATING INSTRUCTIONS

1. Read all instructions.
2. Inspect lift daily. Do not operate if it malfunctions or problems have been encountered.
3. Never attempt to overload the lift. The manufacturer's rated capacity is shown on the identification label on the power side column.
Do not override the operating controls or the warranty will be void.
4. Only trained and authorized personnel should operate the lift. Do not allow customers or bystanders to operate the lift or be in the lift area.
5. Position the lift support pads to contact the vehicle manufacturer's recommended lifting points. Raise the lift until the pads contact the vehicle. Check pads for secure contact with the vehicle, then raise the lift to the desired working height.
6. Some pickup trucks may require an optional truck adapter to clear running boards or other accessories.
NOTE: Always use all 4 arms to raise and support vehicle.
7. **Caution! Never work under the lift unless the mechanical safety locks are engaged.**
8. Note that the removal or installation of some vehicle parts may cause a critical load shift in the center of gravity and may cause the vehicle to become unstable. Refer to the vehicle manufacturer's service manual for recommended procedures.
9. Always keep the lift area free of obstruction and debris. Grease and oil spills should always be cleaned up immediately.
10. Never raise vehicle with passengers inside.
11. Before lowering check area for any obstructions.
12. Before driving vehicle between the towers, position the arms to the drive-through position to ensure unobstructed clearance. Do not hit or run over arms as this could damage the lift and/or vehicle.
13. Before removing the vehicle from the lift area, position the arms to the drive-through position to prevent damage to the lift and /or vehicle.
14. Care must be taken as burns can occur from touching hot parts.
15. Do not operate equipment with a damaged cord or if the equipment has been dropped or damaged – until a qualified serviceman has examined it.
16. Do not let cord hang over table, bench or counter or come in contact with hot manifolds or moving fan blades.
17. If an extension cord is necessary, a cord with a current rating of two or more than that of the equipment should be used. Cords rated for less current than the equipment may overheat. Care should be taken to arrange the cord so that it will not be tripped over or pulled.
18. Always unplug the equipment from electrical outlet when not in use. Never use the cord to pull the plug from the outlet. Grasp plug and pull to disconnect.

2. SPECIFICATIONS

Capacity:
 Overall Width:
 Width Between Columns:
 Drive-Thru Width:
 Overall Extended Height:
 Overhead Clearance:
 Height of Lift Pads, Lowered:
 Height of Lift Pads, Raised:
 Front Arm Retracted Length:
 Front Arm Extended Length:
 Rear Arm Retracted Length:
 Rear Arm Extended Length:
 Maximum Lifting Height:
 Lift Time:
 Power Requirements (Standard):
 Shipping Weight:

| | |
|----------------------------|---------|
| 9000 lbs. | 4083 kg |
| 134" | 3404mm |
| 115" | 2921mm |
| 95" | 2413mm |
| 159" | 4039mm |
| 84" | 2134mm |
| 4 ½" | 114mm |
| 6 ½" | 165mm |
| 27" | 686mm |
| 42" | 1067mm |
| 35" | 889mm |
| 57" | 1448mm |
| 78 ½" | 1994mm |
| 45 seconds | |
| 230 Volts AC, 1 Ph., 60Hz. | |
| 1970 lbs. | 894 kg |

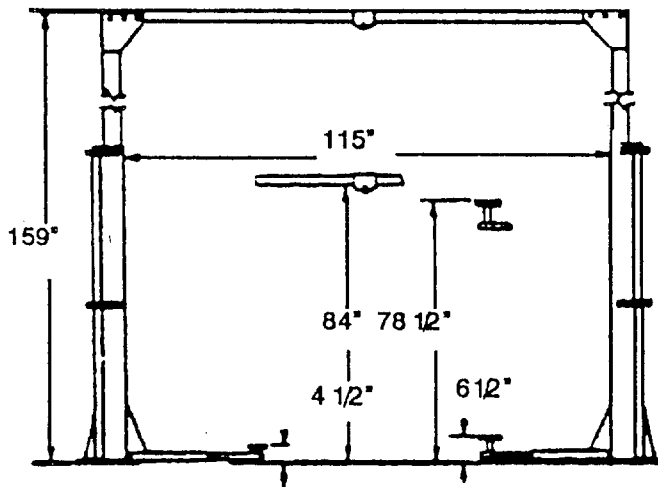

Figure 1

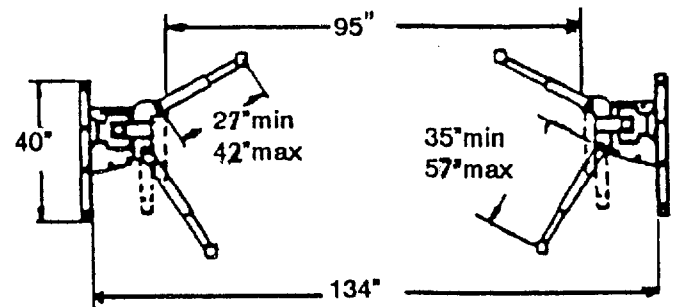

Figure 2

3. CONTENTS

The complete Twin Post lift is contained in two (2) packages:

1. The **main structural components** are packed in a steel frame.
2. The remaining parts are packed in an **accessory box**.

Main Structural Components includes:

- 1pc. - Power side tower and carriage assembly
- 1pc. - Power side carriage cover
- 1pc. - Slave side tower and carriage assembly
- 1pc. - Slave side carriage cover
- 1pc. - Crossmember
- 1pc. - Crossmember hydraulic line (2pc.)

Accessory box contents:

- 2pcs. - Front arm ass'y (Short) w/arm pins
- 2pcs. - Rear arm ass'y (Long) w/arm pins
- 1pc. - Power Pack
- 1pc. - Hydraulic fitting assembly
- 4pcs. - Arm riser pads
- 2pcs. - Tower stabilizer legs (3" x 3" x 40" Angle)
- 6pcs. - Tower safety slot covers
- 1pc. - Safety release handle w/knob
- 1pc. - Safety release cable assembly
- 1pc. - Engine lift bracket ass'y
- 1pc. - Hardware package w/Packing List
- 1pc. - Owner's manual
- 1pc. - ALI manual "Lifting It Right"
- 1pc. - Automotive Lift Safety Tips
- 1pc. - Automotive Lift, Operation, Inspection and Maintenance manual
- 1pc. - "ALI" Quick Reference Guide

4. INSTALLATION REQUIREMENTS AND TOOLS

IMPORTANT: It is the user's responsibility to provide a satisfactory installation area for the lift. Lifts should only be installed on level concrete floors with a minimum thickness of five (5) inches or 130 mm. Concrete must have a minimum strength of 4000 psi or 30 MPa and should be aged thirty (30) days prior to installation. Please consult the architect, contractor or engineer if doubt exists as to the strength and feasibility of the floor to enable proper lift installation and operation.

It is the user's responsibility to provide all wiring for electrical hook-up prior to installation and to insure that the electrical installation conforms to local building codes. Where required, it is the user's responsibility to provide an electrical isolation switch located in close proximity to the lift that will enable emergency stop capability and isolate electrical power from the lift for any servicing requirements.

Tools Required:

- | | | | |
|----|----------------------------------|----|--|
| a. | 16ft. Measuring Tape | j. | Step Ladder |
| b. | Chalk Line | k. | Side Cutters |
| c. | Rotary Hammer Drill | l. | Phillips screwdrivers |
| d. | 3/4" diameter Masonry Drill Bit | m. | 24" Bleeder Hose (clear) w/ 3/8" JIC F fitting on one end |
| e. | Hammer | n. | 4" x 4" Wooden Blocks (for unpackaging) |
| f. | SAE Wrenches and Ratchet Set | o. | 15ft. Hydraulic Hose w/ 3/8" JIC Swivel on one end - 3/8" JIC M on other end |
| g. | 2ft. Level | | |
| h. | 4ft. Level | | |
| i. | Crow Bar (for shim installation) | | |

5. INSTALLATION INSTRUCTIONS

When the lift arrives on site, please read the owner's manual and check for any freight damages. Also, check the contents to make sure no parts are missing before starting installation. Gather all the tools listed and make sure the installation instructions are fully understood before commencing installation.

5.1 UNPACKING PROCEDURE

1. **Important!** Place the main structural components on wooden blocks so that the steel frames can be removed.
2. Remove plastic wrapping.
3. Remove crossmember, both carriage covers and 2pc. crossmember hydraulic line. (1pc. is 100"Lg., the other piece is 18"Lg.)
4. Remove steel frame.
5. Lay towers on floor with the carriage side up.
6. Check the installation area for obstructions. (Lights, Heating Ducts, Ceiling, Floor Drains...etc.)

7. Prepare the bay by selecting the location of the lift relative to the walls. Clear area of all packaging materials to avoid trip hazards. Draw a chalk line on the floor to represent the center line of the bay and a second chalk line crossing at 90° for locating the lift towers. Refer to **Figures 3**.

5.2 BAY LAYOUT

Figure 3

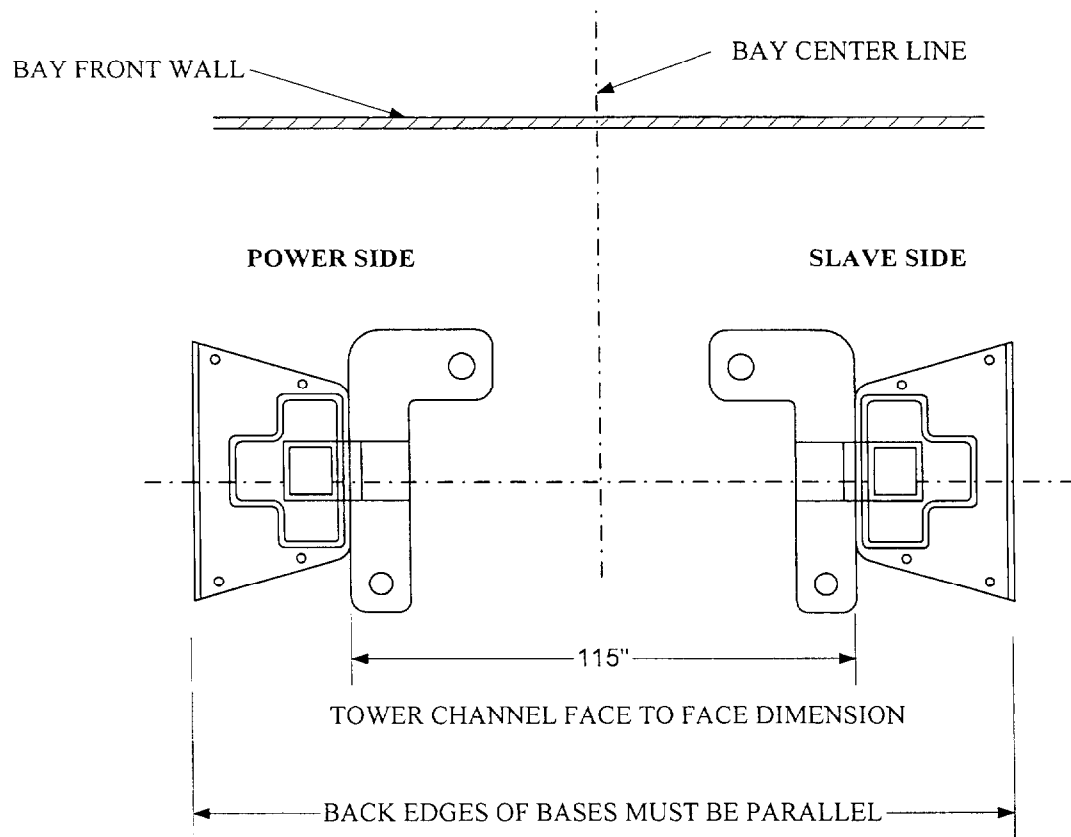

5.3 TOWER POSITIONING AND SETUP

1. Locate the power side tower (With pump mounting bracket) and slave side tower to the relative position as shown on **Figure 3**. **Check the 115" dimension.**
2. Assemble the crossmember hydraulic line, and install it in the crossmember, with the 90° bend on the power side. See **Figure 4**.
3. Place crossmember on support brackets on top of carriage, and connect crossmember hydraulic line.

NOTE: Before connecting this line, remove all caps from the fitting (on power side) and the "T" (on slave side). See **Figure 4**.

4. Install safety cable in the crossmember. The looped end should be fished from the power side to the slave side.
5. Install one (1) ½" - 13UNC x 5 ½ Lg. bolt in the middle bolt hole at both ends of the crossmember. **Be sure the SAFETY CABLE passes ABOVE the BOLTS.** See **Figure 4**.

NOTE: SAFETY CABLE TO BE LOCATED ABOVE BOLTS.

Figure 4

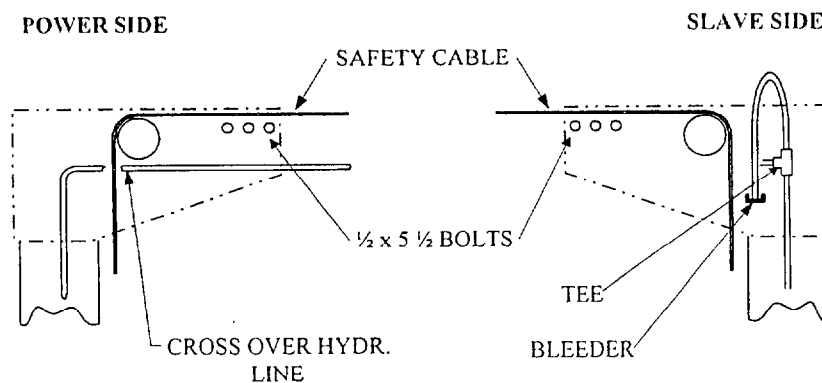

**BEFORE SHIMMING AND ANCHORING THE TOWERS,
THE HYDRAULIC SYSTEM HAS TO BE INSTALLED AND BLED
&
THE ARMS HAVE TO BE INSTALLED**

5.4 ARM INSTALLATION

1. Remove (4) 5/16"-18UNC x 3/4"LG. hex head bolts that are locking the arm pins to the arm. Install arms to carriages, so that the short arms are on the front, and the long arms are on the rear. Refer to **Figure 5**.
2. Grease and insert arm pins. Align notch on arm pins to the tapped hole on the arm. Using the 5/16" hex head bolts removed in previous step, reinstall and tighten securely.
3. Install lift pads in all arms.

ARM INSTALLATION

Figure 5

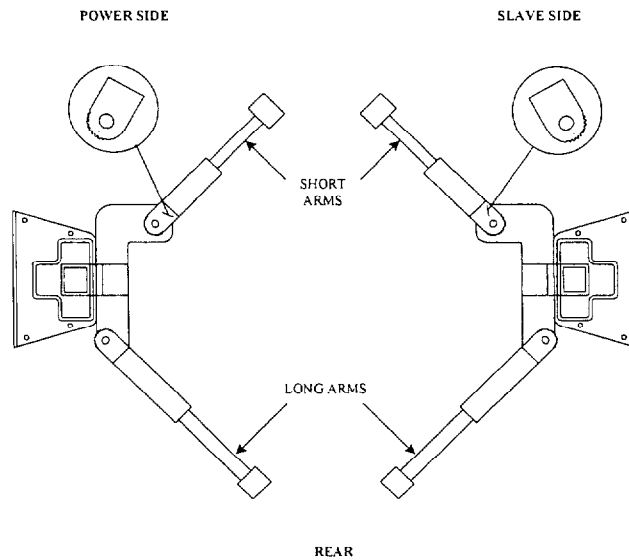

5.5 ARM LOCKS ADJUSTMENT

The arm locks are designed to automatically engage when the lift is raised and disengage when the lift is fully lowered. To adjust, refer to **Figure 6**.

ARM LOCK ADJUSTMENT

Figure 6

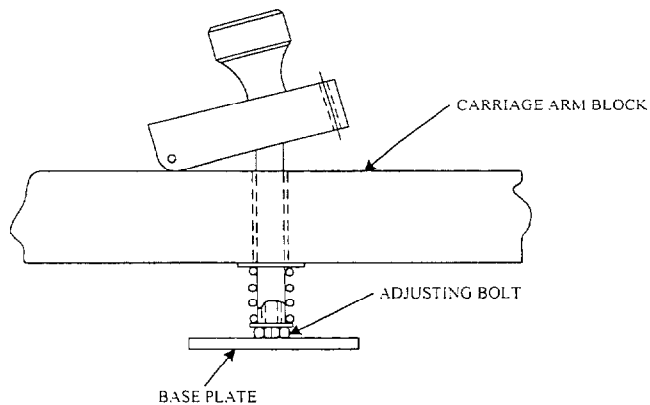

5.6 POWER PACK INSTALLATION

Note: Two men are required to mount the power pack.

REMOVE THE POWER PACK FROM THE ACCESSORY BOX

1. Remove the **red** plastic cap located at the rear of the power pack, and install the 90° fitting (item 2) located in the hardware kit.
2. Bolt power pack on the outside of the mounting bracket on the power side tower using four (4) 5/16"-18UNC x 1"LG. hex head bolts, lock washers, flat washers and nuts. Do not tighten.
3. Remove filler cap from power pack, and fill reservoir with approximately 3.5 Gal. (13.2 L) of ISO32 hydraulic oil (10 weight hydraulic oil). Remove breather screw when filling and replace when full. Refer to **Figure 7**.
4. A **Certified Electrician** must connect the 230 volt/single phase power to the motor. The electrical diagram is provided, refer to **Figure 8**. The motor rotation is indicated on the power pack. After the motor is wired, jog the motor (push button on power pack) and verify the motor rotation.

POWER PACK DETAILS

Figure 7

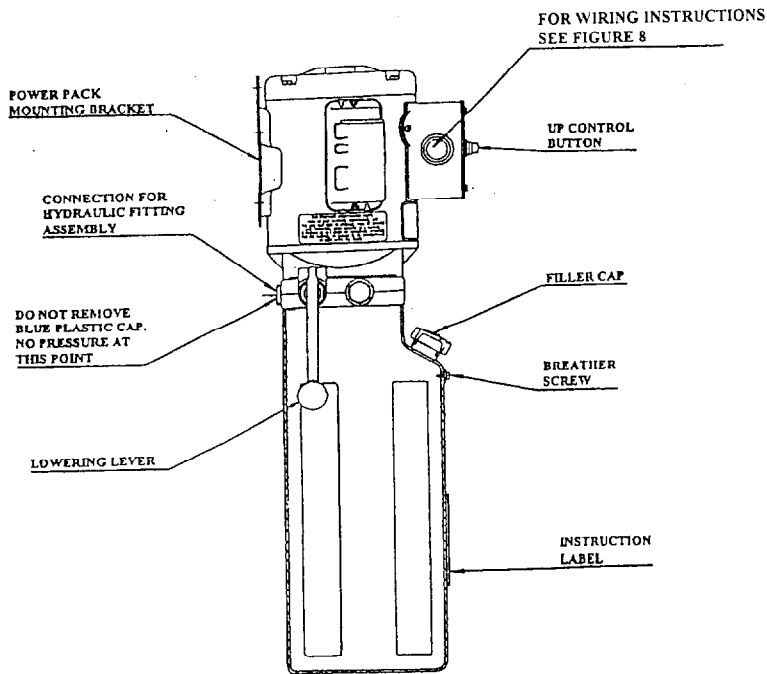

ELECTRICAL DIAGRAM

Figure 8

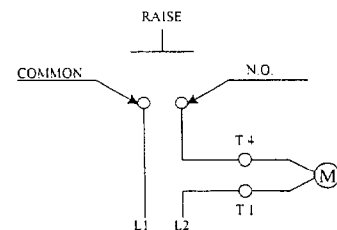

5.7 HYDRAULIC SYSTEM BLEEDING AND LEVELING PROCEDURE

Refer to **Figure 9** and **10**, and **page 24** on the Hydraulic System Part List.

Note: Save hydraulic caps and plugs for future use.

1. Ensure that both sides of the lift are fully lowered.
2. Attach a 15' hydraulic hose to bleeder line coming down the face of the slave side carriage. Connect this hose to the 90° fitting attached to the power pack.
3. Attach a small bleeder hose (24" long) with a 1/4" JIC (hydraulic) male fitting on one side to the 1/4" hydraulic line located on the left side tower. Place the other end of the line into the reservoir inlet.
4. Press up button.
5. Run power pack until clear oil is seen coming out of the 24" bleeder hose.

Note: Do not allow slave side more than 6" high.

6. Disconnect bleeder hose and connect 3/8" and 1/4" hydraulic lines to bottom of valve block. Refer to **Figure 9**.
7. Do not tighten any hydraulic fittings until all connections have been made.

HYDRAULIC FITTING ASSEMBLY

Figure 9

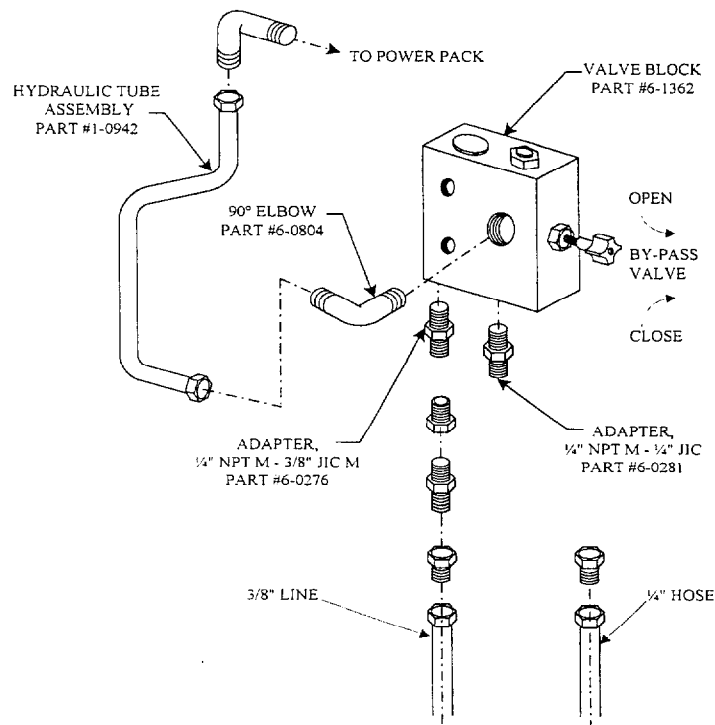

8. Disconnect hydraulic hose from bleeder line on the right side carriage, re-install the steel bleeder plug and tighten.
9. Remove plug from item 3. Install item 3 (page 24) to the 90° fitting on the power pack (item 2).
10. Attach the other end of item 3 to the 90° fitting (item 2) on the valve block.
11. TIGHTEN ALL HYDRAULIC CONNECTIONS.
Caution: Over tightening could cause the flare seal to break.
12. Open by-pass valve, and raise lift 2"-3" and stop. Close by-pass valve and lower lift completely. Repeat 3 times.

Note: Slave side will be about 1"-2" higher
13. Raise and lower the lift 2-3 times, raising about 12" at a time.
14. Power up and lower lift on to the first safety position on the power side. Open by-pass valve and lower the slave side on to the first safety position. Close the by-pass valve. The lift is now synchronized hydraulically.
15. Both power and slave sides must be completely down.
16. Check and add hydraulic fluid to power pack before cycling lift.
17. Set up a vehicle on the lift after anchoring to make sure hydraulics are operating properly.

HYDRAULIC SYSTEM SCHEMATIC

Figure 10

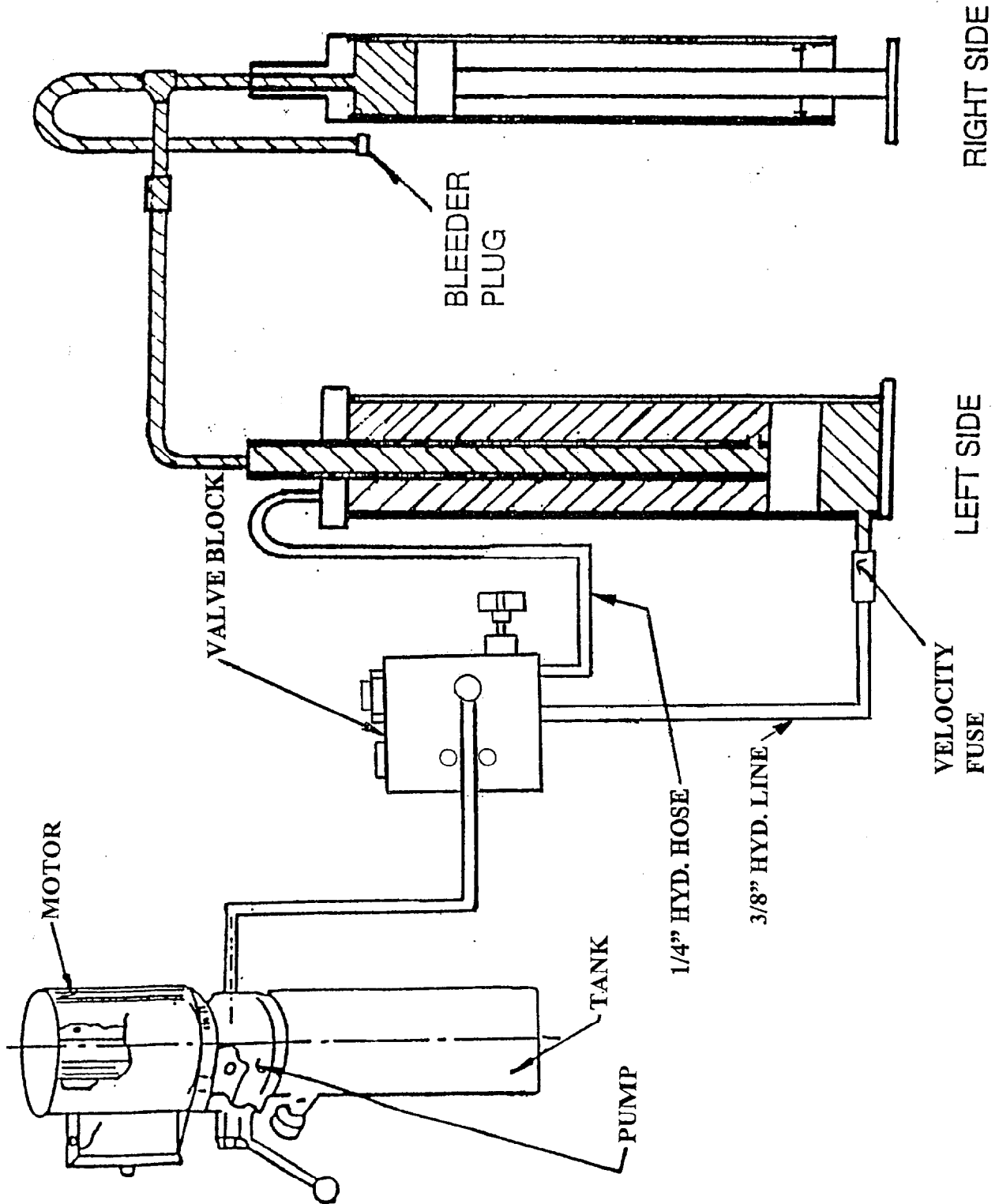

5.8 SAFETY CABLE ADJUSTMENT

1. The safety cable (PREVIOUSLY INSTALLED IN CROSSMEMBER) now needs to be connected and adjusted to ensure that both safety mechanisms engage and disengage in both towers at the same time.
2. Attach safety release handle to the power side safety mechanism using a cotter pin as shown in **Figure 11**.
3. Run the safety cable over the pulleys at the top of each carriage. With an assistant holding one end, move the safety cable up and down to be sure it is not snagging in the crossmember. **Recheck that the safety cable is running above the crossmember bolts.**
4. Connect the "loop end" of the safety cable to the slave side safety mechanism using the 1/4" x 3/8" shoulder bolt. **Use lock tight to secure this shoulder bolt.** See **Figure 11**.
5. Place the "male threaded end" of the safety cable through the "L" bracket on the power side safety mechanism. Install a 1/4" nut above and below the bracket. **Do not tighten the nuts.** See **Figure 11**.

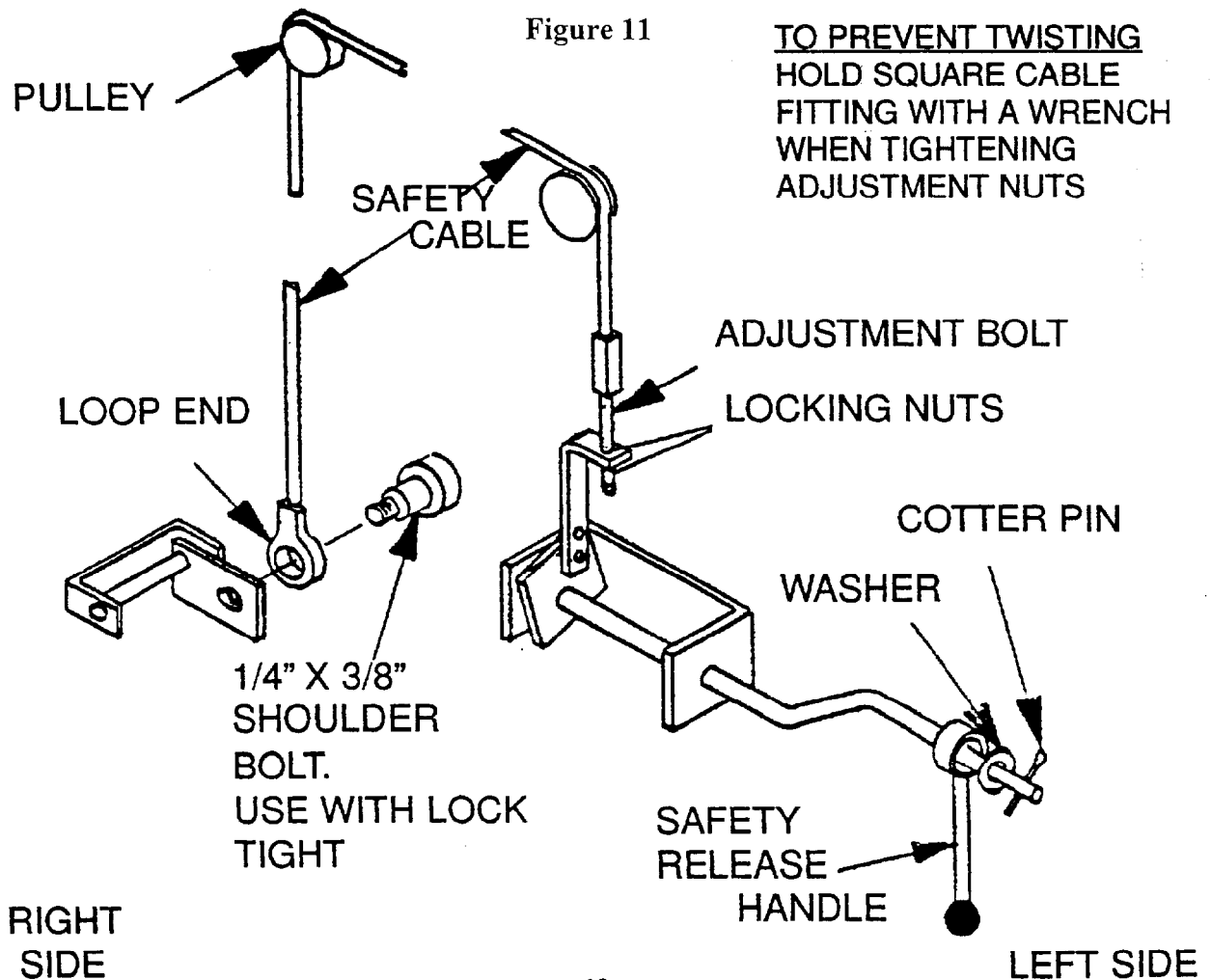

6. Raise the lift until the safety dog is in the middle of the first safety slot. (Safety slot can be seen through the square slots on the back of the tower). **In this position, the safety can move freely when the safety release handle on the left side is pulled down.**
7. Adjust the safety cable on the left side mechanism so that both safety dogs travel from full engagement position to full release position when the safety release handle is pulled down. Tighten 1/4" lock nut on safety cable when adjustment is completed.
8. Lower carriage (by pulling down on the power pack control lever) until both safety dogs engage in the first safety slot. **If safety dogs do not engage at the same time, a HYDRAULIC ADJUSTMENT is made to the RIGHT SIDE - proceed as follows:**

Figure 12
WHEN RIGHT SIDE IS HIGH

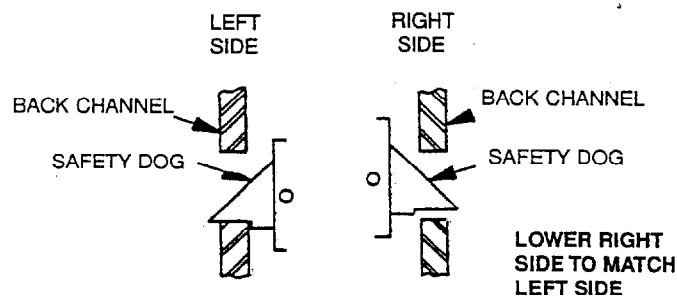

Open by-pass valve and jog down control lever until right side is on safety stop level with left side. **CLOSE BY-PASS VALVE.**

Figure 13
WHEN RIGHT SIDE IS LOW

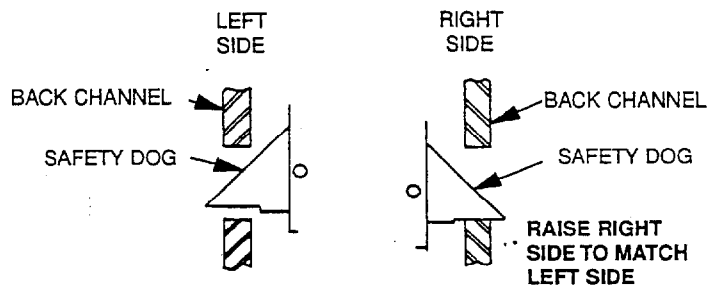

Open by-pass valve, raise lift, until right side safety dog is 1" higher than left side safety dog. **CLOSE THE BY-PASS VALVE.**

LOWER LIFT UNTIL the LEFT SIDE SAFETY DOG ENGAGES IN the first (bottom) safety slot. OPEN BY-PASS VALVE, and jog DOWN on the control lever until the RIGHT SIDE SAFETY DOG engages in the first (bottom) safety slot. CLOSE THE BY-PASS VALVE.

5.9 TOWER POSITIONING AND ANCHORING

WARNING! Failure to follow these instructions may cause an unsafe operating condition.

WARNING! Before proceeding with installation, review Section 4: Installation & Tools.

1. Bolt tower stabilizer legs (3" x 3" channels – 40" LG.) to tower base. Be sure long extension legs point to REAR of lift (**Fig. 14**).
2. Using a 4ft. level on top of the crossmember, determine which column is higher (**Fig. 15**).
3. Using 2 ft. level on the sides of the high column, ensure that the column is level in the vertical position (**Fig. 16**). Use shims under the column baseplate to hold the column level. Ensure that the base plate is completely supported by shims where it does not contact the floor (**Fig. 17**).

WARNING! Do not use more than 1/2" (13mm) of shims. Anchor bolts supplied allow for a maximum of 1/2" (13mm) of shim. If more than 1/2" (13mm) of shims are required, **DO NOT** proceed with installation and contact Product Manufacturer / Supplier for further details.

Figure 14

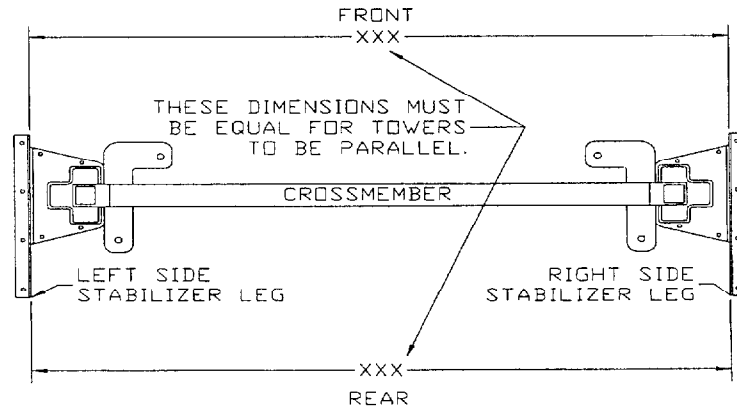

Figure 15

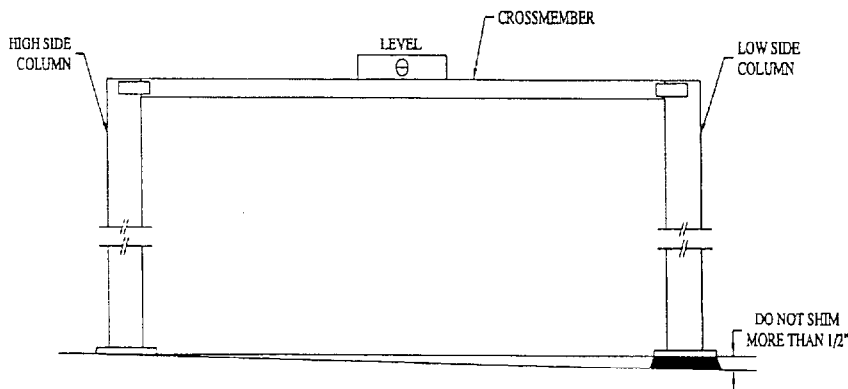

Figure 16

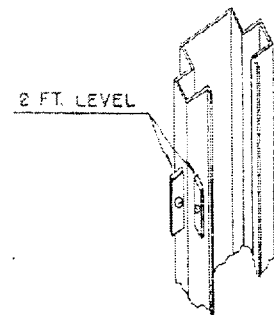

Figure 17

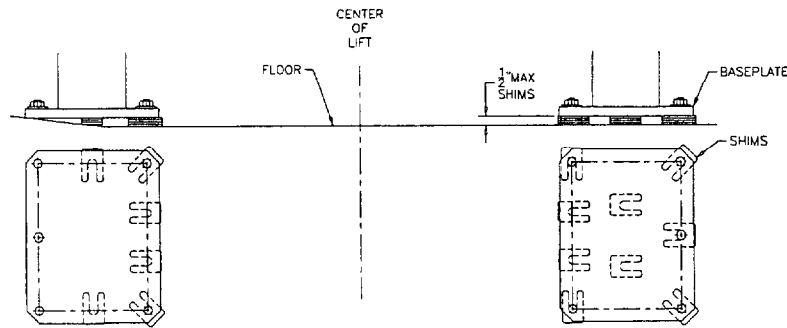
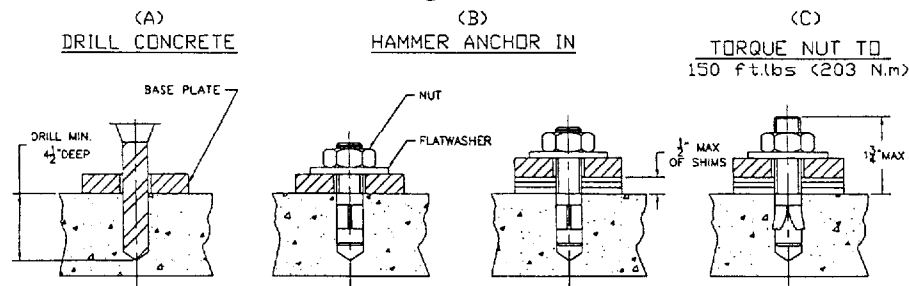

Figure 18



4. Refer to Bay Layout (**Fig. 3**) to ensure that the column is still in the proper position. Using a rotary hammer drill with a 3/4" masonry drill bit, drill holes in the floor on the high side column using the tower baseplate and stabilizer leg as a template. Make sure that the 3/4" masonry drill is in good condition (**Fig 18 (A)**).
5. Carefully clean out drilling dust from the anchor holes. Hammer in the anchor bolts (**Fig. 18 (B)**). Hand tighten all anchor bolts.
6. Reconfirm that the column is level front to rear and side to side (**Fig. 16**). Add or remove shims as required.
7. Torque all anchor bolts to 150 ft-lbs. (203 Nm), continually checking that the column is level as you proceed. If anchor bolts do not tighten to 150 ft-lbs. OR project more than 1 3/4" above the concrete surface (**Fig 18(C)**), the concrete MUST be replaced by an appropriate concrete pad. (*Consult Product Manufacturer / Supplier for further details*).

5.10 SHIMMING OF THE REMAINING COLUMN (LOW SIDE)

1. Before shimming the remaining tower, both safety dogs MUST be engaged on the first safety lock.
2. Using a 4ft. level on the crossmember (**Fig. 15**) and a 2ft. level on the low side column (**Fig. 16**), shim underneath the baseplate until the crossmember and column are level. Ensure that the baseplate is completely supported by shims where it does not contact the floor (**Fig 17**). After ensuring the tower is level, install remaining bolts in crossmember. Be sure safety cable passes **ABOVE THE BOLTS**. Tighten all crossmember bolts.

WARNING! *Do not use more than 1/2" (13mm) of shims. Anchor bolts supplied allow for a maximum of 1/2" (13mm) of shim. If more than 1/2" (13mm) of shims are required, **DO NOT** proceed with installation and contact Product Manufacturer / Supplier for further details.*

3. Refer to Bay Layout (**Fig. 3**) to ensure that the column is still in the proper position. Using a rotary hammer drill with a 3/4" masonry drill bit, drill holes in the floor on the low side column using the column baseplate and stabilizer leg as a template. Make sure that the 3/4" masonry drill is in good condition (**Fig 18 (A)**).
4. Carefully clean out drilling dust from the anchor holes. Hammer in the anchor bolts (**Fig. 18(B)**). Hand tighten all anchor bolts.
5. Reconfirm that the crossmember is level (**Fig. 15**) and that the column is level front to rear and side to side (**Fig. 16**). Add or remove shims as required.
6. Torque all anchor bolts to 150 ft-lbs. (203 Nm), continually checking that the crossmember and column are level as you proceed. If anchor bolts do not tighten to 150 ft-lbs. OR project more than 1 3/4" above the concrete surface (**Fig 18(C)**), the concrete **MUST** be replaced by an appropriate concrete pad. (*Consult Product Manufacturer / Supplier for further details*).
7. Verify that the entire lift is level both horizontally and vertically to ensure optimum lifting performance.

***Perform a monthly inspection and torque all anchor bolts to 150 ft-lbs. (203 Nm).**

5.11 INSTALLATION OF SAFETY COVERS

1. Install VISU (clear) safety covers over the safety slots on the back of both the left side and right side towers. These eight (8) covers are in the accessory box. Use 1/4" x 5/8"lg. round head screws to secure these covers.
2. Install the carriage safety covers on the front of each carriage (to cover safety mechanism and cable). The left side cover has two (2) slots cut out at the bottom, right side cover has one (1) slot cut out at the bottom.

NOTE: Place covers over safety cables and be sure they BUTT securely against the gusset on the bottom of the carriage. Secure with the #10 x 3/4" self-tapping screws - INSTALL 2 SCREWS AT THE TOP OF EACH COVER.

HYDRAULIC LEVELING

Should your lift come out of synchronization, ie. one carriage is higher than the other, it is necessary to level the lift hydraulically.

This can easily be done by following the procedure entitled "SAFETY CABLE ADJUSTMENT" (5.8) steps 6,7, and 8, referring to **Figures 12 & 13**.

If you require assistance, contact your service representative.





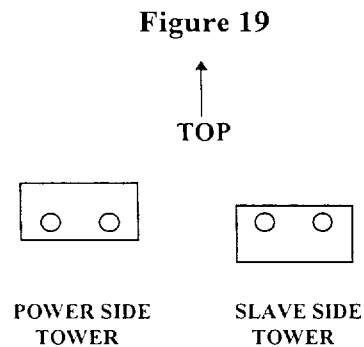





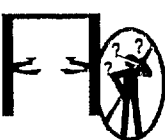

6. PERIODIC MAINTENANCE

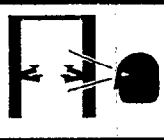
1. Inspect the lift daily, to assure the mechanical safety is operating correctly.
2. Check the sight on the power pack tank (when lift is in the down position) to verify tank is full of hydraulic oil.
3. Check the telescopic arms for movement. Clean any grease or oil from the lifting pads.
4. Raise and lower the lift at the beginning of each shift, without a vehicle on it, to verify lift is operating properly.
5. Lubricate safety dog mechanism with WD-40 monthly. Remove cover and spray WD-40 through safety slots in rear channel.
6. Lubricate the threads on the lifting pads
7. Inspect anchors for tightness (150ft. lbs. torque). If anchors require frequent tightening, then both anchors and floor must be inspected.
8. Check bolts on carriage stops for tightness. Note: The carriage stop on the slave side tower should have the thicker side facing downwards, and on the power side facing upwards. Refer to **Figure 19**.

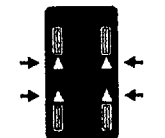

10. Check lift for synchronization periodically.
11. Change hydraulic oil every two years.

7. SAFETY AWARENESS - AUTOMOTIVE LIFT INSTITUTE (ALI)

| | | | | | |
|--|--|--|---|---|---|
|  <p>WARNING</p> |  <p>WARNING</p> |  <p>CAUTION</p> |  <p>CAUTION</p> |  <p>SAFETY INSTRUCTIONS</p> |  <p>SAFETY INSTRUCTIONS</p> |
| <p>Clear area if vehicle is in danger of falling.</p> | <p>Position vehicle with center of gravity midway between adapters.</p> | <p>Lift to be used by trained operator only.</p> | <p>Authorized personnel only in lift area.</p> | <p>Read operating and safety manuals before using lift.</p> | <p>Proper maintenance and inspection is necessary for safe operation.</p> |
|  <p>WARNING</p> |  <p>WARNING</p> |  <p>CAUTION</p> |  <p>CAUTION</p> |  <p>SAFETY INSTRUCTIONS</p> | <p>The messages and pictographs shown are generic in nature and are meant to generally represent hazards common to all automotive lifts regardless of specific style.</p> <p>Funding for the development and validation of these labels was provided by the Automotive Lift Institute, P.O. Box 23116, Indianapolis, IN 46223-1116. They are protected by copyright. Set of labels may be obtained from ALI or its member companies.</p> <p>© 1998 by ALI, Inc. ALI/ALI 10/11</p> |
| <p>Remain clear of lift when raising or lowering vehicle.</p> | <p>Avoid excessive rocking of vehicle while on lift.</p> | <p>Use vehicle manufacturer's lift points.</p> | <p>Always use safety stands when removing or installing heavy components.</p> | <p>Do not operate a damaged lift.</p> | |
|  <p>WARNING</p> |  <p>WARNING</p> |  <p>CAUTION</p> |  <p>CAUTION</p> | | |
| <p>Do not override self-closing lift controls.</p> | <p>Keep feet clear of lift while lowering.</p> | <p>Use height extenders when necessary to ensure good contact.</p> | <p>Auxiliary adapters may reduce load capacity.</p> | | |

Warning Labels for 2-post surface mounted lifts. Daily review of these Safety Messages and Warnings is suggested.



TWIN POST MODEL # AC9021

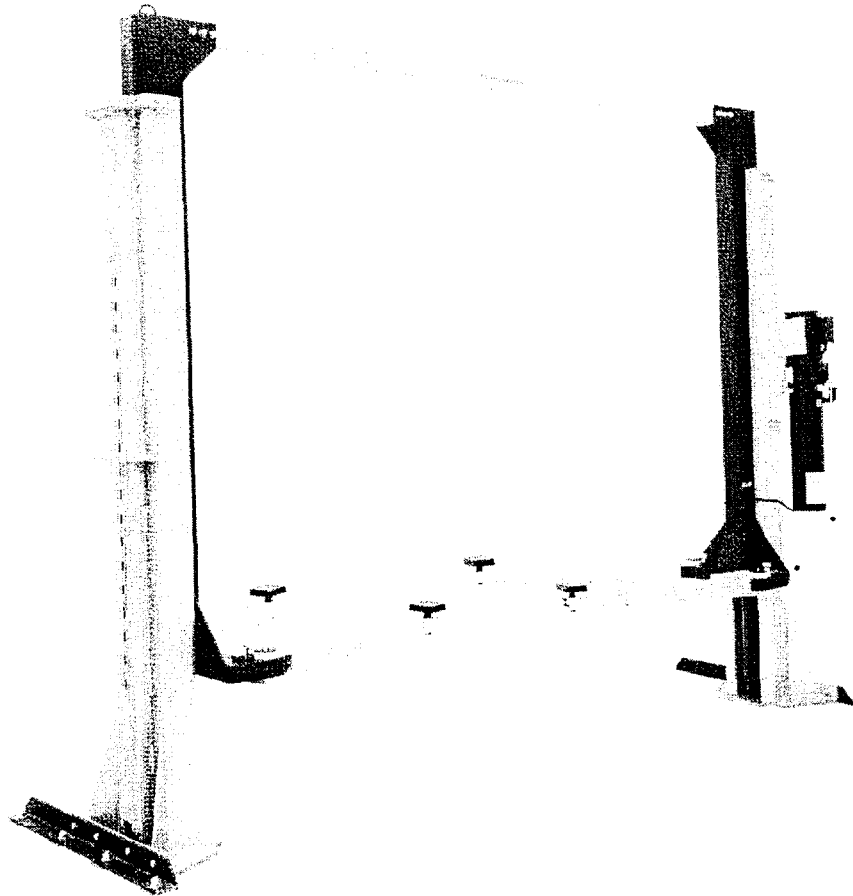

EXPLODED VIEWS AND PARTS LISTS

SAVE THESE INSTRUCTIONS

**READ ALL INSTRUCTIONS
BEFORE USING LIFT**

MAR. 2000 6-2206



P.O. Box 15540 Richmond, VA 23227
804-798-8922
www.accu-turn.com 1-800-551-2228

TWIN POST ASSEMBLY

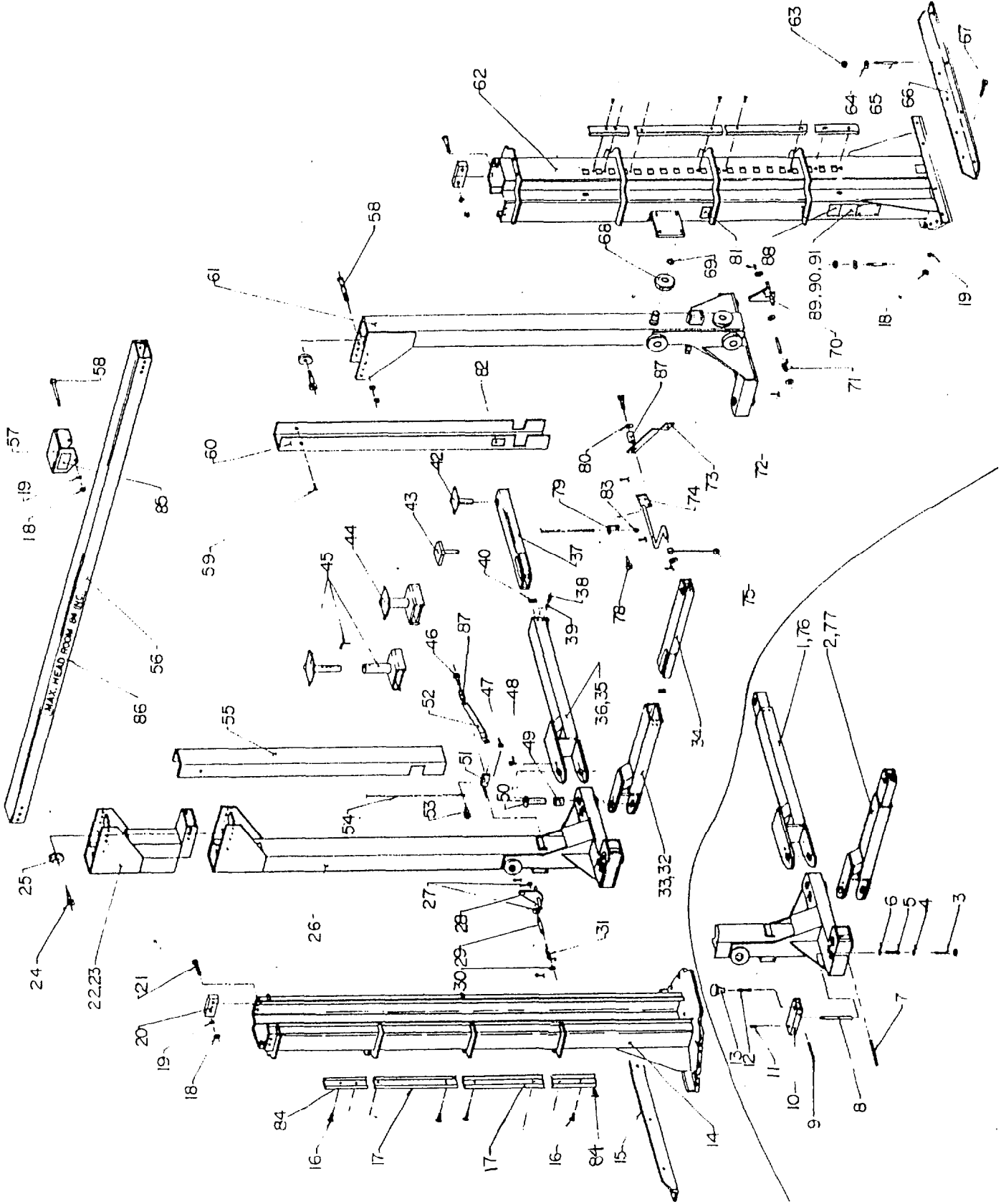

TWIN POST PART LIST

| ITEM | QTY. | DESCRIPTION | PART # |
|------|------|---|--------|
| 1 | 1 | LONG LOCKING ARM ASSEMBLY, R.S | 4-0600 |
| 2 | 1 | SHORT LOCKING ARM ASSEMBLY, R.S. | 4-0602 |
| 3 | 4 | HEX HD. BOLT 1/4" - 20UNC X 1 1/4" LG. | 6-0027 |
| 4 | 4 | FLAT WASHER 1/4" I.D. X 1 1/4" O.D. | 6-0626 |
| 5 | 4 | PLUNGER SPRING | 1-0939 |
| 6 | 4 | FLAT WASHER, 1/2" I.D. | 6-0248 |
| 7 | 4 | PIVOT PIN | 1-0333 |
| 8 | 4 | PLUNGER | 1-0745 |
| 9 | 4 | ROLL PIN, 1/8" X 1" LG. | 6-0437 |
| 10 | 4 | RACK | 2-0249 |
| 11 | 4 | SOCKET HD. SET SCREW, 1/4" - 20UNC X 1/2" LG. | 6-0438 |
| 12 | 4 | THREADED ROD, 3/8" - 16UNC X 1 1/2" LG. | 1-1135 |
| 13 | 4 | KNOB | 1-0208 |
| 14 | 1 | TOWER WELDMENT, R.S. | 4-0394 |
| 15 | 1 | TOWER SUPPORT ANGLE, R.S. | 3-0097 |
| 16 | 16 | RD. HD. SCREW, 1/4" - 20UNC X 5/8" LG. | 6-0335 |
| 17 | 4 | TOWER SAFETY COVER | 2-1031 |
| 18 | 23 | HEX NUT, 1/2" - 13UNC | 6-0035 |
| 19 | 23 | LOCKWASHER, 1/2" I.D. | 6-0059 |
| 20 | 4 | CARRIAGE STOP | 1-0877 |
| 21 | 8 | HEX HD. BOLT, 1/2" - 13UNC X 2" LG. | 6-0769 |
| 22 | 2 | EXTENSION WELDING 24" LG. (OPTIONAL) | 3-0310 |
| 23 | 2 | EXTENSION WELDING 18" LG. (OPTIONAL) | 3-0226 |
| 24 | 2 | SHOULDER BOLT, 3/8" X 5/8" LG. | 6-0069 |
| 25 | 2 | SAFETY CABLE PULLEY | 1-0415 |
| 26 | 1 | CARRIAGE WELDMENT, R.S. | 4-0175 |
| 27 | 4 | THRUST WASHER 1/2" I.D. X .03" | 6-0387 |
| | 2 | THRUST WASHER 1/2" I.D. X .06" | 6-0419 |
| 28 | 1 | SAFETY DOG WELDMENT, R.S. | 2-0523 |
| 29 | 2 | PIVOT SHAFT, L.S. | 1-0260 |
| 30 | 3 | FLAT WASHER, 1/2" I.D. | 6-0063 |
| 31 | 1 | SAFETY SPRING, R.S. | 1-0249 |
| 32 | 1 | SHORT OUTER ARM WELDMENT, L.S. | 3-0607 |
| 33 | 1 | SHORT OUTER ARM WELDMENT, R.S. | 3-0606 |
| 34 | 2 | SHORT INNER ARM WELDMENT | 2-0192 |
| 35 | 1 | LONG OUTER ARM WELDMENT, L.S. | 3-0609 |
| 36 | 1 | LONG OUTER ARM WELDMENT, R.S. | 3-0608 |
| 37 | 2 | LONG INNER ARM WELDMENT | 2-0191 |
| 38 | 8 | HEX HD. BOLT, 3/8" - 28UNF X 5/8" LG. | 6-1512 |
| 39 | 8 | LOCKWASHER, 3/8" I.D. | 6-0058 |
| 42 | 4 | STANDARD LOW LIFTING PAD (OPTIONAL) | 2-0304 |
| 43 | 4 | LOW LIFTING PAD, NEOPRENE | 3-0170 |
| 44 | 4 | LIFT PAD | 3-0194 |
| 45 | 2 | ADJUSTABLE TRUCK PAD (OPTIONAL) | 3-0218 |
| 46 | 2 | BUTTON HD. HEX SOCK. SCREW, 1/4" - 20UNC X 1 1/2" LG. | 6-0909 |
| 47 | 2 | RETAINING RING | 6-0362 |
| 48 | 4 | HEX HD. BOLT, 5/16" - 18UNC X 3/4" LG. | 6-0423 |

| ITEM | QTY. | DESCRIPTION | PART # |
|------|------|---|--------|
| 49 | 8 | SELF LUBRICATING BEARING | 6-0551 |
| 50 | 4 | ARM PIN | 2-0439 |
| 51 | 1 | PIVOT SHAFT | 1-0326 |
| 52 | 1 | SAFETY LINKAGE BAR, R.S. | 3-0108 |
| 53 | 1 | SHOULDER BOLT, 1/4" X 3/8" LG. | 6-0244 |
| 54 | 1 | CABLE ASSEMBLY | 1-0239 |
| | 1 | SAFETY CABLE (EXTENSION 24" LG.) | 1-0736 |
| | 1 | SAFETY CABLE (EXTENSION 18" LG.) | 1-0737 |
| 55 | 1 | CARRIAGE COVER, R.S. | 3-0126 |
| 56 | 1 | CROSSMEMBER | 3-0093 |
| 57 | 1 | MOTOR LIFT BRACKET | 3-0109 |
| 58 | 7 | HEX HD. BOLT, 1/2" - 13UNC X 5 1/2" LG. | 6-0290 |
| 59 | 4 | SELF-TAPPING SCREW NO. 10 X 3/4" LG. | 6-0297 |
| 60 | 1 | CARRIAGE COVER, L.S. | 3-0125 |
| 61 | 1 | CARRIAGE WELDMENT, L.S. | 4-0174 |
| 62 | 1 | TOWER WELDMENT, L.S. | 4-0395 |
| 63 | 16 | HEX NUT, 3/4" -10UNC | 6-0737 |
| 64 | 16 | FLAT WASHER, 3/4" I.D. | 6-0738 |
| 65 | 16 | WEDGE ANCHOR, 3/4"-10UNC x 5 1/2" LG. | 6-1379 |
| 66 | 1 | TOWER SUPPORT ANGLE, L.S. | 3-0096 |
| 67 | 8 | HEX HD. BOLT, 1/2" -13UNC X 1 1/2" LG. | 6-0291 |
| 68 | 12 | CARRIAGE WHEEL ASSEMBLY | 2-0530 |
| 69 | 12 | RETAINING RING, 1 3/8" I.D. | 6-0233 |
| 70 | 1 | SAFETY DOG WELDMENT, L.S. | 2-0522 |
| 71 | 1 | SAFETY SPRING, L.S. | 1-0369 |
| 72 | 7 | COTTER PIN, 1/8" DIA. X 1" LG. | 6-0267 |
| 73 | 1 | SAFETY LINKAGE BAR, L.S. | 3-0107 |
| 74 | 1 | SAFETY RELEASE ARM | 3-0137 |
| 75 | 1 | SAFETY RELEASE HANDLE | 2-0293 |
| 76 | 1 | LONG LOCKING ARM ASSEMBLY, L.S. | 4-0599 |
| 77 | 1 | SHORT LOCKING ARM ASSEMBLY, L.S. | 4-0601 |
| 78 | 1 | SHOULDER BOLT, 1/4" I.D. X 3/4" O.D. | 6-0240 |
| 79 | 1 | CABLE CONNECTING BRACKET | 1-0259 |
| 80 | 1 | FLAT WASHER, 1/4" I.D. X 3/4" O.D. | 6-0060 |
| 81 | 1 | "ALI" PLATE | 6-0398 |
| 82 | 1 | " SAFETY RELEASE" DECAL | 6-0349 |
| 83 | 2 | HEX NUT, 1/4" - 20UNC | 6-0032 |
| 84 | 4 | TOWER SAFETY COVER | 2-1032 |
| 85 | 1 | "MAX CAP. 1000 LB." DECAL | 6-0352 |
| 86 | 1 | "MAX HEAD ROOM 84 INC." DECAL | 6-0353 |
| 87 | 2 | SPACER | 1-0307 |
| 88 | 1 | ETL CERTIFICATION DECAL | 6-0996 |
| 89 | 1 | ETL "CAUTION" DECAL | 6-0997 |
| 90 | 1 | ETL 2-POST WL SERIAL | 6-1126 |
| 91 | 4 | RIVET, 3/16" X 0.086" | 6-1100 |

TWIN POST HYDRAULIC SYSTEM PART LIST

| ITEM | QTY. | DESCRIPTION | PART # |
|------|------|--|--------|
| 1 | 1 | CROSS TUBE | 3-0113 |
| 2 | 2 | 90° ELBOW SAE M - 3/8" JIC, M | 6-0804 |
| 3 | 1 | HYDRAULIC TUBE ASS'Y (TO POWER PACK) | 1-0942 |
| 4 | 1 | ADAPTER 3/8" NPT, M x 3/8" JIC, M | 6-0011 |
| 5 | 2 | ADAPTER 3/4" NPT, M x 3/8" NPT, F | 6-0285 |
| 6 | 1 | HYDRAULIC TUBE ASS'Y | 3-0229 |
| 7 | 1 | ADAPTER 1/8" NPT, M x 1/4" JIC, M | 6-0280 |
| 8 | 1 | HYDRAULIC CYLINDER ASS'Y | 4-0173 |
| 9 | 1 | HYDRAULIC TUBE ASS'Y | 3-0114 |
| 10 | 1 | TUBE CLAMP | 6-0536 |
| 11 | 1 | ROUND HD. SCREW, 1/4"-20NC X 3/8"LG. | 6-1353 |
| 12 | 1 | 90° ELBOW 1/4" JIC, M x 1/4" JIC, M | 6-0278 |
| 13 | 1 | VELOCITY FUSE | 6-0422 |
| 14 | 2 | SHOULDER SCREW 1/2" x 5/8" LG. | 6-0425 |
| 15 | 1 | HYDRAULIC TUBE ASS'Y | 3-0110 |
| 16 | 2 | CIRCLIP | 6-0340 |
| 17 | 1 | HYDRAULIC VALVE BLOCK ASS'Y (C/W FITTINGS) | 6-1389 |
| 18 | 1 | HYDRAULIC VALVE BLOCK | 6-1362 |
| 19 | 1 | ADAPTER, 1/4" NPT, M x 1/4" JIC, M | 6-0281 |
| 20 | 1 | ADAPTER, 1/4" NPT, M x 3/8" JIC, M | 6-0276 |
| 21 | 4 | HEX BOLT, 5/16"-18UNC x 1"LG. | 6-0293 |
| 22 | 4 | FLAT WASHER, 5/16"ID | 6-0061 |
| 23 | 1 | POWER PACK | 6-1957 |
| 24 | 1 | "LIFT OPERATION" DECAL (8K) | 6-0593 |
| | 1 | "LIFT OPERATION" DECAL (9K) | 6-0481 |
| 25 | 4 | LOCKWASHER, 5/16"ID | 6-0674 |
| 26 | 4 | HEX NUT, 5/16"-18UNC | 6-0294 |
| 27 | 1 | HYDRAULIC CYLINDER ASS'Y | 3-0736 |
| 28 | 1 | PLUG 3/8" JIC | 6-0371 |
| 29 | 1 | ADAPTER 3/8" JIC, M x 3/8" NPT, M - 2 1/4" LG. | 6-0345 |
| 30 | 1 | TEE 3/8" JIC, F SWIVEL - 3/8" JIC, M - 3/8" JIC, M | 6-0284 |
| 31 | 1 | HYDRAULIC TUBE ASS'Y | 1-0093 |
| 32 | 1 | CROSS TUBE EXTENSION | 3-0112 |
| 33 | 1 | UNION 3/8" JIC, M x 3/8" JIC, M | 6-0268 |
| | | GLAND SEAL KIT, RIGHT SIDE | 0-0551 |
| | | PISTON SEAL KIT, RIGHT SIDE | 0-0159 |
| | | GLAND SEAL KIT, LEFT SIDE | 0-0161 |
| | | PISTON SEAL KIT, LEFT SIDE | 0-0160 |

POWER PACK: #6-2055 (AB-1381) 208-230V/1PH/60Hz

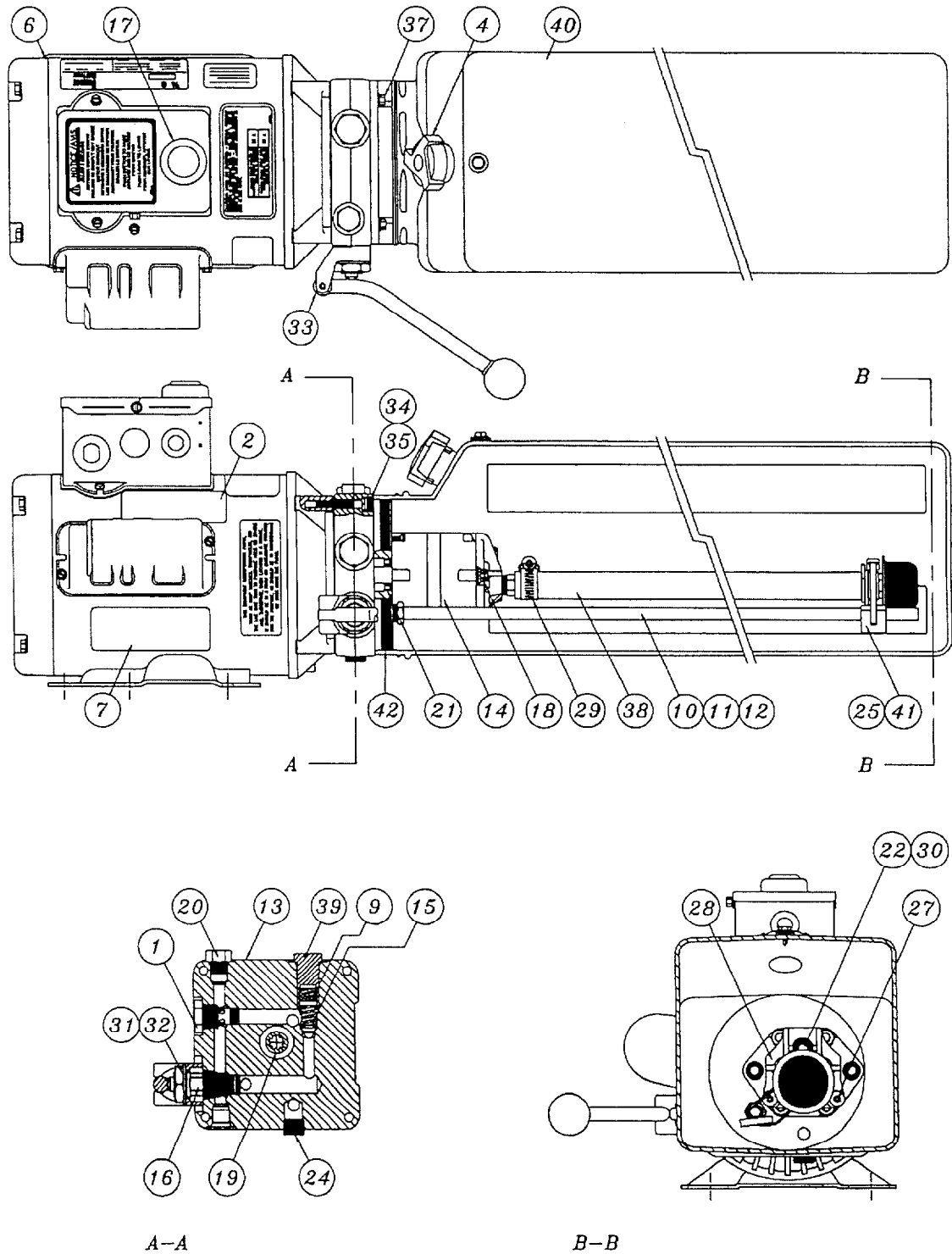

POWER PACK PARTS LIST: #6-2055 (AB-1381) 208-230V/1PH/60Hz

| ITEM | QTY. | DESCRIPTION | PART # |
|------|------|---------------------------------------|--------|
| 1 | 1 | VALVE CARTRIDGE CHECK | 6-1087 |
| 2 | 1 | LABEL INSTALLATION AUTOHOIST | 6-2136 |
| 4 | 1 | BREATHER CAP & BLADDER | 6-1376 |
| 6 | 1 | MOTOR AC 208-230V. 2HP/1PH/60Hz, BLK | 6-2139 |
| 7 | 1 | LABEL WARNING AUTOHOIST | 6-2149 |
| 9 | 1 | SPRING 0.480" x 0.063" x 0.42" COMP | 6-2151 |
| 10 | 1 | RETURN HOSE 3/8" OD x 21.5" | 6-2152 |
| 11 | 1 | COMPRESSION TUBE NUT | 6-2153 |
| 12 | 1 | COMPRESSION TUBE SLEEVE | 6-2154 |
| 13 | 1 | ENDHEAD UNIVERSAL AUTOHOIST | 6-2155 |
| 14 | 1 | PUMPASSY 2.5 CC/REV. SHORT SPLINE | 6-1958 |
| 15 | 1 | RELIEF ASSEMBLY FIXED 190 BAR | 6-1319 |
| 16 | 1 | VALVE CARTRIDGE RELEASE MANUAL | 6-0880 |
| 17 | 1 | WIRING ASSEMBLY AC 1PH FENNER | 6-2156 |
| 18 | 2 | BOLT 5/16"-24 x 3.00" TORX G8 | 6-1090 |
| 19 | 1 | COUPLING SAE 9T-20/40 1.260" | 6-0774 |
| 20 | 1 | PLUMBING PLUG 9/16" SAE | 6-2157 |
| 21 | 1 | SEAL SHAFT 0.500" x 1.00" x 0.25" | 6-2158 |
| 22 | 1 | WASHER 0.338" x 0.625" x 0.060" STEEL | 6-2159 |
| 24 | 1 | PLUMBING PLUG 3/8" NPT | 6-2161 |
| 25 | 1 | PLUMBING MAGNET | 6-2162 |
| 27 | 2 | SCREW TAPTITE M6 x 1.0 12MM TORX | 6-2164 |
| 28 | 1 | COVER ASSY SUCTION | 6-2165 |
| 29 | 1 | PLUMBING CLAMP HOSE ADJ. INLET | 6-2166 |
| 30 | 1 | BOLT 5/16"-18 x 1.00" SHCS | 6-1392 |
| 31 | 1 | NUT 3/4"-16 x 1" HEX x 0.250" STEEL | 6-2167 |
| 32 | 1 | WASHER 3/4" INT. TOOTH LOCK | 6-2168 |
| 33 | 1 | BRACKET - HANDLE ASSY REL BLACK | 6-0776 |
| 34 | 4 | BOLT M6 x 1.0 35MM SOC HD | 6-2169 |
| 35 | 4 | WASHER 1/4" LOCK HI-COLLAR | 6-2170 |
| 37 | 4 | BOLT #12-24 x 0.50' HEX WSHRHD | 6-1091 |
| 38 | 1 | PLUMBING ASSY INLET 17.24 (3) | 6-0786 |
| 39 | 1 | RELIEF VALVE CAP ASSEMBLY | 6-1089 |
| 40 | 1 | TANK PLASTIC 6.7 OS 22.50" BLK | 6-1399 |
| 41 | 1 | CABLE TIE 8" LONG WHITE | 6-1846 |
| 42 | 1 | O-RING 2-348 BUNA | 6-0875 |

LIFT MAINTENANCE GUIDELINES – HYDRAULIC EQUALIZATION

Two Post Lifts

Safety Instructions

Read operating and safety manuals before using any lift
Do not operate a lift that has been damaged or is in disrepair
Proper inspection and maintenance is necessary for safe operation

General

Check all hydraulic lines and fittings for pinch points , damage , cracks or leaks
Check all electrical wiring for pinch points , cracks or damage
Check all moving parts for uneven or excessive wear
Repair or replace all damaged , defective , worn or broken components immediately

Hydraulically Equalized Two Post Lift

- check and adjust hydraulic level weekly or as required
- clean and re-grease slide block channels inside of both columns every two months
- grease arm pins every two months
- check and lubricate safety dogs and safety cable adjustment every two months
- check arm restraints and lubricate every four months
- dismantle and clean inner arms every four months
- change hydraulic fluid every two years
- periodically check anchor bolts and re-torque if required

Lubrication : Where grease is required > multi-purpose lithium grease
Where lubricating oil is required > multi-purpose SAE 30 lubricating oil
Where hydraulic oil is required > ISO 32 10W - non detergent hydraulic oil