

ACCU TURN
BRAKE LATHE SYSTEM
MODEL 8920
OPERATIONS AND MAINTENANCE MANUAL

PAGE

3	List of Standard Accessories Included in the 8920
3	Brake Lathe Specifications
4	Acceptance from Carrier
4-8	Safety Information
9	Setting Up Brake Lathe for Operation
10-13	Operation Procedures Inspection Drums or Rotors
14-16	Diagrams
17-22	Parts List
23-32	Additional Diagrams

When ordering parts contact your
Local distributor, give Serial # of your
Machine and the date purchased; this
Will help in expediting your order.

For Records and Information:
Date Recv _____
Serial # _____
Rep Name _____

CONGRATULATIONS ... You have just purchased the finest brake lathe in the world today. Your ACCU-Turn Lathe is a high quality, precision engineered product designed to give you years of trouble free service.

To familiarize yourself with all its features, please take the time to **Read This Owner's Manual Carefully**. Store this manual in a safe place for future reference.

It is important that you **Fill Out The Enclosed Warranty Card and Mail It Back to our Headquarters**. This is of primary importance for authorization of warranty service, for proper parts shipments to match the model of your machine, and for receiving future product updates and information.

It is also important that you **Record the Model Number, Serial Number and Other Vital Information Here**. These numbers are located on the back of your lathe.

Dealer _____ Purchase Date _____

Model _____ Serial Number _____

STANDARD ACCESSORIES INCLUDED WITH THE 8920 COMBINATION BRAKE LATHE

- 1 Draw Bar with Hex Nut and Washer
- 1 T-Bolt with Nut and Washer
- 1 Spacer Block for Twin Cutter Attachment
- 2 Large Bell Clamps
- 2 Small Bell Clamps
- 3 Centering Cones
- 3 Silencers
- 5 Double Taper Radius Adapters
- 1 Twin Cutter with Tool Holders
- 1 Boring Bar with Tool Holder
- 1 Standard 1" Arbor
- 1 Arbor Nut
- 1 Arbor Spring
- 1 1" Spacer
- 1 Set of Alignment Washers
- 3 Wrenches 1 1/2", 7/8", 3/8"

8920 COMBINATION BRAKE LATHE SPECIFICATIONS

115 Volt	50-60 --- Hertz	1 Phase	15 Amps
Rotor Capacity -----	4" to 24"		
Maximum width of surface -----	4 1/2"		
Maximum thickness -----	2 1/4"		
Drum Capacity -----	6" to 28"		
Friction Surface Capacity -----	6"		
Maximum Weight:			
On 1" Arbor -----	150 lbs.		
Spindle Speed RPM -----	177		
Feeds Per Spindle Revolution:			
Disc -----	.0024		
Drum -----	.0024		
Motor -----	1/2 Horsepower		
Weight:			
Net -----	469 lbs.		
Ship Wt. -----	539 lbs.		

ACCEPTANCE FROM TRANSPORTATION CARRIER

Carefully inspect all items received in this shipment. If there is damage or evidence of mishandling in transit, determine the extent of damage and notify the transit company as well as ACCU Industries, Inc. immediately. Although we are not responsible for damage incurred in transit, we will assist in the preparation and filing of claims.

SAFETY INFORMATION

This manual has been prepared for the operator and those responsible for the maintenance of the brake lathe. Its purpose, aside from proper maintenance and operations, is to promote safety through the use of accepted practice.

READ AND UNDERSTAND THE SAFETY AND OPERATING INSTRUCTIONS COMPLETELY BEFORE OPERATING THE MACHINE

In order to obtain maximum life expectancy and efficiency from your brake lathe, follow the operating instructions and maintenance manual carefully.

The specifications put forth in this manual were in effect at the time of publication. However, owing to ACCU Industries' policy of continuous improvement, changes to the specifications may be made at any time without obligation on the part of ACCU Industries, Inc.

Safety Instructions

1. Read, understand and follow the safety and operating instructions found in this manual. Know the limitations and hazards associated with operating the machine. A safety rules decal is installed on the machine to serve as a reminder of basic safety practice. It should be read before attempting to use the brake lathe.
2. Special Precautions: This ACCU-Turn brake lathe was designed to machine the portions of the brake drum and disc brake rotor surfaces that come in contact with the friction material. When used according to the instructions herein, this lathe will perform satisfactorily within the workpiece size range designated for this model.

During the machining operation, the workpiece rotates. Be especially cautious of rotating wheel lugs, spokes and mounted accessories. During machining, material removal may

cause a sharp edge to be generated, where a chamfer or radius previously existed. Use care in handling machined parts.

3. Securing the Machine: The model 8920 weighs approximately 470 pounds and must be bolted to an ACCU-TURN Heavy duty Floor Stand or a bench capable of supporting the machine, its accessories and workpiece.
4. Grounding the Machine: In the event of a malfunction or breakdown, grounding provides a path of least resistance for electric current to reduce the risk of electric shock. The lathe is equipped with an electric cord having an equipment-grounding conductor and a grounding plug. The plug must be plugged into a matching outlet that is properly installed and grounded in accordance with all local codes and ordinances.

Do not modify the plug provided. If the plug will not fit the outlet, have the proper outlet installed by a qualified electrician.

Improper connection of the equipment-grounding conductor can result in a risk of electric shock. The conductor with insulation having an outer surface that is green with or without yellow stripes is the equipment-grounding conductor. If repair or replacement of the electric cord or plug is necessary, do not connect the equipment-grounding conductor to a live terminal.

Check with a qualified electrician or service personal if the grounding instructions are not completely understood, or if in doubt as to whether the lathe is properly grounded.

Use only 3-wire extension cords that have 3-prong grounding plugs and 3-pole receptacles that accept the lathe's plug.

Repair or replace damaged or worn cord immediately.

This lathe is intended for use on a circuit that has an outlet that looks like the one illustrated in Sketch A in Figure 4.1. The tool has a grounding plug that looks like the plug illustrated in Sketch A in Figure 4.1. A temporary adapter, which looks like the adapter illustrated in Sketches B and C, may be used to connect this plug to a 2-pole receptacle as shown in Sketch B if a properly grounded outlet is not available. The temporary adapter should be used only until a properly grounded outlet can be installed by a qualified electrician. The green-colored rigid ear, lug, or other grounding means. extending from the adapter must be connected to a permanent ground such as a properly grounded outlet box.

5. Use Proper Extension Cord: Make sure your extension cord is in good condition. When using an extension cord, be sure to use one heavy enough to carry the current the lathe will draw. An undersized cord will cause a drop in line voltage resulting in a loss of power and overheating. Table 5.1 shows the correct size to use depending on the cord length. If in doubt, use the next heavier gage. The smaller the gage number, the heavier the cord.
6. Eye Safety: Wear an approved safety face shield, goggles, or safety glasses. (Ordinary eyeglasses are not safety glasses and do not provide the degree of protection necessary.) If the operation or area is dusty a face or dust mask should be used.
7. Personal Protection: Before operating the machine, remove tie, rings, watches, and other jewelry, and roll up sleeves above the elbow. Remove all outer loose clothing and confine long hair. Protective type footwear must be worn. Hearing protectors must be used where noise exceeds the level of exposure allowed in Section 1910.95 of the OSHA Regulations.

DO NOT WEAR GLOVES

8. DO NOT OPERATE MACHINE WITHOUT ITS GUARD(S) IN PLACE AND IN WORKING ORDER.
9. Do Not Use Lathe in Dangerous Environment: Don't use the lathe in damp or wet locations, or expose the lathe to rain. Keep the work area well lighted.
10. Work Area: Keep the floor around the machine clean and free of foreign materials. ACCU Industries recommends the use of anti-skid floor strips where the operator normally stands, and that each machine has its own work area marked off. Make certain that the work area is well-lighted and ventilated. Provide for adequate work space around the machine. The work area should not be readily accessible to anyone except the operator.
11. Do Not Overreach: Maintain a balanced stance and keep your body under control at all times.
12. Hand Safety: Keep hands away from moving parts when the machine is under power. Never clear chips or debris when the machine is under power and never use your hands to clear the chips. Never use compressed air to clean machine; use only a soft bristle brush or vacuum cleaner.
13. Spindle Rotation: Rotate spindle by hand before applying power. Be sure that the rotation of the spindle is correct.

14. Machining Preparation: Tighten all locks before operating the lathe. Be sure workpiece is secured. Remove adjusting keys and wrenches. Be sure to check to see that all adjusting wrenches are removed from the lathe before turning the machine on.
15. Check Damaged Parts: Before further use of the lathe, a guard or other part that is damaged should be carefully checked to determine if it will operate properly and perform its intended function. Check for alignment of moving parts, binding of moving parts, breakage of parts, mounting, and any other conditions that may affect the lathe's operation. A guard or other part that is damaged should be properly repaired or replaced.
16. Maintain Tools with Care: Keep tools sharp and clean for best and safest performance. follow instructions for lubricating and changing accessories.
17. Avoid Accidental Starting: Make certain that the motor switch is in the "Off" position before connecting power to the machine.
18. Never Stand on Lathe: Serious injury could occur if the lathe is tipped or if the cutting tool is unintentionally contacted.
19. Machine Capacity: Do not attempt to use the machine for other than passenger car and light truck drums and rotors, or for operations for which the machine was not intended.
20. Careless Acts: GIVE THE WORK YOU ARE DOING YOUR UNDIVIDED ATTENTION.
21. Disconnect Electrical Power before performing any service, maintenance, or changing of accessories, adapters, or workpieces on machine.
22. Job Completion: If the operator leaves the machine area for any reason, the machine should be turned off, and the spindle brought to a complete stop before the operator departs. In addition, if the operation is complete, the operator should clean the machine and work area. NEVER CLEAN THE MACHINE WITH THE POWER ON.
23. Replacement Parts: Use only ACCU-TURN replacement parts and accessories, risk of injury may result if accessories other than those recommended are used. USE OF PARTS OTHER THAN ACCU-TURN PARTS WILL VOID THE WARRANTY.

24. Misuse: Do not use the machine for other than its intended use. If used for other purposes, ACCU Industries Inc., disclaims any expressed or implied warranty, and holds itself harmless for any injury or loss that may result.

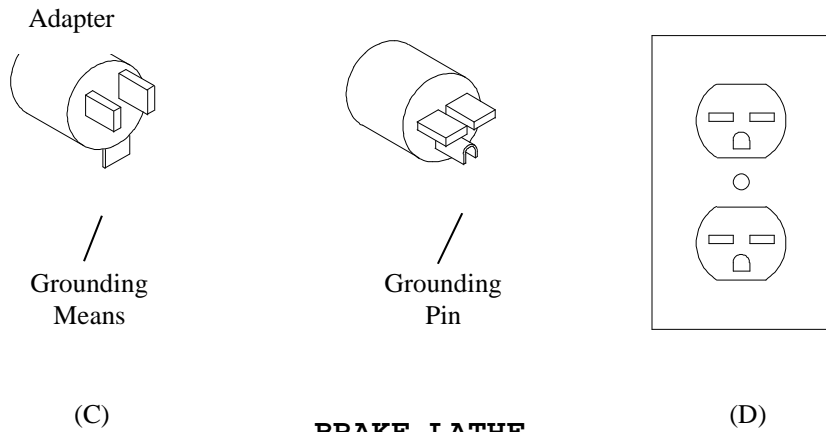
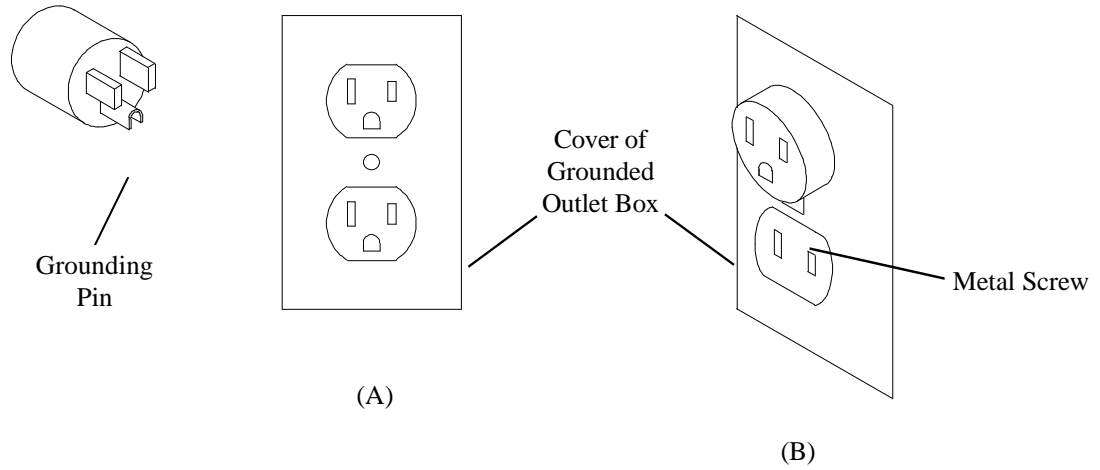

ASSEMBLY OF

BRAKE LATHE

Fig. 4.1

Amper Rating	Volts	Total length of cord in feet			
	120 V	25 ft.	50 ft.	100 ft.	150 ft.
More Than	Not More Than	AWG			
12	16	14	12	Not recommended	

Table 5.1

Setting Up Brake Lathe For Operation

All machined surfaces are covered with a protective coating before packaging. They must be thoroughly cleaned with solvent. The spindle, arbor taper and mounting surface on top of ways must be cleaned and wiped dry.

Install the draw bar in the arbor. Insert the draw bar through the spindle, and align the match marks on the arbor and spindle. Install the washer and nut on the rear of the draw bar, and tighten to 55 foot pounds. Mount the drum boring bar or rotor twin cutter on the machine; make sure all inserts, bolts, and set screws are tight.

Machine must be securely fastened to work bench surface before operating. Four mounting holes on the base are provided for this purpose.

Lubrication

Lubricate ways by oiling felt wipers on the end of cross slide every week with SAE 10W oil or equivalent, and check gear box by removing vented plug on top rear of housing. Oil level should be about 2 inches from the top. If needed, use MOBIL Synthetic Gear Oil - SHC 634 (ACCU-Turn #430866). Capacity is one quart. DO NOT OVER-FILL.

Electrical Information

Standard motors on this machine are wired to 115 volt, 60 cycle, single phase. Check electrical input plate on rear of machine. The Off-On switch is located to the right end of the main housing. Never operate machine unless power supply agrees with electrical plate rating and machine is properly grounded.

ACCU-TURN 8920 COMBINATION BRAKE LATHE

OPERATION PROCEDURES

Inspection of Brake Drums and Disc Rotors Before Machining

IMPORTANT: The maximum amount of metal removed from the finished workpiece should never exceed the manufacturer's specifications. It is dangerous to operate a vehicle with a drum or rotor which has had more material removed than is allowed. Proper operation cannot be established if these specifications have been exceeded. ACCU Industries recommends that each workpiece be checked for size before mounting on the lathe and after machining.

Mounting Hubless Drums or Rotors

1. Clean and check all surfaces for flatness that will come in contact with centering cones and/or bell clamps to ensure solid mounting.
2. Cleaning and properly mounting the drum or rotor prior to machining will ensure a minimum of stock removal, better surface finish and optimum braking efficiency.
3. Excessive run out or wobble of the drum or rotor after it has been properly cleaned and mounted on the arbor may indicate severe damage to the drum or rotor. These drums or rotors should not be used for further service.
4.
 - a. Select proper size bell clamps and slide one on the arbor.
 - b. Slide spring on the arbor.
 - c. Find the centering cone adapter that fits the center hole of the drum or rotor and slide it on the arbor.
 - d. Slide the drum or rotor on the arbor and then the other bell clamp.
 - e. Add necessary spacers (double tapered radius adapters may be used as spacers), alignment washers (make sure they are installed concave to convex), hex nut and tighten securely. Do not jerk or over tighten. (See example on page 15)
5. WRAP RUBBER SILENCER BAND AROUND DRUM, STARTING WITH THE PLAIN END AND MAINTAIN TENSION UNTIL THE CLIP IS SECURED. DO NOT ATTEMPT TO MACHINE DRUMS WITHOUT USING THE SILENCER BAND. Silencer should be nearest open side of drum. Silencers should also be used for rotor machining.

6. If arbor appears distorted, check for rust, burrs or chips on cones, drum or rotor, bell clamps, spacers, arbor or other mating surfaces.
7. Composite hubless rotors may require optional composite rotor adapters.

Mounting Hubbed Drums or Rotors

1. Select the double tapered radius adapter that properly fits the inside of the large bearing race. It should sit in the race similar to a bearing and move side to side in all directions easily. If it binds in any direction, this is an indication of an incorrect adapter selection or a damaged bearing race. Correct problem before proceeding.
2. Slide the double tapered radius adapter all the way onto the arbor. If the drum or rotor contacts the lathe, a spacer may be required between the double tapered adapter and lathe.
3. Using the same procedure as in Step 1, select the double tapered radius adapter for the outside race.
4. Install the drum or rotor and position it on the back double tapered radius adapter and then slide the front double tapered radius adapter on the arbor and into the front race.
5. Use adapters or spacers as necessary to space out to the end of the arbor. (See example on page 15) Double tapered radius adapters may be used as spacers. Add alignment washers (make sure they are concave to convex) and hex nut then tighten. Do not shock load, jerk or over tighten.
6. WRAP RUBBER SILENCER BAND AROUND DRUM, STARTING WITH THE PLAIN END AND MAINTAIN TENSION UNTIL THE CLIP IS SECURED. DO NOT ATTEMPT TO MACHINE DRUMS WITHOUT USING THE SILENCER BAND. Silencer should be nearest open side of drum. Silencers should also be used for rotor machining.
7. If arbor appears distorted, check for dirty or damaged mounting surfaces and/or adapters. Loosen and re-tighten arbor nut as described above in Step 5.

Machining Hubless and Hubbed Drums

1. Position the boring bar so that the 45 degree angle tool bit slot is toward the drum, with the capscrew to the top. BORING BAR EXTENSION SHOULD BE KEPT TO A MINIMUM. Boring bar must not be rotated upward or downward.

2. For extra small diameter drums, set the boring bar at an angle towards the arbor while extending the boring bar outward from the boring bar holder.
3. Turn on the machine. Slowly advance the boring bar in the drum and contact the point of the greatest wear.
4. Note the reading on the calibrated handwheel; back out one full turn and move to the rear of the drum.
5. Set handwheel to .005 deeper than the noted reading; this will ensure a finished drum in one cut.
6. Engage the cross-feed handle for the drum slide with the ON-OFF switch to drum position.

Machining Hubless and Hubbed Rotors

1. The twin cutter must be positioned in proper alignment with the rotor. Center the disc rotor between the two tool bar holders. The tool bars are fed by calibrated knobs at either sides of the bars.
2. With machine running, set the tool bars for depth of cut by loosening the locking screw on top of the tool bars so that the bars will move freely when the calibrated knobs are turned.
3. Adjust cutter bars to remove the minimum amount required to finish the rotor in one cut. DO NOT MACHINE A ROTOR TO LESS THAN MANUFACTURER'S SPECIFICATIONS.
4. If surface is scored, locate the deepest score and turn the rotor micrometer knob until the tool bit bottoms out at the deepest point of the score; zero the scale and back out the tool bit. Repeat on other side. If no score exists, touch rotor with tool bit near outer edge and advance calibrated hand knob until full circle is scratched on rotor and "0" knob. Back out the tool bit.
5. Advance the twin cutter by handwheel until the tool bits have cleared the inner edge of the rotor face. Adjust the micrometer knobs for approximately .005 more than the first reading. This will ensure finishing the rotor in one cut. Some rotors may require optional "Zero" angle tool holders.
6. Tighten locking screws. IT IS NOT NECESSARY TO TIGHTEN THESE SCREWS EXCESSIVELY.

The replacement carbide inserts have three cutting surfaces. When sufficient wear causes an inferior finish, rotate the carbide insert to a new tip. There is a precision relief below the cutting edge. DO NOT TURN THESE INSERTS OVER.

FOR INFORMATION ON SPECIAL APPLICATIONS, CONTACT YOUR
ACCU-TURN DISTRIBUTOR OR CALL ACCU INDUSTRIES AT
(804)798-8922

Sharp Tools Are Vital To Satisfactory Operation

When ordering supplies or replacement parts for this machine, always give the model # and serial # of the machine. Use only ACCU-TURN parts.

PROPER MOUNTING OF HUBLESS ROTOR OR DRUM

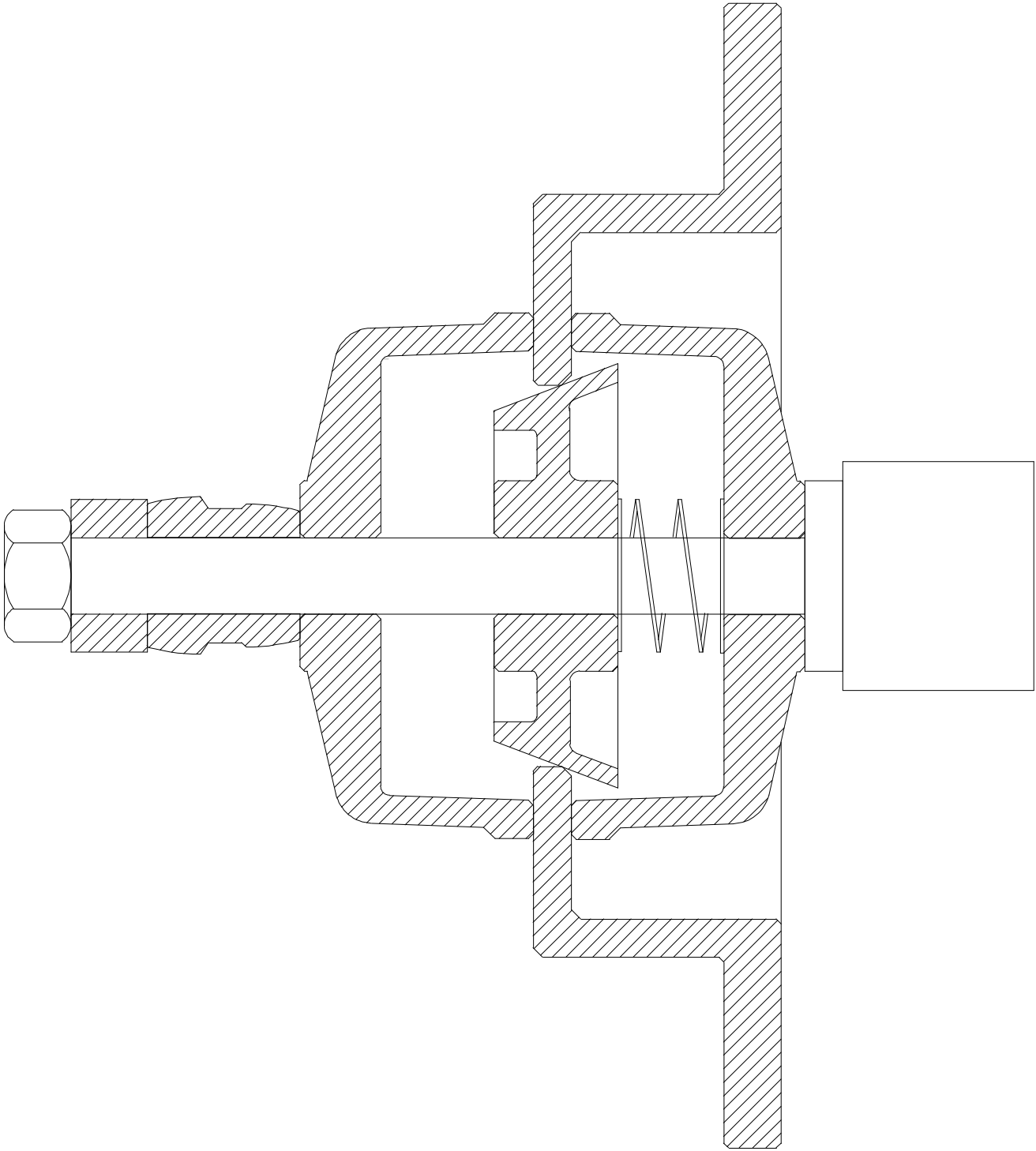

PROPER MOUNTING OF HUBBED ROTOR OR DRUM

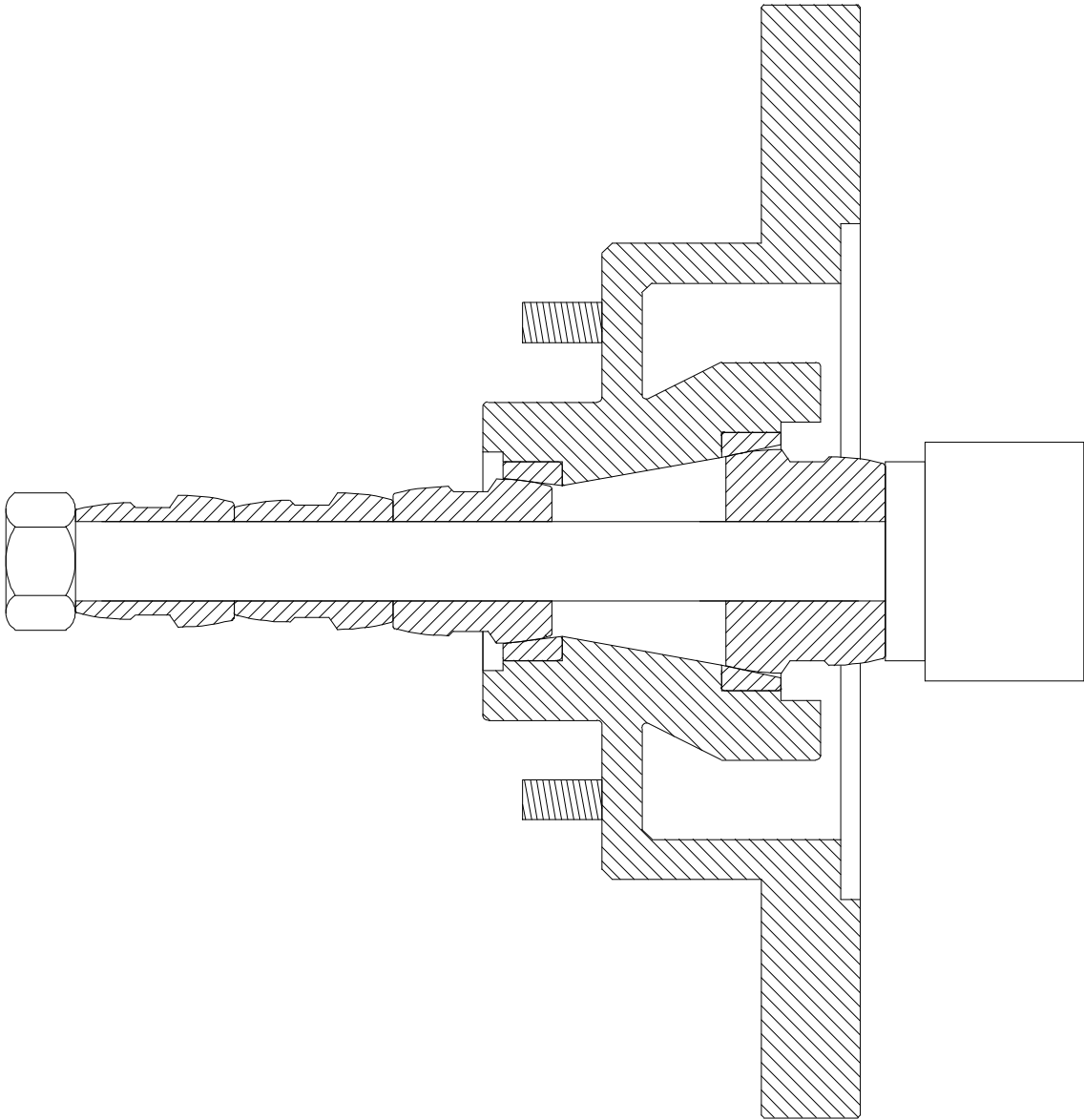

SEALED BEARING MOUNTING

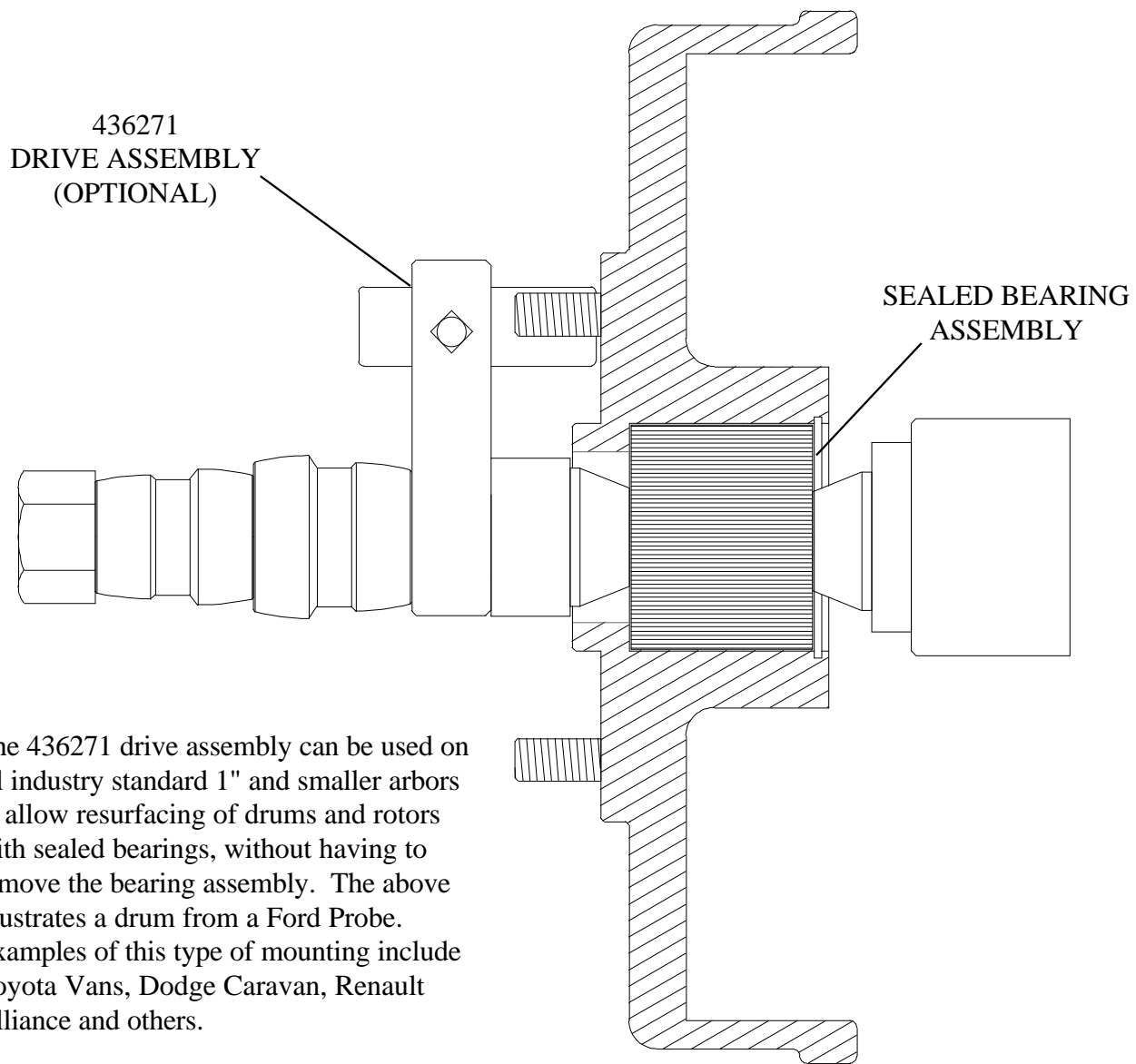

The 436271 drive assembly can be used on all industry standard 1" and smaller arbors to allow resurfacing of drums and rotors with sealed bearings, without having to remove the bearing assembly. The above illustrates a drum from a Ford Probe. Examples of this type of mounting include Toyota Vans, Dodge Caravan, Renault Alliance and others.

8920 COMBINATION BRAKE LATHE

PARTS LIST

ITEM #	PARTS #	QTY. REQ'D.	DESCRIPTION
1	434013	1	HOUSING
2	434014	1	COVER, HOUSING
3	434420	1	GASKET .015
4	420772	4	SCREW
6	433605	1	SPINDLE
7	433618	1	BEARING, CONE
8	433619	1	BEARING, CUP
9	433616	1	BEARING, CONE
10	433772	1	BEARING, CUP
11	433622	1	SEAL
12	431146	1	SEAL
13	433620	1	SEAL
14	408129	1	SEAL
15	433611	1	SHIM
16	433612	1	SHIM
17	433613	1	SHIM
18	411342	1	KEY
19	435254	1	GEAR, WORM
20	433974	1	SCREW, SET
21	408365	1	LOCK WASHER
22	408364	1	LOCK NUT
23	440134	1	SHAFT, WORM
24	433614	2	BEARING, CONE
25	433615	2	BEARING, CUP
26	433608	1	CARRIER, BRG.
27	421643	1	GASKETS
28	411389	4	SCREW
29	420149	1	SEAL
30	433628	1	DOVE TAIL, BOTTOM
31	433634	4	SCREW
32	433790	2	WEAR STRIP ASSY.
33	433635	1	WAY WIPER ASSY.TOP
34	433638	10	SCREW
35	433629	1	DOVE TAIL,CENTER
36	433627	1	DOVE TAIL, TOP
37	433630	8	SCREW, SET
38	413294	8	WASHER
39	413291	8	NUT, HEX
40	433639	2	SCREW, TURN
41	433157	2	SCREW, FEED ASSY.
44	435586	4	PIN

ITEM #	PARTS #	QTY. REQ'D.	DESCRIPTION
45	432413	4	BOLT, WASHER HEAD
47	433623	2	BEARING, BALL
48	433907	2	HOUSING, FEEDBOX
49	433646	2	NUT, FEED
51	411378	4	SCREW
52	417258	2	SCREW
53	433641	2	MOTOR 1/60, 6 RPM
54	434081	6	SCREW
55	434384	2	ASSY. SHIFTING YOKE
56	434016	2	COLLAR
57	421431	2	KEY
58	434439	2	DRIVE ADAPTER
59	433974	2	SCREW, SET
60	433653	2	GEAR, SPUR 55 TEETH
61	433655	2	SPRING, CONICAL
62	433654	2	WASHER
63	421077	2	RING, RETAINING EXT.
64	433651	2	GEAR, SPUR 70 TEETH
65	433649	2	SWITCH, LIMIT
68	433908	2	COVER, FEEDBOX HSING
69	434017	2	SNAP-IN NYLINER
70	433909	2	HANDLE, SHIFTER
71	433974	8	SCREW, SET
72	1A2169	2	SPRING
73	408373	2	BALL
74	433667	1	GUARD, RTR WAY MTR
75	433677	1	GUARD, DRM WAY MTR
76	433638	4	SCREW
77	433735	2	TELESCOPING WAY COVER ASSY.
78	433648	12	SCREW
79	433682	4	SPACER, WAY COVER
80	433688	4	SCREW
81	433687	4	SCREW
82	433828	1	HANDWHEEL ASSY. DRUM
82A	433665	1	HANDWHEEL
82B	433666	1	HANDLE, REVOLVING
82C	433669	1	DECAL, CAL 0-80 DRUM
82D	408409	1	SCREW
82E	433974	1	SCREW
83	433829	1	HANDWHEEL ASSY. ROTOR
83A	433665	1	HANDWHEEL
83B	433666	1	HANDLE, REVOLVING
83C	433781	1	DECAL, CAL 0-95 RTR
83D	408409	1	SCREW
83E	433974	1	SCREW, SET
84	433729	1	BASE, MOTOR ASSY.

ITEM #	PARTS #	QTY.	REQ'D.	DESCRIPTION
85	433626	1		SHAFT, MOTOR PVT.
86	434228	2		SCREW, SET
87	440130	1		MOTOR 115/230 VOLT 1 PHASE, 1/2 H.P.
88	434574	4		WASHER
89	434575	4		SCREW
90	436111	2		SHEAVE PULLEY
92	433673	1		V-BELT
93	433675	1		GUARD, BELT
94	433638	2		SCREW
96	433674	1		FITTING, VENT
97	413281	1		PLUG, DRAIN
98	430866	32 OZ		OIL, MOBIL SYNTHETIC GEAR OIL, SHC-634
99	433830	TRACE		STORE-AND-LUBE
100	411478	1 OZ		GREASE #2
101	433727	1		POWER CORD ASSY.
102	433726	1		MOTOR CORD ASSY.
103	433698	1		WIRE, ELECTRICAL
108	433719	5		CLAMP, CABLE 2 SCREW
109	436388	1		SLEEVING, ELECTRICAL
110	434133	8		CONNECTOR, CRIMP-ON
111/112	434132	2		CONNECTOR, CRIMP-ON
113	433818	1		SCREW
114	434402	1		SCREW
115	433693	1		SWITCH, TOGGLE
116	433695	1		DECAL, SWITCH
117	433732	1		LABEL, WARNING
118	433733	1		LABEL, WARNING
119	438170	1		NAMEPLATE, MODEL 8920
120	438175	1		NAMEPLATE, SERIAL #
121	433633	1		BOLT, T SLOT
122	433777	1		HOLDER, BORING BAR
123	4B4280	1		WASHER
124	433617	1		NUT, HEAVY HEX.
125	433778	1		BORING BAR
126	433780	2		SCREW, SET
127	433779	1		HOLDER, TOOL BIT
128	433771	1		SCREW, SET
129	433717	3		CARBIDE BIT & SCREW
130	434009	1		CAP PLUG
131	433974	4		SCREW, SET
132	434199	1		WAY WIPER ASSY. CTR.
133	434378	1		PATENT NUMBER PLATE
136	436267	2		SCREW, SET
137	436268	4		NUT

ITEM #	PARTS #	QTY. REQ'D.	DESCRIPTION
138	433994	2 oz	GREASE, EXXON LIDOK 000
139	434800	1	PLUG
140	436259	2	WAY WIPER KIT
NOT SHOWN	438059	2	SERVICE LABEL
NOT SHOWN	436408	2	WAYCOVER LABEL
NOT SHOWN	434225	1	6 1/2" SQUARE BOTTOM PLATE
NOT SHOWN	434226	1	4 X 16 1/4" BOTTOM PLATE
NOT SHOWN	433648	3	BOTTOM PLATE SCREW
184	437412	1	ACCESS COVER
185	433638	4	SCREW

433750 TWIN CUTTER ASSEMBLY (8920 ONLY)

PARTS LIST

ITEM#	PARTS#	QTY.	REQ'D.	DESCRIPTION
300	433752	1		BASE, TWIN CUTTER
301	433753	1		BASE, TENSION BAR
302	433754	1		BASE, POINTER
303	433755	1		TOOL HOLDER, R.H.
304	433756	1		TOOL HOLDER, L.H.
305	433757	1		TENSION BAR
306	433758	1		POINTER
307	433759	2		ADJUSTING WHEEL
308	433760	2		ADJUSTMENT SCREW
309	433761	2		CALIB. WHEEL R.T.
311	433763	1		TOOL BIT HOLDER R.H.
312	434286	1		TOOL BIT HOLDER ZERO ANGLE
314	433765	2		SCREW, SHOULDER
315	420212	1		SCREW
316	420211	1		SCREW
317	433766	2		SCREW
318	433767	2		SCREW, THUMB
319	433768	2		WASHER, WAVE
320	420772	2		SCREW, DRIVE
321	433770	1		SPRING
322	433771	2		SCREW, SET
323	434738	2		SPRING, BELVILLE
325	4B9806	4		SCREW, SET
326	433773	4		BALL, NYLON

STANDARD ACCESSORES

ITEM #	PARTS #	QTY. REQ'D.	DESCRIPTION
200	433702	1	BAR, DRAW
201	4B4280	1	WASHER
202	433617	1	NUT, HEAVY HEX.
203	433703	2	PLATE, FACE 1
204	433704	2	PLATE, FACE 2
205	433705	1	CENTERING CONE, DRUM #1
206	433706	1	CENTERING CONE, DRUM #2
207	433707	1	CENTERING CONE, DRUM #3
208	433708	1	ADAPTER #1
209	433709	1	ADAPTER #2
210	433710	1	ADAPTER #3
211	433711	1	ADAPTER #4
212	433617	1	NUT, HEAVY, HEX.
213	433712	1	SPACER, ARBOR
214	433715	1	WASHER, ASSY. SELF ALIGNING
215	433713	1	NUT, HEX.
216	433774	1	SPACER
217	433716	1	SPRING, ARBOR
218	433782	1	SILENCER, DRUM
219	433785	1	SILENCER, LG. VENTED ROTOR
220	433789	1	SILENCER, SMALL NON-VENTED ROTOR
221	436410	1	WRENCH, 1 1/2 BOX END
222	433963	1	ADAPTER #1-A
223	434558	1	WRENCH
224	434559	1	WRENCH
	433172	1	1" BORING BAR ASSEMBLY CONSISTS OF:
125	433778	1	BORING BAR
122	433777	1	BORING BAR HOLDER
128	433771	1	SCREW SET
127	433779	1	TIP HOLDER
126	433780	2	SCREW SET
129	433717	1	CARBIDE BIT & SCREW
	433750	1	RT GROUP (W/TOOL HOLDERS)

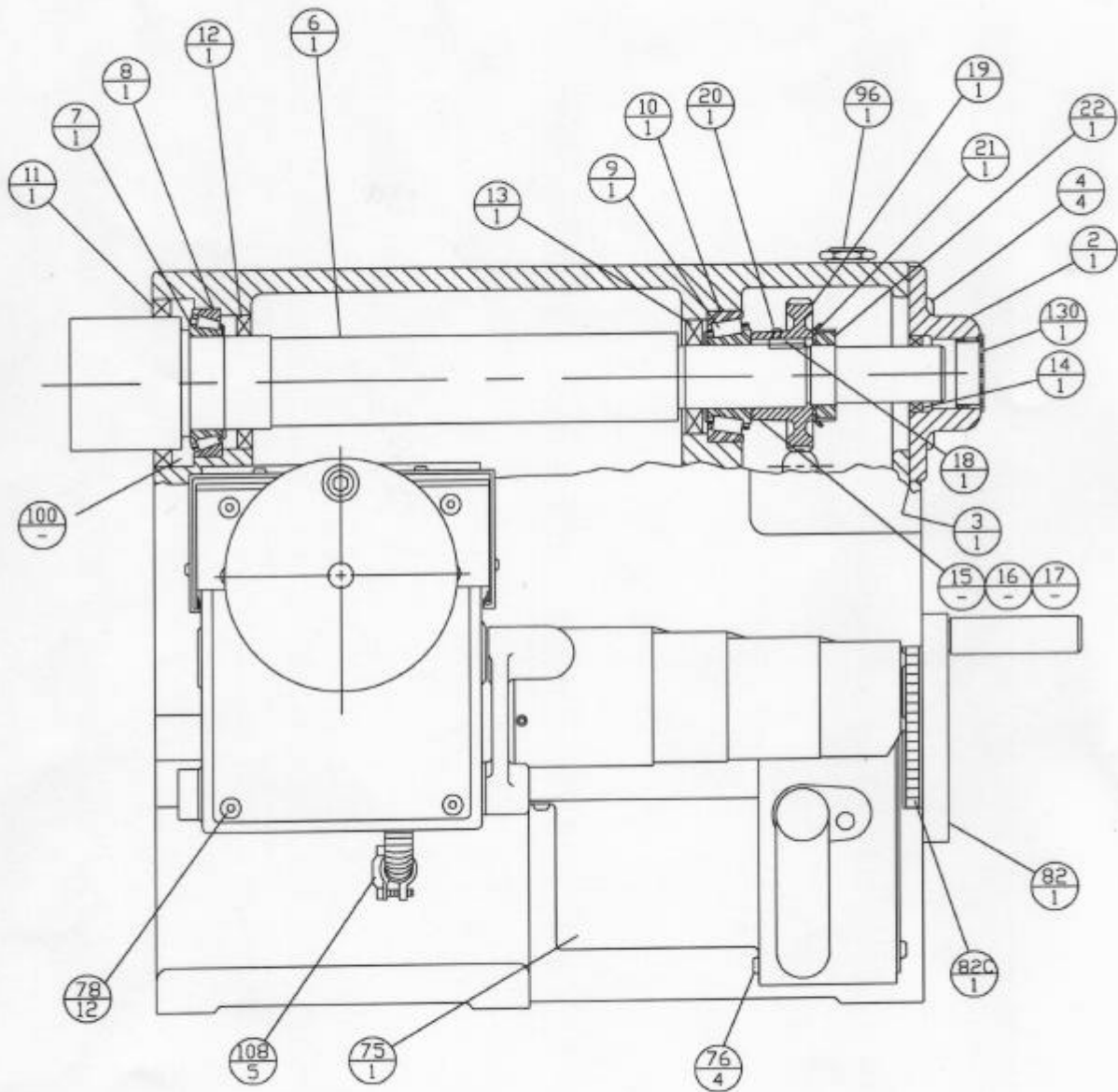

8920-1

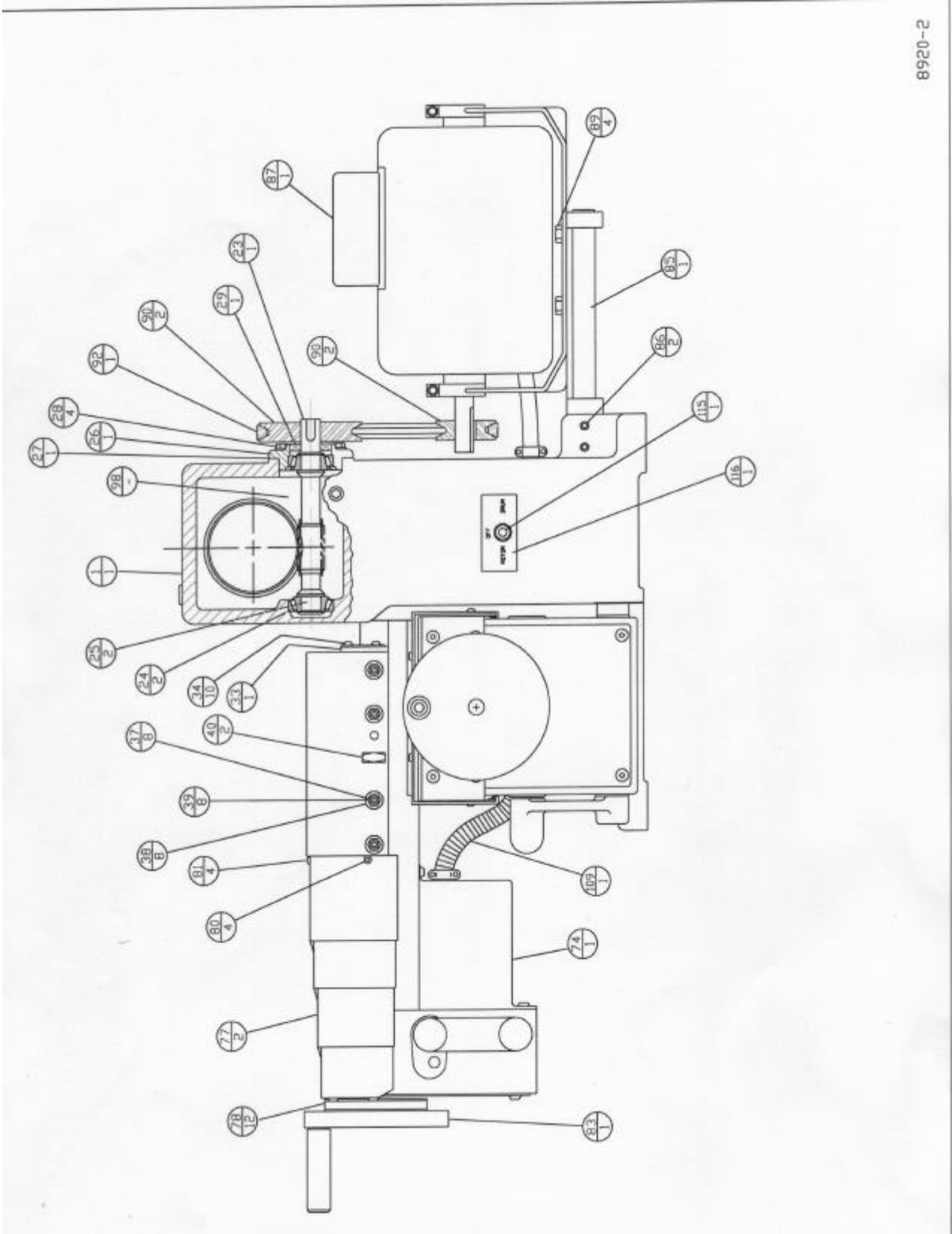

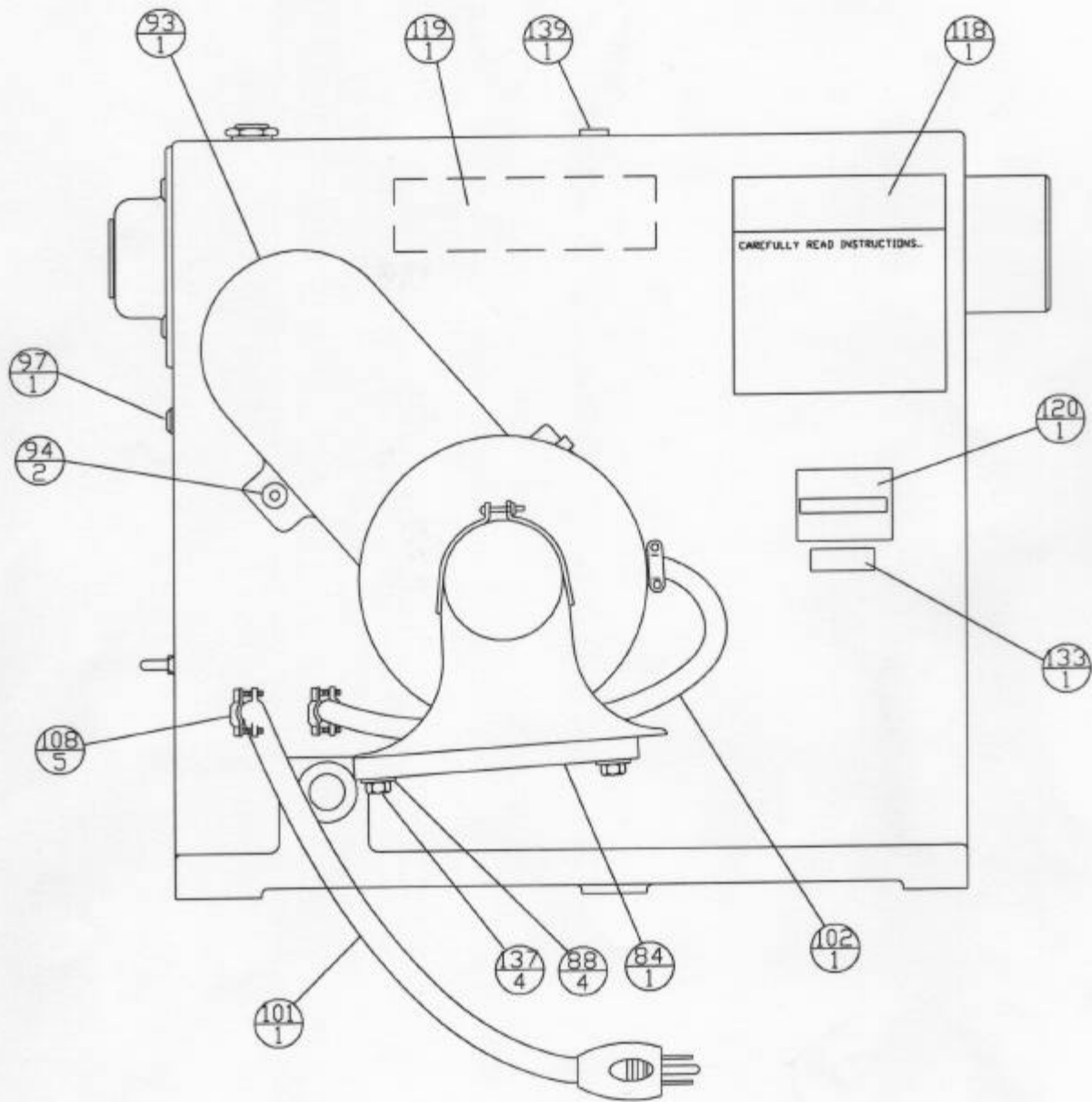

9820-3

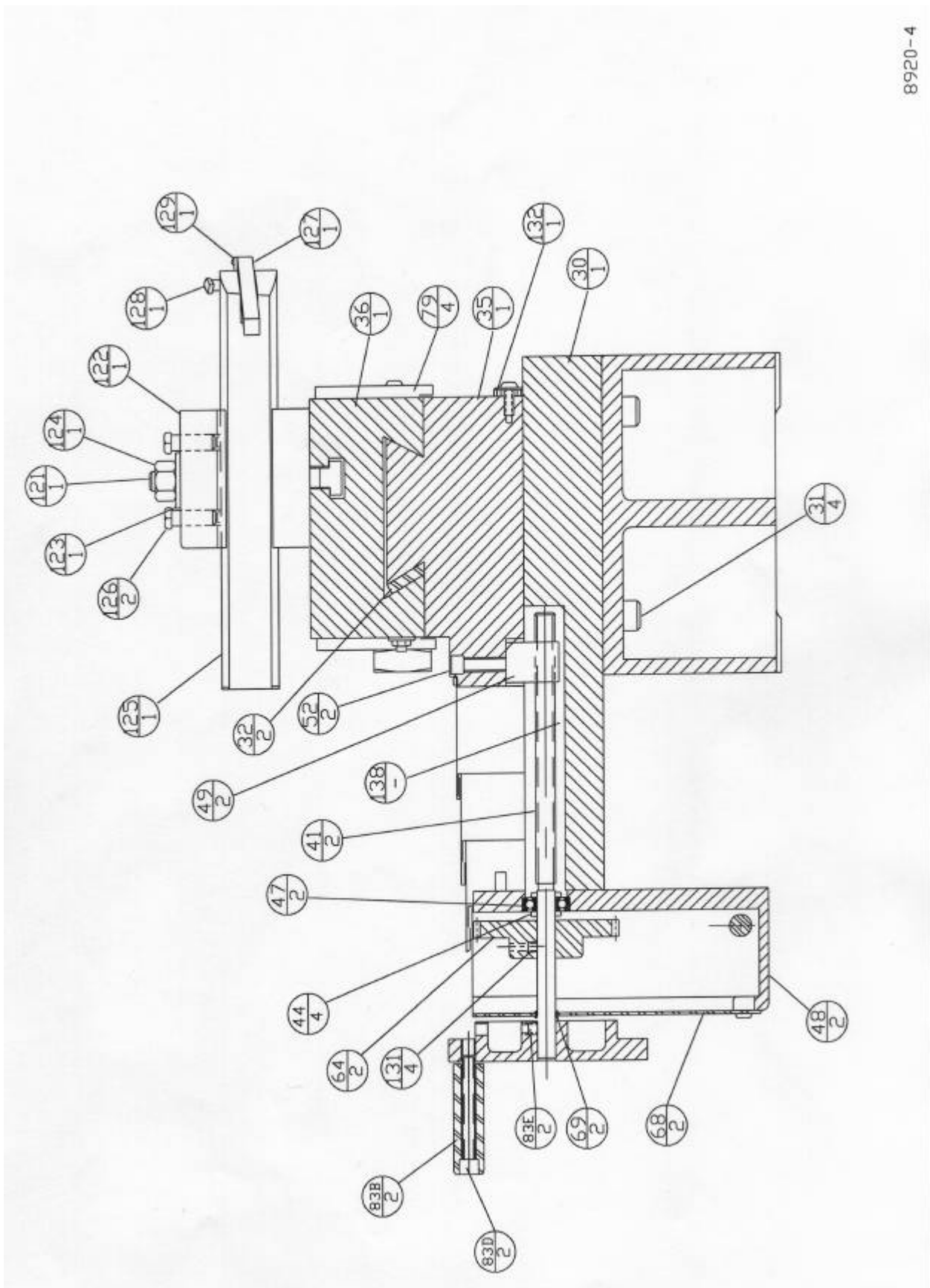

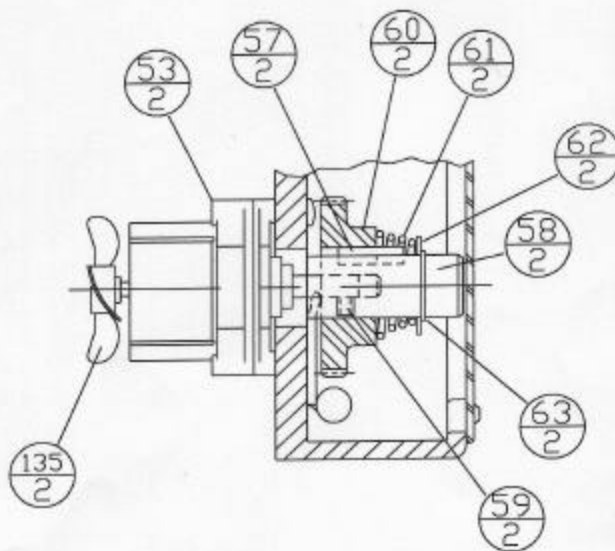
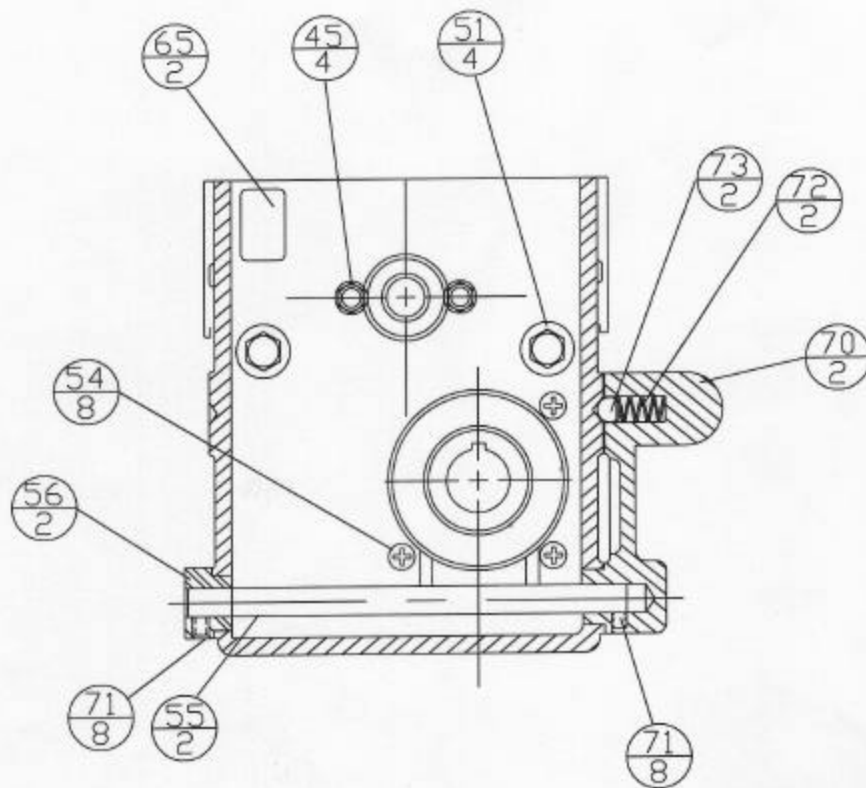

8920-5

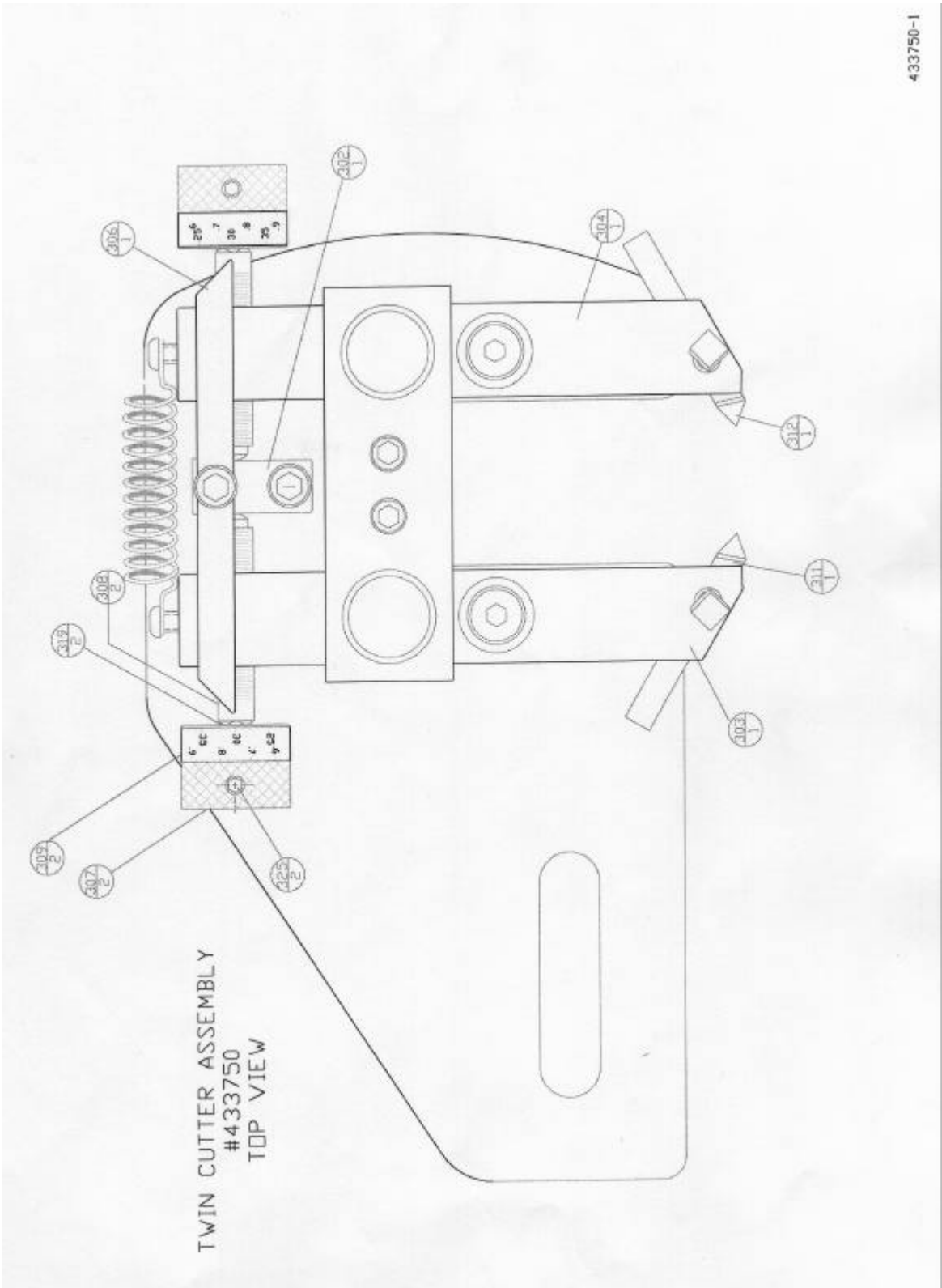

433750-1

TWIN CUTTER ASSEMBLY
#433750
FRONT VIEW

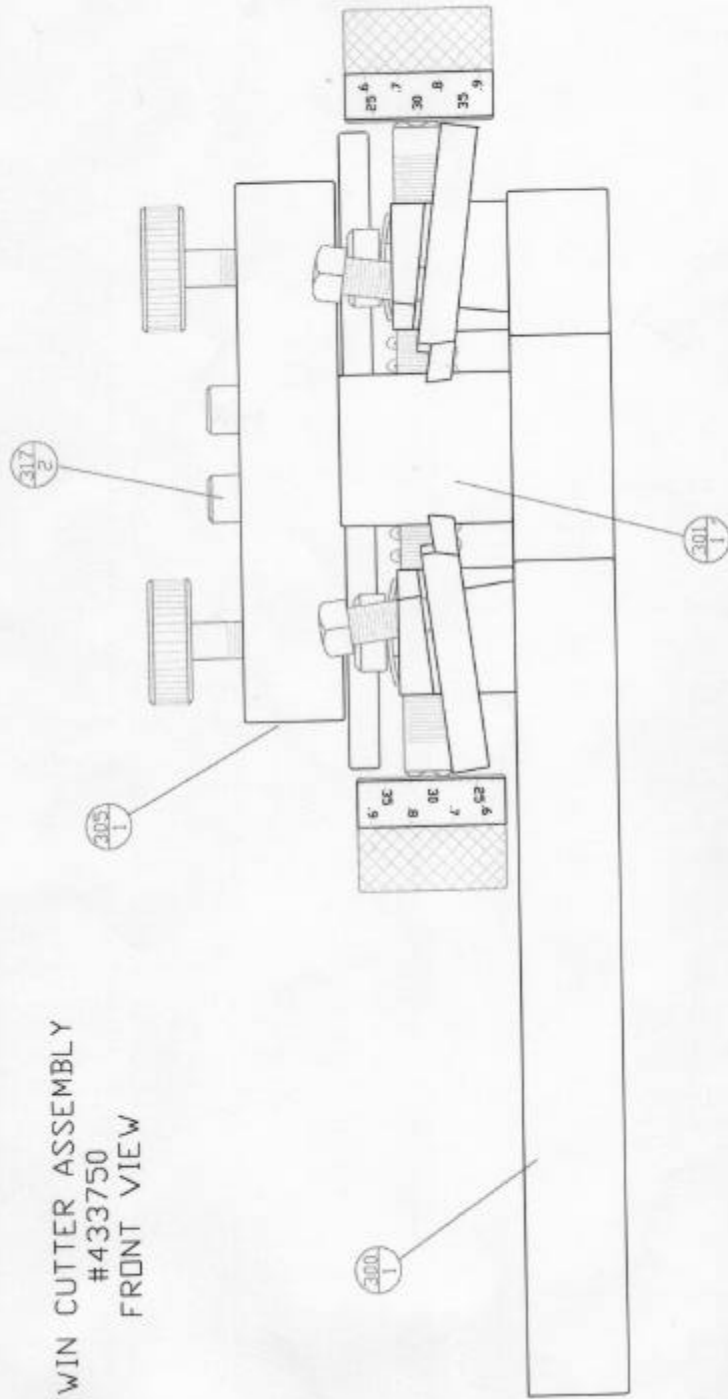

TWIN CUTTER ASSEMBLY
#433750
SIDE VIEW

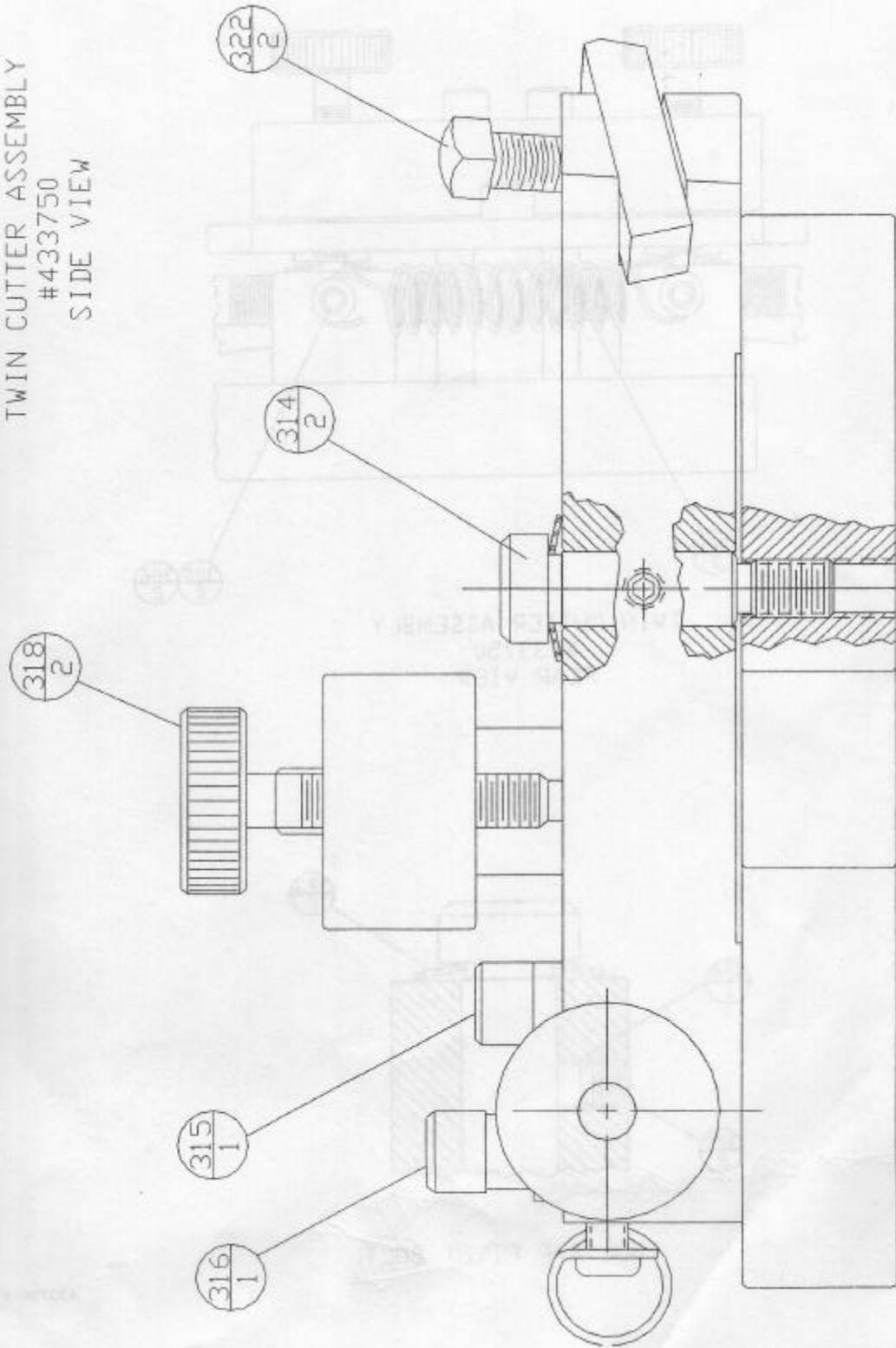

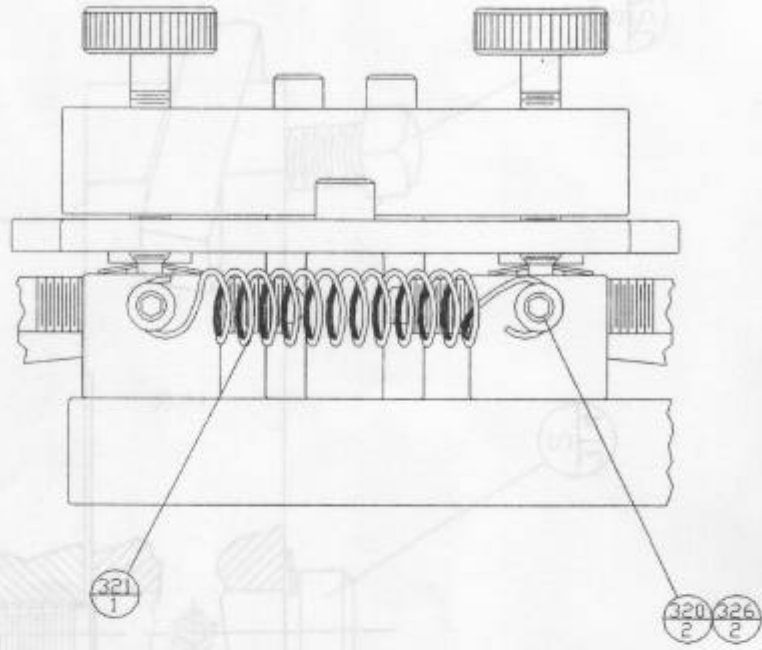

TWIN CUTTER ASSEMBLY
#433750
REAR VIEW

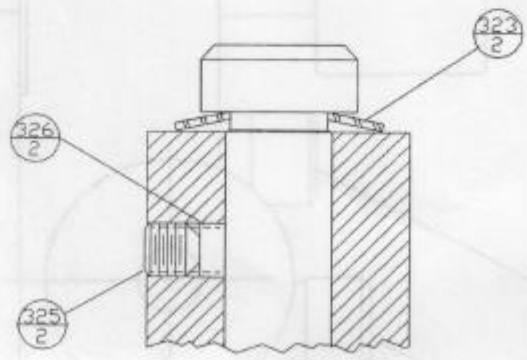

TOOL BAR PIVOT BOLT