

**DISC BRAKE LATHE
MODEL 8911**

OPERATIONS AND MAINTENANCE MANUAL

07/97 250
#435049



Accu Industries, Inc:
P.O. BOX 15540 / RICHMOND, VA 23227
11126 AIR PARK ROAD / ASHLAND, VA 23005
804-798-8922 FAX 804-798-6742

ACCU-TURN

**DISC BRAKE LATHE
MODEL 8911**

OPERATIONS AND MAINTENANCE MANUAL

TABLE OF CONTENTS

List of Standard Equipment	1
Brake Lathe Specifications	1
Acceptance From Carrier	2
Safety Information	2
Assembly of Lathe	7
Operation Procedures	
Inspection	8
Disc Rotors	8
Parts List	10
Diagrams	15

When ordering parts, please give the Serial # of your machine and the Date Purchased; this will help in expediting your order.

**FOR YOUR RECORDS AND INFORMATION:
MODEL 8911**

Date received: _____

Serial number: _____

07/97 250
#435049

STANDARD ACCESSORIES INCLUDED WITH THE 8911 DISC BRAKE LATHE

- 1 Draw Bar with Hex Nut and Washer
- Passenger Car & Light Truck Adapter Set
 - 2 Large Bell Clamps
 - 2 Small Bell Clamps
 - 3 Centering Cones for Floating Rotors & Drums
 - 3 Silencers
 - 5 Double Taper Radius Adapters
 - 1 Twin Cutter with Tool Holders, for Rotors
 - 1 Standard 1" Arbor
 - 1 Arbor Nut
 - 1 Arbor Spring
 - 1 1" Spacer
 - 1 Set of Alignment Washers
 - 3 Wrenches 1 1/2", 7/8", 3/8"

8911 DISC BRAKE LATHE SPECIFICATIONS

115 Volt	50/60Hertz	Phase 1	10.0 Amps
Rotor Capacity		4" to 24"
Maximum width of surface		4 1/2"
Maximum thickness		2 1/4"
Maximum Weight:			
On 1" Arbor		150 lbs.
On 1 7/8" Arbor		300 lbs.
Spindle Speed RPM		105
Feeds Per Spindle Revolution:			
Disc003
Motor		1 Horsepower
Weight		405 lbs. Net.
		466 lbs. Ship Wt.

ACCEPTANCE FROM TRANSPORTATION CARRIER

Carefully inspect all items received in this shipment. If there is damage or evidence of mishandling in transit, determine the extent of damage and notify the transit company as well as ACCU Industries, Inc. immediately. Although we are not responsible for damage incurred in transit, we will assist in the preparation and filing of claims.

SAFETY INFORMATION

This manual has been prepared for the operator and those responsible for the maintenance of the brake lathe. Its purpose, aside from proper maintenance and operations, is to promote safety through the use of accepted practice.

READ AND UNDERSTAND THE SAFETY AND OPERATING INSTRUCTIONS COMPLETELY BEFORE OPERATING THE MACHINE

In order to obtain maximum life expectancy and efficiency from your brake lathe, follow the operating instructions and maintenance manual carefully.

The specifications put forth in this manual were in effect at the time of publication. However, owing to ACCU Industries' policy of continuous improvement, changes to the specifications may be made at any time without obligation on the part of ACCU Industries, Inc.

Safety Instructions

1. Read, understand and follow the safety and operating instructions found in this manual. Know the limitations and hazards associated with operating the machine. A safety rules decal is installed on the machine to serve as a reminder of basic safety practice. It should be read before attempting to use the brake lathe.
2. Special Precautions: This ACCU-Turn brake lathe was designed to machine the portions of the brake drum, disc brake rotor and flywheel surfaces that come in contact with the friction material. When used according to the instructions herein, this lathe will perform satisfactorily within the workpiece size range designated for this model.

During the machining operation, the workpiece rotates. Be especially cautious of rotating wheel lugs, spokes and

cause a sharp edge to be generated, where a chamfer or radius previously existed. Use care in handling machined parts.

3. Securing the Machine: The model 8944 weighs approximately 470 pounds and must be bolted to an ACCU-TURN Heavy duty Floor Stand or a bench capable of supporting the machine, its accessories and workpiece.
4. Grounding the Machine: In the event of a malfunction or breakdown, grounding provides a path of least resistance for electric current to reduce the risk of electric shock. The lathe is equipped with an electric cord having an equipment-grounding conductor and a grounding plug. The plug must be plugged into a matching outlet that is properly installed and grounded in accordance with all local codes and ordinances.

Do not modify the plug provided. If the plug will not fit the outlet, have the proper outlet installed by a qualified electrician.

Improper connection of the equipment-grounding conductor can result in a risk of electric shock. The conductor with insulation having an outer surface that is green with or without yellow stripes is the equipment-grounding conductor. If repair or replacement of the electric cord or plug is necessary, do not connect the equipment-grounding conductor to a live terminal.

Check with a qualified electrician or service personal if the grounding instructions are not completely understood, or if in doubt as to whether the lathe is properly grounded.

Use only 3-wire extension cords that have 3-prong grounding plugs and 3-pole receptacles that accept the lathe's plug.

Repair or replace damaged or worn cord immediately.

This lathe is intended for use on a circuit that has an outlet that looks like the one illustrated in Sketch A in Figure 4.1. The tool has a grounding plug that looks like the plug illustrated in Sketch A in Figure 4.1. A temporary adapter, which looks like the adapter illustrated in Sketches B and C, may be used to connect this plug to a 2-pole receptacle as shown in Sketch B if a properly grounded outlet is not available. The temporary adapter should be used only until a properly grounded outlet can be installed by a qualified electrician. The green-colored rigid ear, lug, or other grounding means extending from the adapter must be connected to a permanent ground such as a properly grounded outlet box.

5. Use Proper Extension Cord: Make sure your extension cord is in good condition. When using an extension cord, be sure to use one heavy enough to carry the current the lathe will draw. An undersized cord will cause a drop in line voltage resulting in a loss of power and overheating. Table 5.1 shows the correct size to use depending on the cord length. If in doubt, use the next heavier gage. The smaller the gage number, the heavier the cord.
6. Eye Safety: Wear an approved safety face shield, goggles, or safety glasses. (Ordinary eyeglasses are not safety glasses and do not provide the degree of protection necessary.) If the operation or area is dusty a face or dust mask should be used.
7. Personal Protection: Before operating the machine, remove tie, rings, watches, and other jewelry, and roll up sleeves above the elbow. Remove all outer loose clothing and confine long hair. Protective type footwear must be worn. Hearing protectors must be used where noise exceeds the level of exposure allowed in Section 1910.95 of the OSHA Regulations.

DO NOT WEAR GLOVES

8. DO NOT OPERATE MACHINE WITHOUT ITS GUARD(S) IN PLACE AND IN WORKING ORDER.
9. Do Not Use Lathe in Dangerous Environment: Don't use the lathe in damp or wet locations, or expose the lathe to rain. Keep the work area well lighted.
10. Work Area: Keep the floor around the machine clean and free of foreign materials. ACCU Industries recommends the use of anti-skid floor strips where the operator normally stands, and that each machine has its own work area marked off. Make certain that the work area is well-lighted and ventilated. Provide for adequate work space around the machine. The work area should not be readily accessible to anyone except the operator.
11. Do Not Overreach: Maintain a balanced stance and keep your body under control at all times.
12. Hand Safety: Keep hands away from moving parts when the machine is under power. Never clear chips or debris when the machine is under power and never use your hands to clear the chips. Never use compressed air to clean machine; use only a soft bristle brush or vacuum cleaner.
13. Spindle Rotation: Rotate spindle by hand before applying on

power. Be sure that the rotation of the spindle is correct.

14. Machining Preparation: Tighten all locks before operating the lathe. Be sure workpiece is secured. Remove adjusting keys and wrenches. Be sure to check to see that all adjusting wrenches are removed from the lathe before turning the machine
15. Check Damaged Parts: Before further use of the lathe, a guard or other part that is damaged should be carefully checked to determine if it will operate properly and perform its intended function. Check for alignment of moving parts, binding of moving parts, breakage of parts, mounting, and any other conditions that may affect the lathe's operation. A guard or other part that is damaged should be properly repaired or replaced.
16. Maintain Tools with Care: Keep tools sharp and clean for best and safest performance. follow instructions for lubricating and changing accessories.
17. Avoid Accidental Starting: Make certain that the motor switch is in the "Off" position before connecting power to the machine.
18. Never Stand on Lathe: Serious injury could occur if the lathe is tipped or if the cutting tool is unintentionally contacted.
19. Machine Capacity: Do not attempt to use the machine for other than passenger car and light truck drums, discs and flywheels, or for operations for which the machine was not intended.
20. Careless Acts: GIVE THE WORK YOU ARE DOING YOUR UNDIVIDED ATTENTION.
21. Disconnect Electrical Power before performing any service, maintenance, or changing of accessories, adapters, or workpieces on machine.
22. Job Completion: If the operator leaves the machine area for any reason, the machine should be turned off, and the spindle brought to a complete stop before the operator departs. In addition, if the operation is complete, the operator should clean the machine and work area. NEVER CLEAN THE MACHINE WITH THE POWER ON.
23. Replacement Parts: Use only ACCU-TURN replacement parts and accessories, risk of injury may result if accessories other

than those recommended are used. USE OF PARTS OTHER THAN ACCU-TURN PARTS WILL VOID THE WARRANTY.

24. Misuse: Do not use the machine for other than its intended use. If used for other purposes, ACCU Industries Inc., disclaims any expressed or implied warranty, and holds itself harmless for any injury or loss that may result.

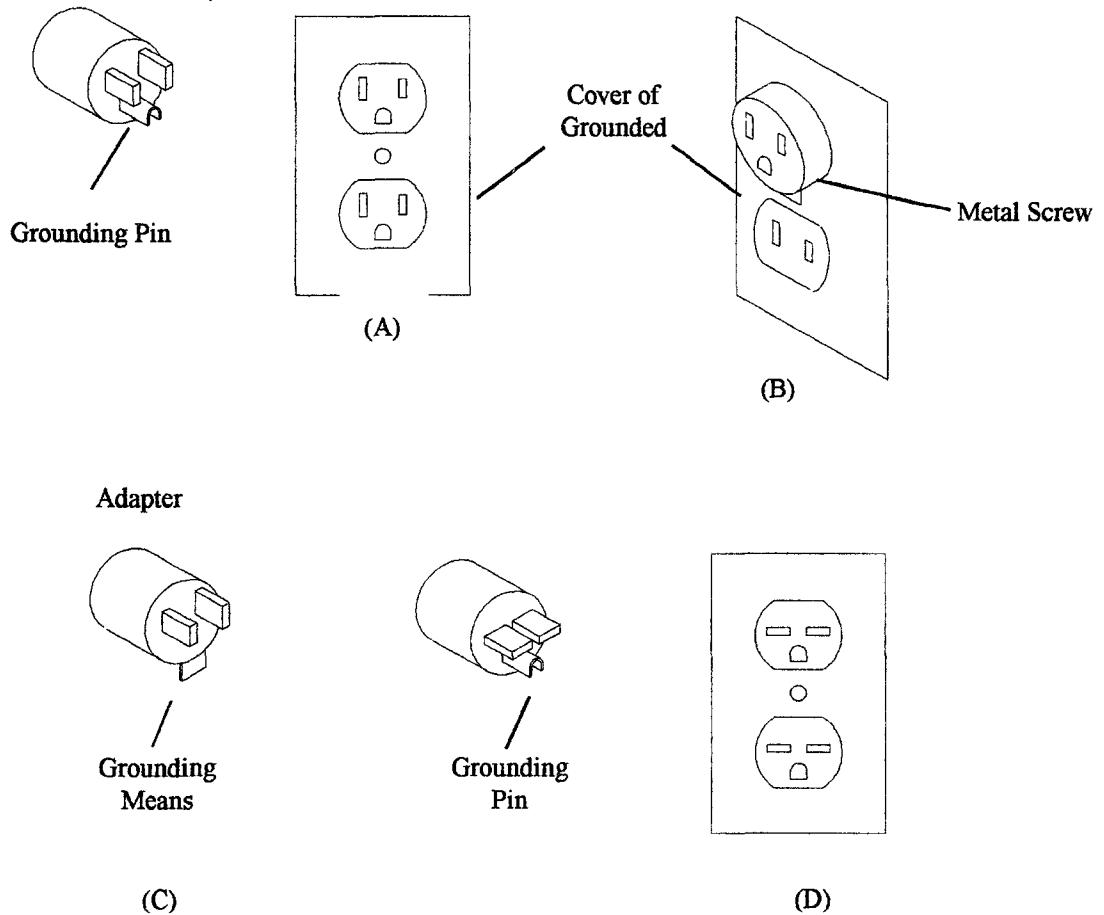

Fig. 4.1

Amper Rating	Volts	Total length of cord in feet			
	120 V	25 ft.	50 ft.	100 ft.	150 ft.
More Than	Not More Than	AWG			
12	16	14	12	Not Recommended	

Table 5.1

ASSEMBLY OF BRAKE LATHE

Setting Up Brake Lathe For Operation

All machine surfaces are covered with a protective coating before packaging. They must be thoroughly cleaned with solvent. The spindle, arbor taper and mounting surface on top of ways should also be cleaned.

Install the draw bar in the arbor, using the end with the longest threads, and screw in snugly. Insert the draw bar through the spindle, and align the match marks on the arbor and spindle. Install the washer and nut on the rear of the draw bar, and tighten until the spindle rotates. Mount the drum boring bar or rotor twin cutter on the machine; make sure all inserts, bolts, and set screws are tight.

Machine must be securely fastened to work bench surface before operating. Four mounting lugs on the base are provided for this purpose.

Lubrication

Lubricate ways by oiling felt wipers on the end of cross slide every week with SAE 10W oil or equivalent, and check gear box by removing vented plug on top rear of housing. Oil, level should be about 2 inches from the top. If needed, use MOBIL Synthetic Gear Oil - #411488 or equivalent. Capacity is one quart. DO NOT OVER-FILL.

Electrical Information

Standard motors on this machine are wired to 115 volt, 50/60 cycle, single phase. Check electrical input plate on rear of machine. The Off-On switch is located to the right end of the main housing. Never operate machine unless power supply agrees with electrical plate rating and machine is properly grounded.

ACCU-TURN 8911 DISC BRAKE LATHE OPERATION PROCEDURES

Inspection of Disc Rotors Before Machining

IMPORTANT: The maximum amount of metal removed from the finished workpiece should never exceed the manufacturer's specifications. It is dangerous to operate a vehicle with a rotor which has had more material removed than is allowed. Proper operation can not be established if these specifications have been exceeded. ACCU Industries, recommends that each workpiece be check for size before mounting on the machine.

Mounting Hubless Disc Rotors

1. Use a centering cone to fit the center of the large bore of the rotor. Bore must be clean and free of burrs.
2. Select bell clamps & slide one on the arbor.
3. Next slide spring and proper centering cone against bell clamp.
4. Mount the rotor so that the dished side is to the right & position the rotor on the centering cone.
5. Slide the other bell clamp on the arbor.
6. Mount necessary spacers (double tapered radius adapters may be used as spacers), alignment washers and hex nut and tighten securely.

Mounting Hubbed Rotors.

1. Select double tapered radius adapter that will fit the bearing races on either side of the disc rotor. Slide the largest adapter against the rear of the arbor.
2. Slide rotor onto the arbor making certain that the double tapered radius adapter is seated well into the bearing race.
3. Add the other double tapered radius adapter and then the necessary spacers, alignment washers and the hex nut, until both adapters are firmly seated and the assembly is tightly locked.

NOTE: On certain hubbed rotors, it may be necessary to use additional adapters or cones to properly secure the rotor on the arbor.

4. Install the silencer around the outer edge of the rotor. Make sure that the alignment washers are next to the hex nut, with concave to convex.

Machining Hubless and Hubbed Rotors.

1. The twin cutter must be positioned in proper alignment with the rotor. Center the disc rotor between the two tool bar holders. The tool bars are fed by calibrated knobs at either sides of the bars.
2. Set the tool bars for depth of cut by loosening the locking screw on top of the tool bars so that the bars will move freely.
3. Adjust cutter bars to remove only the minimum amount required to finish the rotor in one cut. **DO NOT MACHINE A ROTOR TO LESS THAN MANUFACTURER'S SPECIFICATIONS.**
4. Locate the deepest score and turn the rotor micrometer knobs until the tool bit bottoms out at the deepest point of the score; zero the scale and back out the tool bit.
5. Advance the twin cutter by handwheel until the tool bits have cleared the inner edge of the rotor face. Adjust the micrometer knobs for approximately .005 more than the first reading. This will ensure clearing the rotor in one cut.
6. Tighten locking screw until it is snug. **IT IS NOT NECESSARY TO TIGHTEN THIS SCREW DOWN EXCESSIVELY.**

The replaceable carbide inserts have three cutting surfaces. When sufficient wear causes an inferior finish, rotate the carbide insert to a new tip. There is precision relief below the cutting edge: **DO NOT TURN THESE INSERTS OVER.**

**FOR INFORMATION ON SPECIAL APPLICATIONS,
CONTACT YOUR ACCU-TURN DISTRIBUTOR.**

Sharp Tools are Vital to Satisfactory Operation

When ordering supplies or replacement parts for this machine, always give the serial # of the machine. Use only ACCU-Turn parts.

**8911 DISC BRAKE LATHE
PARTS LIST**

ITEM #	PART #	QTY REQ'D	DESCRIPTION
1	434013	1	HOUSING
2	434014	1	COVER, HOUSING
3	434420	1	GASKET .015
4	420772	4	SCREW
6	433605	1	SPINDLE
7	433618	1	BEARING, CONE
8	433619	1	BEARING, CUP
9	433616	1	BEARING, CONE
10	433772	1	BEARING, CUP
11	433622	1	SEAL
12	431146	1	SEAL
13	433620	1	SEAL
14	408129	1	SEAL
15	433611	1	SHIM
16	433612	1	SHIM
17	411342	1	KEY
19	433974	1	SCREW, SET
21	408365	1	LOCK WASHER
22	408364	1	LOCK NUT
23	433607	1	SHAFT, WORM
24	433614	2	BEARING, CONE
25	433615	2	BEARING, CUP
26	433608	1	CARRIER, BRG.
27	421643	1	GASKETS
28	411389	4	SCREW
29	420149	1	SEAL
30	434368	1	DOVE TAIL, CTR
31	433634	4	SCREW
32	433790	2	WEAR STRIP ASSY.
33	433635	1	WAY WIPER ASSY. TOP
34	433638	10	SCREW
35	434365	1	DOVE TAIL, RISER BLOCK
36	433627	1	DOVE TAIL, TOP
37	433630	4	SCREW, SET
38	413294	4	WASHER
39	413291	4	NUT, HEX
40	433639	1	SCREW, TURN

ITEM #	PART #	QTY REQ'D	DESCRIPTION
42	433156	1	SCREW, ROTOR FEED ASSY
44	435536	2	PIN
15	435586	2	BOLT WASHER HEAD
47	433623	1	BEARING, BALL
48	433907	1	HOUSING, FEEDBOX
50	433647	1	NUT, ROTOR FEED
51	411378	2	SCREW
52	417258	1	SCREW
53	433641	1	MOTOR 1/60, 6 RPM
54	434081	4	SCREW
55	434384	1	ASSY., SHIFTING YOKE
56	434016	1	COLLAR
57	421431	1	KEY
58	434439	1	DRIVE ADAPTER
59	433974	1	SCREW, SET
60	433653	1	PINION, SPUR 55 TEETH
61	433655	1	SPRING, CONICAL
62	433654	1	WASHER
63	421077	1	GEAR, SPUR 70 TEETH
65	433649	1	SWITCH, LIMIT
68	433908	1	COVER, FEEDBOX HOUSING
69	434017	1	SNAP-IN NYLINER
70	433909	1	HANDLE, SHIFTER
71	433974	4	SCREW, SET
72	1A2169	1	SPRING
73	408373	1	BALL
74	433667	1	GUARD, RTR WAY MOTOR
76	433638	2	SCREW
77	433735	1	TELESCOPING WAY ASSY.
78	433648	6	SCREW
79	433682	2	SPACER
80	433688	2	SCREW
81	433687	2	SCREW
83A	434362	1	HANDWHEEL
83C	433666	1	HANDLE, REVOLVING
83D	433781	1	DECAL, CALIB. 0-95
83E	408409	1	SCREW
83F	433974	1	SCREW, SET
84	433729	1	BASE, MOTOR ASSY.
85	433626	1	SHAFT, MOT. BASE PIVOT
86	434228	2	SCREW, SET
87	433670	1	MOTOR 115/230 VOLT 1 PHASE, 1 H.P.

ITEM #	PART #	QTY REQ'D	DESCRIPTION
88	434574	4	WASHER
89	434575	4	SCREW
90	433671	1	SHEAVE
91	433672	1	SHEAVE
92	433673	1	V-BELT
93	433675	1	GUARD, BELT
94	433638	2	SCREW
95	433685	1	LAMP
96	433674	1	FITTING, RELIEF
97	413281	1	PLUG, PIPE
98	411488	32 OZ.	OIL, MOBILE SYNTHETIC GEAR OIL, #SHC-634
99	433830	TRACE	STOR-AND-LUBE
100	411478	1 OZ.	GREASE #2
101	433727	1	POWER CORD ASSY.
102	433726	1	MOTOR CORD ASSY.
103	433698	1	WIRE, ELECTRICAL
108	433719	5	CLAMP, CABLE 2 SCREW
109	433721	1	CONDUIT, FLEXIBLE
110	434133	5	CONNECTOR, CRIMP-ON
111/112	434132	2	CONNECTOR, CRIMP-ON
113	433818	1	SCREW
114	434402	1	SCREW
115	434359	1	SWITCH, TOGGLE
116	434360	1	PLATE, INDICAT. ON/OFF
117	433732	1	LABEL, WARNING
118	433733	1	LABEL, CAUTION
119	434603	1	NAMEPLATE, SERIAL #
121	433633	1	BOLT T SLOT
123	434280	1	WASHER
124	433617	1	NUT, HEAVY HEX
129	433717	3	CARBIDE BIT & SCREW
130	434009	1	CAP PLUG
131	433974	4	SCREW, SET
133	434378	1	PATENT NUMBER PLATE
132	406680	3	SHIM
136	434519	1	STICKER, TIMKEN BRG.
137	434700	4	NUT, HEX
138	433994	4 OZ.	GREASE, EXXON LIDOK 000
139	434800	1	PLUG, PUSH IN
150	434815	2	SCREW
151	434401	2	SCREW
152	415848	1	CAP THREAD
153	434612	1	PLUG, KNOCK OUT
	436259	1	WAY WIPER KIT

TWIN CUTTER ASSEMBLY #433750

ITEM #	PART #	QTY REQ'D	DESCRIPTION
300	433752	1	BASE, ROTOR-TRUER
301	433753	1	BASE, CUTTER TENSION BAR
302	433754	1	BASE, ROTOR-TRUER POINTER
303	433755	1	TOOL HOLDER, R.H.
304	433757	1	CUTTER TENSION BAR
306	433759	1	ADJUSTING WHEEL, ROTOTRUER
307B	436272	1	EXTENDED KNOB
308	433760	2	ADJUSTMENT SCREW
309	433761	2	CALIB. WHEEL R.T.
311	433764	1	TOOL BIT HOLDER L.H.
314	433765	2	SCREW, SHOULDER
315	420212	1	SCREW
316	420211	1	SCREW
317	433766	2	SCREW
318	433767	2	SCREW, THUMB
319	433768	2	WASHER, WAVE
320	420772	2	SCREW, DRIVE
321	433770	1	SPRING, ROTOR-TRUER
322	433771	2	SCREW, SET
323	434738	2	SPRING, BELVILLE
325	433773	4	BALL, NYLON

STANDARD ACCESSORIES

ITEM #	PART #	QTY REQ'D	DESCRIPTION
200	433702	1	BAR, DRAW
201	4B4280	1	WASHER
202	433617	1	NUT, HEAVY HEX
203	433703	2	PLATE, FACE 1
204	433704	2	PLATE, FACE 2
205	433705	1	CENTERING CONE, DRUM # 1
206	433706	1	CENTERING CONE, DRUM # 2
207	433707	1	CENTERING CONE, DRUM # 3
208	433708	1	ADAPTER # 1
209	433710	1	ADAPTER # 3
211	433711	1	ADAPTER # 4
212	433617	1	NUT, HEAVY, HEX.
213	433712	1	SPACER, ARBOR
214	433715	1	WASHER, ASSEMBLY SELF ALIGNING
215	433713	1	NUT, HEX
216	433774	1	SPACER
217	433716	1	SPRING, ARBOR
219	433785	1	SILENCER, LG. VENTED ROTOR
220	433789	1	SILENCER, SMALL NON- VENTED ROTOR
221	436410	1	WRENCH 1 1/2 BOX END
222	433963	1	ADAPTER # 1-A
223	434558	1	WRENCH, 3/8" SOCKET
224	434559	1	WRENCH, 7/8" OPEN END
	433750	1	RT GROUP W/TOOL HOLDERS

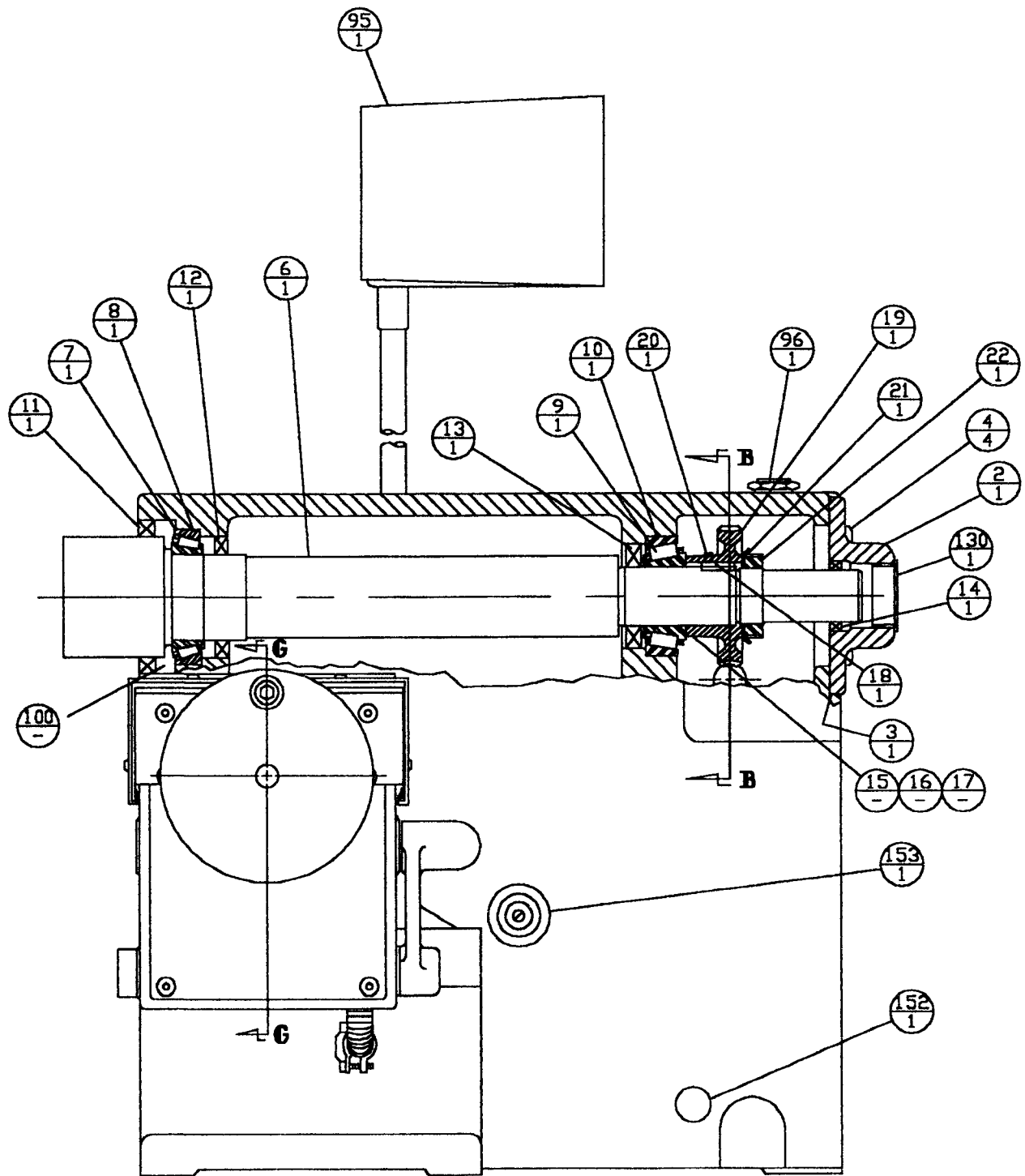

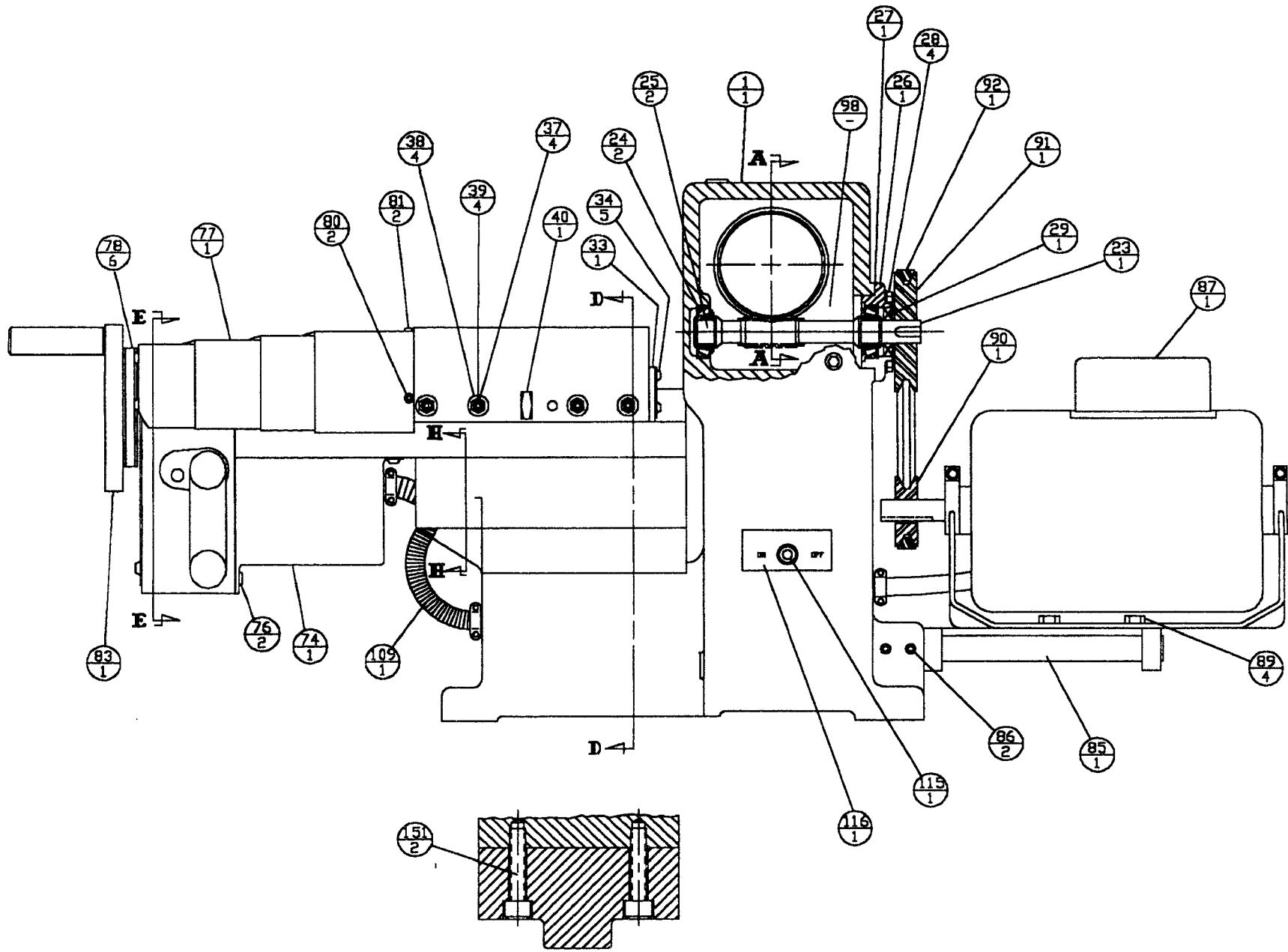

SECTION H H

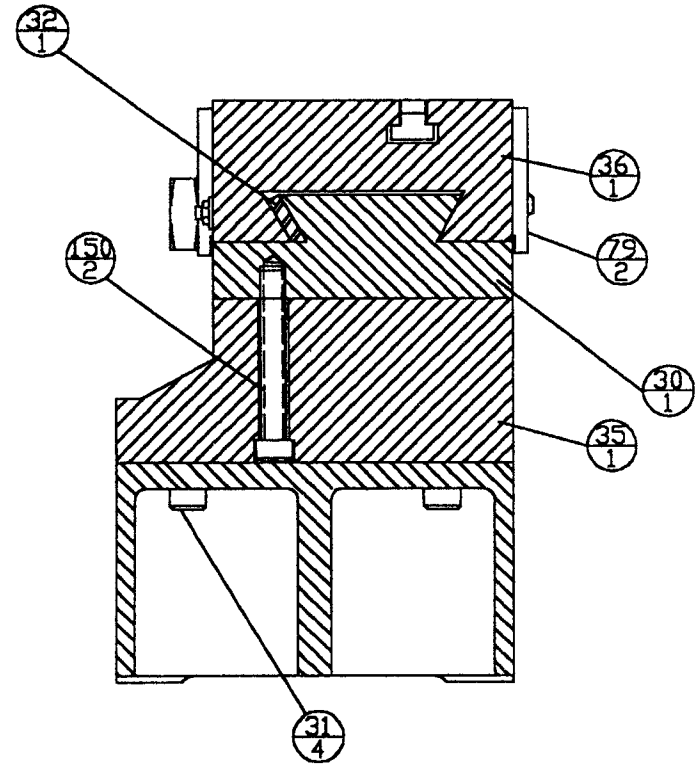
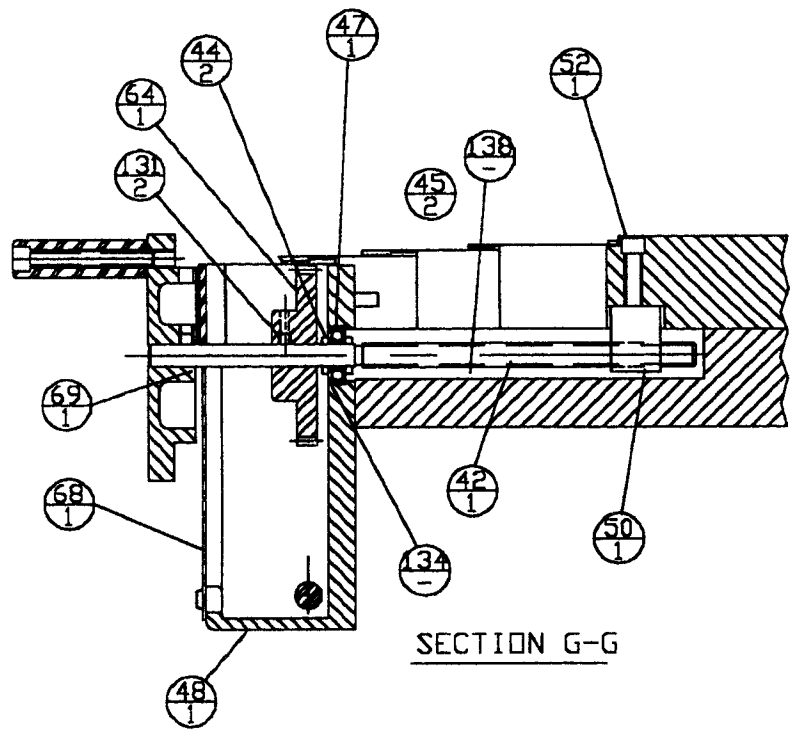

SECTION D-D

